

ACTIVE SWITCH

PLANTS FOR USE OF RAINWATER



TECHNICAL DATA

Max capacity (lt/min-m3/h): 80-4.8
Max head: 42.2 m
Max. Liquid temperature: FROM +5°C TO +35°C
Max. system pressure: Max 6 bar
Max. mains pressure: Max 4 bar
Minimum mains flow rate: Min 10 lt/min
Maximum height of the highest point of use: 15 m
Power supply: Volt 220-240 Hz50
Maximum power absorbed: 880 W
Protection rating: IP 20
Ambient temperature: Min +5 °C Max +40 °C
Tank materials PE
Mains inlet pipe dimensions: 3/4"
Discharge pipe dimensions: 1"
Suction pipe dimensions: 1"
Overflow pipe dimensions: DN 50
Max Altitude: 1000 metres
Water type: ph 4-9
ON/OFF float version: ON/OFF float with 20 metre cable
Dry weight in Kg: 15
Operational weight in Kg: 30

APPLICATIONS

The ACTIVE SWITCH unit is used for rainwater management. The unit detects a lack of water in the collection system, whether from rainwater or the mains and makes corrections to ensure proper operation of the plant (that is, it does not ever leave the connected utilities dry). Generally, this system is reserved for irrigation, clothes washing, WC flushing and floor cleaning applications. The primary purpose of the ACTIVE SWITCH system is to give use of the rainwater priority over the use of the mains water. When there is not enough rainwater in the collection tank, the control unit switches over to the mains, ensuring that the connected use points are supplied (PLEASE, NOTE the water supplied by this system is not potable). The connection between the rainwater collection tank and the mains water collection tank in this system is selected by way of a three-way valve installed on the suction side of the pump. Pump operation is precisely that of a "start-stop" system with pressure and flow control. When the pressure drops below a certain threshold level, the pump starts up. Upon closing the tap, the pump stops. If the water runs out, the pump stops and signals a fault on the pump control panel. After a set time, the pump starts back up again automatically. If all the functions' parameters have returned to normal, then the system runs normally. The system is also equipped with a special anti-odour anti-emptying siphon.

TECHNICAL SPECIFICATIONS

The system comprises a polyethylene (PE) console and an EURO INOX 30/50 M IE2 electric centrifugal pump. The kit also includes a wall mount bracket and a water level sensor with 20 metres of cable.

MATERIALS

N°	PARTS	MATERIALS
1	PRESSURISED WATER OUTLET	PA 6.6 + 30% F.V.
2	RAINWATER SUCTION	STEEL HOSE
3	3-WAY VALVE	VALVE BODY: BRASS RETURN SPRINGS: STEEL MOTOR COVER: SELF-EXTINGUISHING ABS
4	RAINWATER COLLECTION TANK	PE
5	OVERFLOW DRAIN SIPHON	PP HOMOPOLYMER
6	PUMP	SEE EUROINOX
7	MAINS WATER INLET	STEEL HOSE
8	PUMP LOAD PLUG	PPE / O-R IN NBR
9	PIPE UNION	3PCS MF 1"

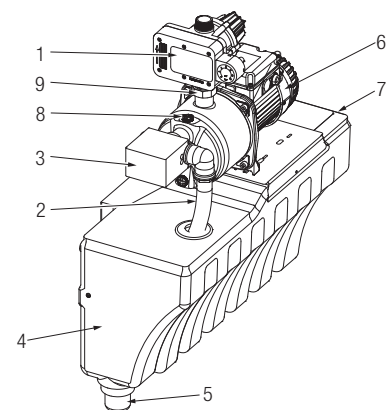

INSTALLATION DIAGRAM

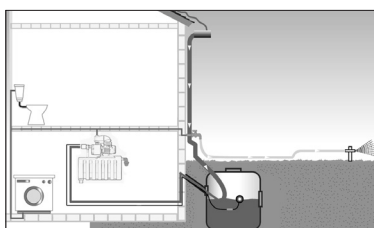

CONTROL PANEL

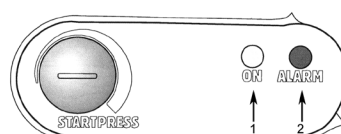

ACTIVE SWITCH

PLANTS FOR USE OF RAINWATER

PERFORMANCE RANGE

The performance curves are based on kinematic viscosity values = 1 mm²/s and density equivalent to 1000 kg/m³. Curve tolerance according to ISO 9906.

GRAPHIC SELECTION TABLE

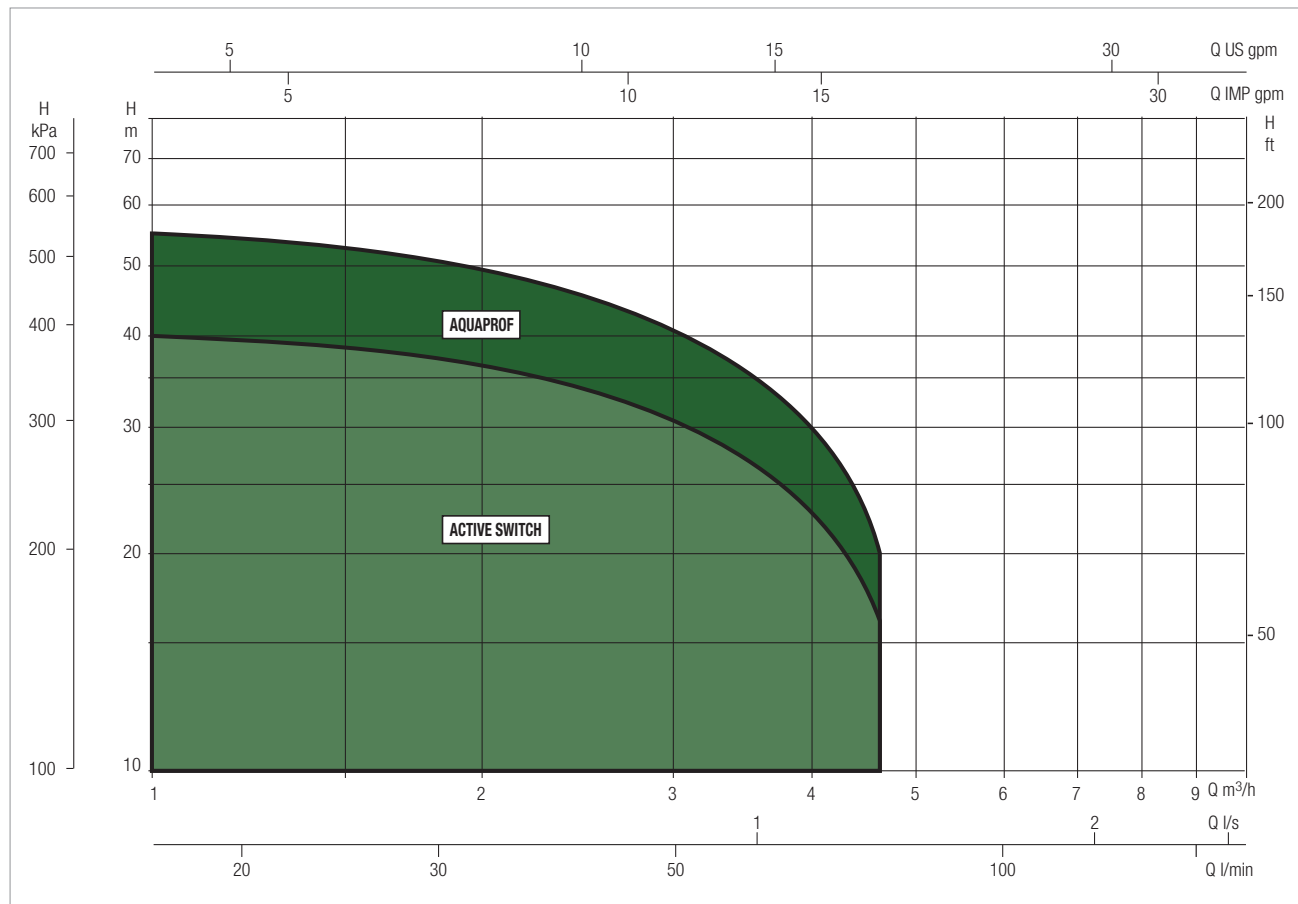

ACTIVE SWITCH SELECTION TABLE

MODEL	Q=m ³ /h	0	0,6	1,2	1,8	2,4	3,0	3,6	4,2	4,8
	Q=l/min	0	10	20	30	40	50	60	70	80
ACTIVE SWITCH 30/50 M	H (m)	42,2	40,2	38,2	36,2	33,8	30	24,8	19,5	14

ACTIVE SWITCH - PLANTS FOR USE OF RAINWATER

Liquid temperature range pumped: from +5 °C to +35 °C - Maximum ambient temperature: +40°C

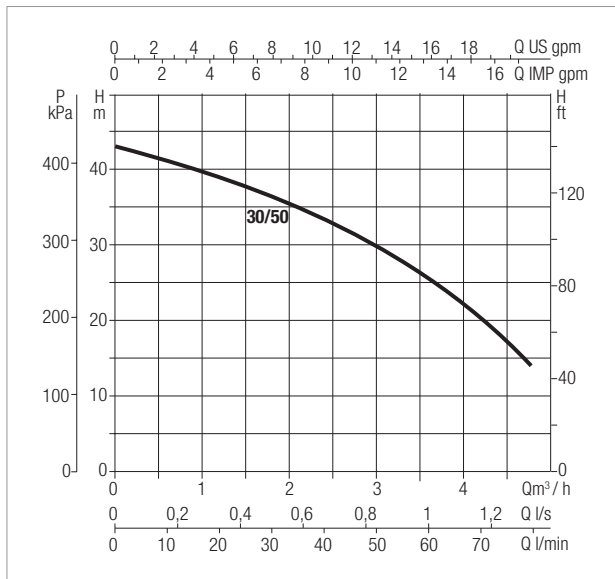
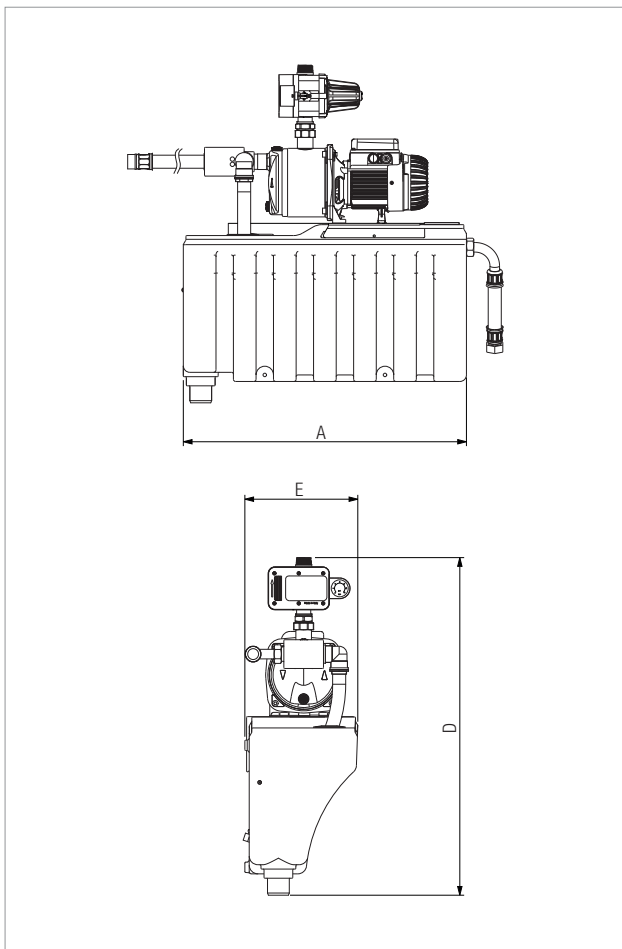

The performance curves are based on the kinematic viscosity values = 1 mm²/s and density equivalent to 1000 kg/m³. Curve tolerance according to ISO 9906.

MODEL	ELECTRICAL DATA						
	POWER SUPPLY 50 Hz	P1 MAX kW	P2 NOMINAL		In A	CAPACITOR	
			kW	HP		µF	Vc
ACTIVE SWITCH 30/50 M	1x220-240 V ~	0,903	0,55	0,75	3,9	12,5	450

MODEL	A	D	E	DNA GAS	DNM GAS	WEIGHT Kg	Q.TY X PALLET
ACTIVE SWITCH 30/50 M	650	775	259	1"	1"	18	4