

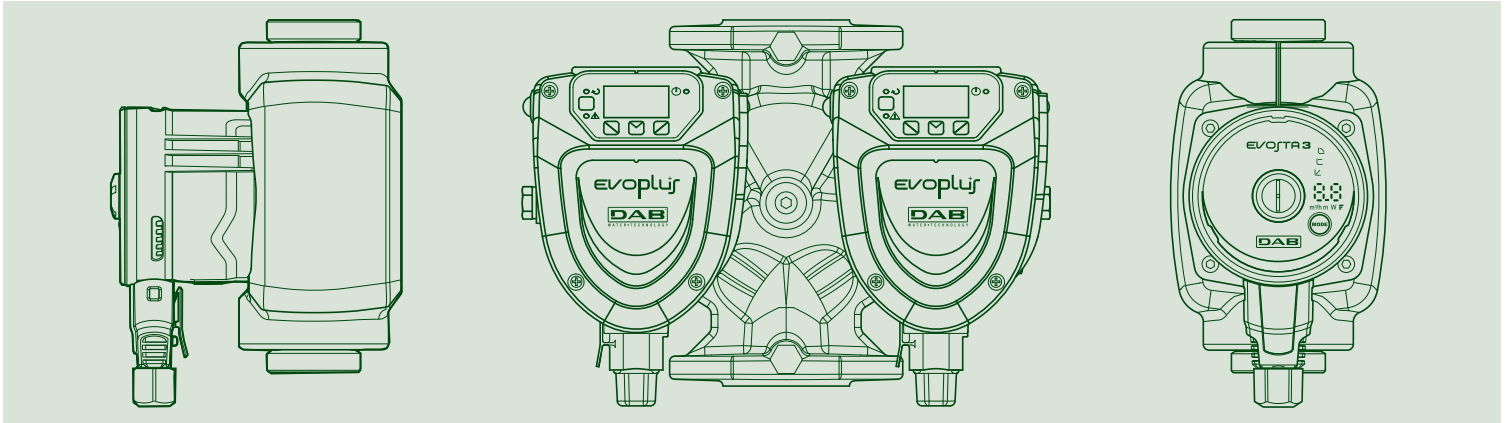

CIRCULATORS



TECHNICAL CATALOGUE



THE INTERNATIONAL CERTIFICATION NETWORK

CERTIFICATE

CISQ/IMQ has issued an IQNet recognized certificate that the organization:

DWT HOLDING SPA
 VIA MARCO POLO 14 - 35035 MESTRINO (PD)
 BRENDOLA (VI) - CASTELLO DI GODEGO (TV) - BIENTINA (PI) -
 VAL LIONA (VI) - PRC CHINA - HUNGARY

has implemented and maintains a

Quality Management System

for the following scope:

Design, production, sale and assistance of components and electronic controls for pumps, electropumps and pump sets for cold and hot water for civil, industrial and agricultural use

Further clarifications regarding the applicability of ISO 9001:2015 requirements may be obtained by consulting the organization:

which fulfills the requirements of the following standard:

ISO 9001:2015

Issued on: **2018 - 05 - 21**
 Expires on: **2021 - 05 - 27**

This attestation is directly linked to the IQNet Partner's original certificate and shall not be used as a stand-alone document

Registration Number: IT - 824



Alex Stoichitov
President of IQNET



Ing. Claudio Provetti
President of CISQ

IQNet Partners:
 AENOR Spain AFNOR Certification France APCER Portugal CCC China CISQ Italy
 CQC China CQM China CQS Czech Republic Cx Cert Croatia DQS Holding GmbH Germany FCAN Brazil
 FONDONORMA Honduras ICONTEC Colombia Intertek Singapore Oly Finland INTECO Costa Rica
 IRAM Argentina JQA Japan KIPK Korea NUREC Greece MSZT Hungary Nemko AS Norway NSAI Ireland
 NYCE-SICE Mexico PCBC Poland Quality Austria Germany SR Russia SRI Israel SQI Slovenia
 SIRIM QAS International Malaysia SQS Switzerland SRAC Romania TEST St Petersburg Russia TSE Turkey YUQS Serbia
 IQNet is represented in the USA by: AFNOR Certification, CISQ, DQS Holding GmbH and NSAI Inc.

* The list of IQNet partners is valid at the time of issue of this certificate. Updated information is available under www.iqnet-certification.com



Al. 19/1
Ann. 1 of 1

www.imq.it

ALLEGATO CERTIFICATO n. **9101.COGE**
 ANNEX CERTIFICATE

(*) Unità Operative:
 (*) Operative Units:

DAB PUMPS SPA
 VIA BONANNO PISANO 1 - 55031 BIENTINA (PI)

DAB PUMPS SPA
 VIA DEL LAVORO 3 - 35040 VAL LIONA (VI)

DAB PUMPS QINGDAO CO. LTD
 40 KAITUO ROAD, QINGDAO DEVELOPMENT ZONE - SHANGDONG PROVINCE, PRC CHINA

DAB PUMPS HUNGARY KFT
 BUDA ERNO H - 8800 NAGYKANISZA HUNGARY

DATE	PRIMA CERTIFICAZIONE FIRST CERTIFICATION	EMISSIONE CORRENTE CURRENT ISSUE	SCADENZA EXPIRY
	1995-07-17	2018-05-21	2021-05-27



IMQ S.p.A. - VIA GURTIANO, 43 - 20138 MILANO ITALY
 Management Systems Division - Pavia Onigo



SGQ N° 005 A

IAF: 18, 19, 29



www.imq.com

www.cisq.com



CERTIFICATO N. **9101.COGE**
 CERTIFICATE N. **9101.COGE**

SI CERTIFICA CHE IL SISTEMA QUALITÀ DI
 WE HEREBY CERTIFY THAT THE QUALITY SYSTEM OPERATED BY

DWT HOLDING SPA
 VIA MARCO POLO 14 - 35035 MESTRINO (PD)

UNITÀ OPERATIVE / OPERATIVE UNITS

DAB PUMPS SPA
 VIA MARCO POLO 14 - 35035 MESTRINO (PD)
DAB PUMPS SPA
 VIA EINAUDI 2 - 35040 BRENDOLA (VI)
DAB PUMPS SPA
 VIA E. FERMI 6-8-10 - 31030 CASTELLO DI GODEGO (TV)

Vedere gli Allegati per le altre Unità Operative (n° 1 pagina)
 View the Annexes for the other Operative Units (n° 1 page)

E' CONFORME ALLA NORMA / IS IN COMPLIANCE WITH THE STANDARD
ISO 9001:2015

PER LE SEGUENTI ATTIVITÀ / FOR THE FOLLOWING ACTIVITIES

Progettazione, produzione, commercializzazione e assistenza di componenti e controlli elettronici per pompe, elettropompe e gruppi di pompaggio per acqua fredda e calda ad uso civile, industriale ed agricolo
 Design, production, sale and assistance of components and electronic controls for pumps, electropumps and pump sets for cold and hot water for civil, industrial and agricultural use

IL PRESENTE CERTIFICATO E' SOGGETTO AL RISPETTO DEL
 REGOLAMENTO PER LA CERTIFICAZIONE DEI SISTEMI DI GESTIONE
 THE USE AND THE VALIDITY OF THE CERTIFICATE SHALL SATISFY THE
 REQUIREMENTS OF THE RULES FOR CERTIFICATION OF MANAGEMENT SYSTEMS

DATE	PRIMA CERTIFICAZIONE FIRST CERTIFICATION	EMISSIONE CORRENTE CURRENT ISSUE	SCADENZA EXPIRY
	1995-07-17	2018-05-21	2021-05-27



IMQ S.p.A. - VIA GURTIANO, 43 - 20138 MILANO ITALY
 Management Systems Division - Pavia Onigo



SGQ N° 005 A

IAF: 18, 19, 29



www.imq.com

www.cisq.com

CONTENTS

WET ROTOR ELECTRONIC CIRCULATORS



EVOSTA 2



PAGE 3



EVOPLUS SMALL



PAGE 25



EVOSTA 3



PAGE 6



EVOPLUS SMALL SAN

PAGE 25



EVOSTA 2 SOL



PAGE 11



EVOPLUS



PAGE 57



EVOSTA 2 SAN V/R

PAGE 19



EVOPLUS SAN

PAGE 57



EVOSTA 2 SAN

PAGE 21

WET ROTOR CIRCULATORS



VA



PAGE 110



BPH / BMH / DPH / DMH



PAGE 142



A / B / D



PAGE 122



VS

PAGE 171

ACCESSORIES

TECHNICAL APPENDIX



PAGE 175

PAGE 183



TECHNICAL DATA

Operating range: 0,4-3,6 m³/h with head up to 6,9 metres.

Pumped liquid temperature range: from -10 °C to +110°C

Working pressure: 10 bar (1000 kPa)

Protection class: IPX5

Insulation class: F

Installation: with horizontal motor axis

Standard power input: single-phase 1x230 V~ 50/60 Hz

Pumped liquid Clean, free of solids and mineral oils, non-viscous, chemically neutral, with properties similar to water (glycol max 30%).

APPLICATIONS

Low energy consumption electronic pump for water circulation in all types of domestic heating and cooling systems.

ADVANTAGES

The new range of **EVOSTA 2** circulators by DAB combines the strength of a mechanical circulator with the benefits of the electronic circulator. Thanks to the permanent magnet synchronous motor, the frequency converter and the energy efficiency of $EEL \leq 0.18$, as well as the protection class IPX5 and the integrated bleeding plug, the **EVOSTA 2** family ranks as one of the best products in the category in terms of performance and reliability. The range of **EVOSTA 2** circulators is the perfect replacement for old three-speed circulators due to its compact size and all-round performance. The product is also extremely user-friendly, with a single button for sequential setting and direct access to the motor shaft for unlocking it when necessary.

CONSTRUCTION FEATURES

Cast iron pump body with cathaphoresis paint coating and wet rotor motor. Steel motor casing, technopolymer impeller. Ceramic motor shaft on ceramic bushings lubricated by the pumped liquid. Stainless steel rotor liner, stator liner and closing flange. Graphite thrust ring. EPDM seal ring and brass bleeding plug.

Thanks to the internal protection of the motor, the pump does not require any overload protection.

CONTROL PANEL

The settings of the **EVOSTA 2**, **EVOSTA 3** circulators can be modified in the control panel on the fascia of the pump device. The pumps have nine settings that can be selected scrolling the **MODE** button. Three LED lights on the fascia show the current setting.

EVOSTA 3 circulator has a display showing the following data:

- Head of the selected curve
- Instantaneous power consumption in Watts.
- Instantaneous head in m
- Instantaneous flow rate in m³/h

EVOSTA 2

WET ROTOR ELECTRONIC CIRCULATORS

MATERIALS

N.	PARTS	MATERIALS
1	ROTOR CAN FLANGE	AISI 316
2	IMPELLER	ULTRASON
3	SHAFT	ALLUMINA
4	ROTOR	Fe
5	BEARING HOUSING	BRASS
6	BEARING	ALLUMINA
7	AXIAL BEARING	GRAPHITE
8	AXIAL HOUSING	EPDM
9	PLUG	BRASS
10	O-RING	EPDM
11	STATOR HOUSING	AISI 304
12	ENCLOSURE SHELL	POLYCARBONATE
13	ENCLOSURE	POLYCARBONATE
14	ROTOR SLEEVE	AISI 304
15	SEAL	EPDM
16	PUMP HOUSING	CAST IRON
17	NECK RING	AISI 304
18	CONNECTOR	POLYCARBONATE

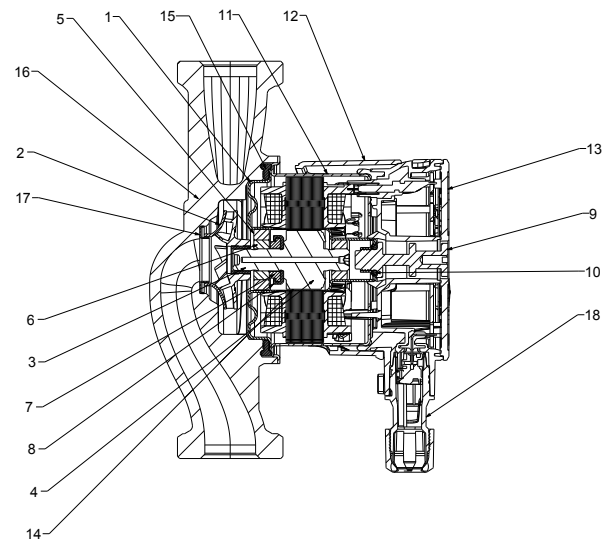

REGULATION MODE

PROPORTIONAL PRESSURE REGULATION MODE

PP1

PP2

PP3

CONSTANT PRESSURE REGULATION MODE

CP1

CP2

CP3

CONSTANT PRESSURE REGULATION

I

II

III

Model Number (example)

EVOSTA 40/70 130 X

Threaded connections electronic circulator _____

Maximum head range (dm) _____

Centre distance (mm) _____

Standard (no ref.) = 1" ½ threaded connections

½" = 1" threaded connections

X = 2" threaded connections

EVOSTA 2 - WET ROTOR ELECTRONIC CIRCULATORS

Pumped liquid temperature range: from -10 °C to +110 °C - Maximum operating pressure: 10 bar (1000 kPa)

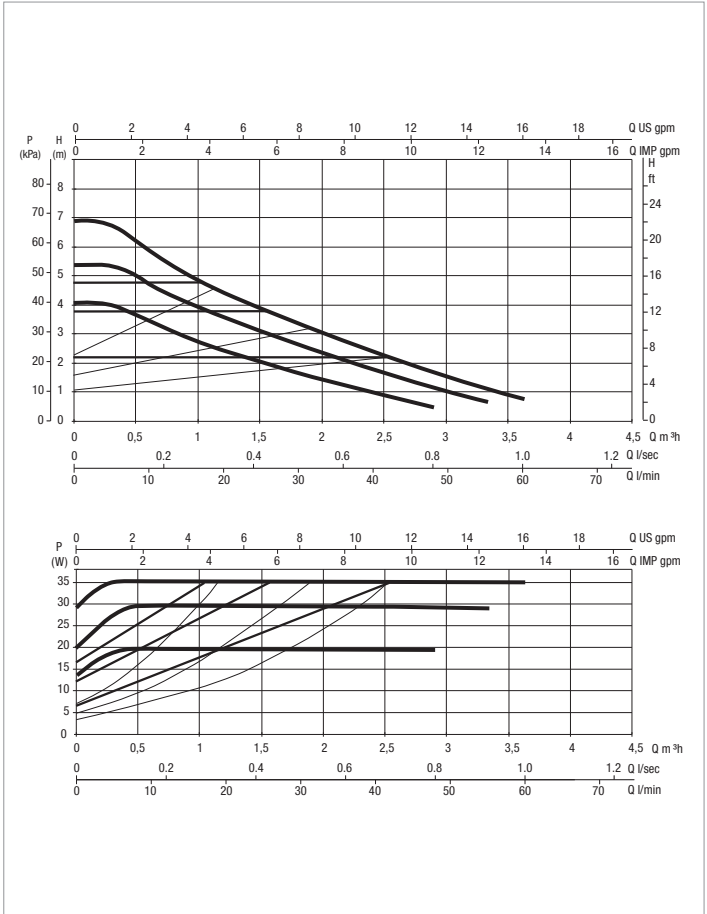
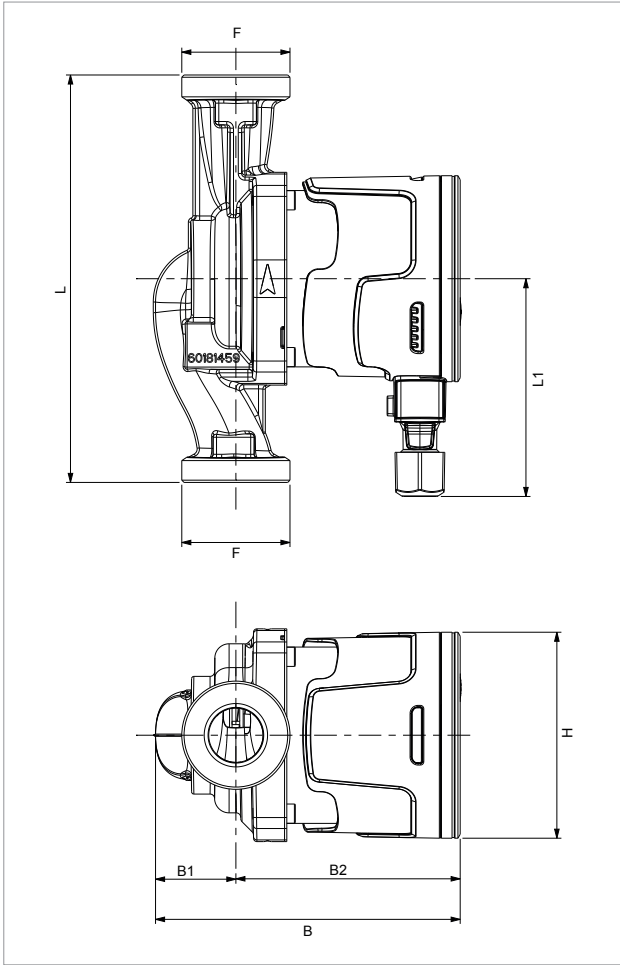

The performance curves are based on kinematic viscosity values = 1 mm²/s and density equal to 1000 kg/m³. Curve tolerance according to ISO 9906.

MODEL	Q=m³h	0,0	0,3	0,6	0,9	1,8	2,4	3,0	3,6
	Q=l/min	0	5	10	15	30	40	50	60
EVOSTA 2 40-70/130 (1")	H (m)	6,9	6,9	5,8	5,1	3,4	2,4	1,6	0,8
EVOSTA 2 40-70/130 (1/2")		6,9	6,9	5,8	5,1	3,4	2,4	1,6	0,8
EVOSTA 2 40-70/180 (1")		6,9	6,9	5,8	5,1	3,4	2,4	1,6	0,8
EVOSTA 2 40-70/180X (1"1/4)		6,9	6,9	5,8	5,1	3,4	2,4	1,6	0,8

MODEL	CENTRE DISTANCE mm	PUMP CONNECTIONS	POWER INPUT 50 Hz	P1 MAX W	In A	EEI *	MINIMUM SUCTION PRESSURE	
							t°	90°
EVOSTA 2 40-70/130 (1")	130	DN25 THREADED (G 1" 1/2)	1x230 V ~	35	0,043 - 0,32	≤ 0,18	m.c.w.	10
EVOSTA 2 40-70/130 (1/2")	130	DN15 THREADED (G 1")	1x230 V ~	35	0,043 - 0,32	≤ 0,18	m.c.w.	10
EVOSTA 2 40-70/180 (1")	180	DN25 THREADED (G 1" 1/2)	1x230 V ~	35	0,043 - 0,32	≤ 0,18	m.c.w.	10
EVOSTA 2 40-70/180X (1"1/4)	180	DN32 THREADED (G 2")	1x230 V ~	35	0,043 - 0,32	≤ 0,18	m.c.w.	10

The parameter of reference for the more efficient circulators is EEI ≤ 0,18

MODEL	L	L1	B	B1	B2	H	F	PACKING DIMENSIONS			VOLUME m³	WEIGHT Kg
								L	B	H		
EVOSTA 2 40-70/130 (1")	130	96	135	36	99,1	91	1" 1/2	142	99	150	0,0021	2,02
EVOSTA 2 40-70/130 (1/2")	130	96	135	36	99,1	91	1"	142	99	150	0,0021	1,86
EVOSTA 2 40-70/180 (1")	180	96	135	36	99,1	91	1" 1/2	192	99	150	0,0028	2,19
EVOSTA 2 40-70/180X (1"1/4)	180	96	135	36	99,1	91	2"	192	99	150	0,0028	2,35

EVOSTA 3

WET ROTOR ELECTRONIC CIRCULATORS



TECHNICAL DATA

Operating range: 0,4-4,2 m³/h with head up to 8+ metres.

Pumped liquid temperature range: from -10 °C to +110°C

Working pressure: 10 bar (1000 kPa)

Protection class: IPX5

Insulation class: F

Installation: with horizontal motor axis.

Standard power input: single-phase 1x230 V~ 50/60 Hz

Pumped liquid Clean, free of solids and mineral oils, non-viscous, chemically neutral, with properties similar to water (glycol max 30%).

APPLICATIONS

Low energy consumption electronic pump for water circulation in all types of domestic heating and cooling systems.

ADVANTAGES

The new range of **EVOSTA 3** circulators by DAB combines the strength of a mechanical circulator with the benefits of the electronic circulator.

Thanks to the permanent magnet synchronous motor, the frequency converter and the energy efficiency of $EEL \leq 0.19$, as well as the protection class IPX5 and the integrated bleeding plug, the **EVOSTA 3** family ranks as one of the best products in the category in terms of performance and reliability. The range of **EVOSTA 3** circulators is the perfect replacement for old three-speed circulators due to its compact size and all-round performance. The product is also extremely user-friendly, with a single button for sequential setting and direct access to the motor shaft for unlocking it when necessary.

EVOSTA 3 version has a display showing the instantaneous flow rate, the instantaneous head and the instantaneous power consumption in Watts.

EVOSTA 3 version also offers the new function of automatic degassing.

CONSTRUCTION FEATURES

Cast iron pump body with cathodolysis paint coating and wet rotor motor. Steel motor casing, technopolymer impeller. Ceramic motor shaft on ceramic bushings lubricated by the pumped liquid. Stainless steel rotor liner, stator liner and closing flange. Graphite thrust ring.

EPDM seal ring and brass bleeding plug.

Thanks to the internal protection of the motor, the pump does not require any overload protection.

CONTROL PANEL

The settings of the **EVOSTA 2**, **EVOSTA 3** circulators can be modified in the control panel on the face of the pump device. The pumps have nine settings that can be selected scrolling the **MODE** button. Three LED lights on the face show the current setting.

EVOSTA 3 circulator has a display showing the following data:

- Head of the selected curve
- Instantaneous power consumption in Watts.
- Instantaneous head in m
- Instantaneous flow rate in m³/h

EVOSTA 3

WET ROTOR ELECTRONIC CIRCULATORS

WET ROTOR ELECTRONIC CIRCULATORS

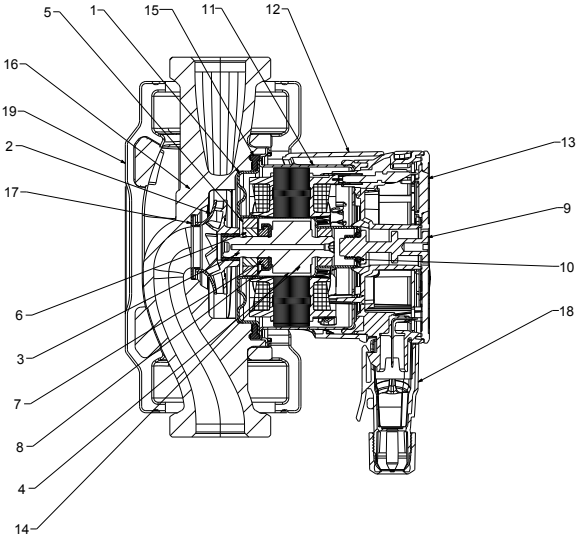

MATERIALS

N°	PARTS	MATERIALS
1	ROTOR CAN FLANGE	AISI 316
2	IMPELLER	ULTRASON
3	SHAFT	ALLUMINA
4	ROTOR	Fe
5	BEARING HOUSING	BRASS
6	BEARING	ALLUMINA
7	AXIAL BEARING	GRAPHITE
8	AXIAL HOUSING	EPDM
9	PLUG	BRASS
10	O-RING	EPDM
11	STATOR HOUSING	AISI 304
12	ENCLOSURE SHELL	POLYCARBONATE
13	ENCLOSURE	POLYCARBONATE
14	ROTOR SLEEVE	AISI 304
15	SEAL	EPDM
16	PUMP HOUSING	CAST IRON
17	NECK RING	AISI 304
18	CONNECTOR	POLYCARBONATE
19	INSULATION SHELL	PPE



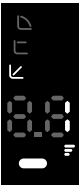

REGULATION MODES

PROPORTIONAL PRESSURE REGULATION MODE



PP1
PP2
PP3

CONSTANT PRESSURE REGULATION MODE

CP1
CP2
CP3

FIXED CURVE REGULATION MODE

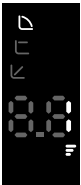
I
II
III

Model Number (example)



EVOSTA 3 - WET ROTOR ELECTRONIC CIRCULATORS

Pumped liquid temperature range: from -10 °C to +110 °C - Maximum operating pressure: 10 bar (1000 kPa)

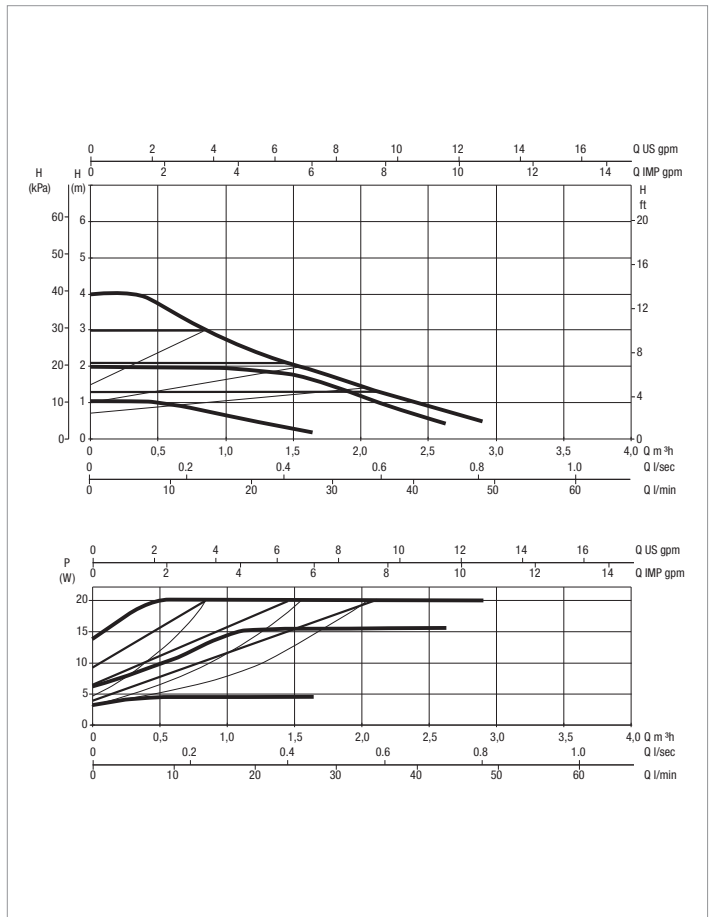
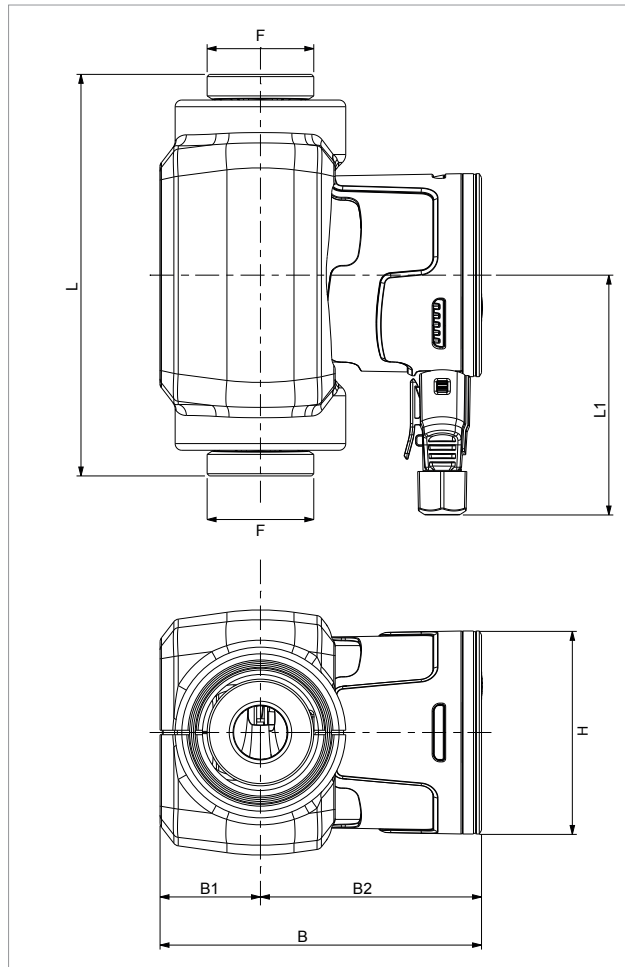

The performance curves are based on kinematic viscosity values = 1 mm²/s and density equal to 1000 kg/m³. Curve tolerance according to ISO 9906.

MODEL	Q=m³h	0	0,4	0,6	0,9	1,2	1,8	2,1	2,9
	Q=l/min	0	6	10	15	20	30	35	48
EVOSTA 3 40/130 (1")	H (m)	4,0	4,0	3,5	2,9	2,5	1,7	1,3	0,5
EVOSTA 3 40/130 (1/2")		4,0	4,0	3,5	2,9	2,5	1,7	1,3	0,5
EVOSTA 3 40/180 (1")		4,0	4,0	3,5	2,9	2,5	1,7	1,3	0,5
EVOSTA 3 40/180 X (1" 1/4)		4,0	4,0	3,5	2,9	2,5	1,7	1,3	0,5

MODEL	CENTRE DISTANCE mm	PUMP CONNECTIONS	POWER INPUT 50 Hz	P1 MAX W	In A	EEI*	MINIMUM SUCTION PRESSURE	
							t°	90°
EVOSTA 3 40/130 (1")	130	DN25 THREADED (G - 1" ½)	1x230 V ~	20	0,034 - 0,18	≤ 0,17	m.c.w.	10
EVOSTA 3 40/130 (1/2")	130	DN15 THREADED (G - 1")	1x230 V ~	20	0,034 - 0,18	≤ 0,17	m.c.w.	10
EVOSTA 3 40/180 (1")	180	DN25 THREADED (G - 1" ½)	1x230 V ~	20	0,034 - 0,18	≤ 0,17	m.c.w.	10
EVOSTA 3 40/180 X (1" 1/4)	180	DN32 THREADED (G - 2")	1x230 V ~	20	0,034 - 0,18	≤ 0,17	m.c.w.	10

*The parameter of reference for the more efficient circulators is EEI ≤ 0,19

MODEL	L	L1	B	B1	B2	H	F	PACKING DIMENSIONS			VOLUME m³	WEIGHT Kg
								L	B	H		
EVOSTA 3 40/130 (1")	130	107,5	144,1	45	99,1	91	1" ½	192	113,5	155	0,0034	2,05
EVOSTA 3 40/130 (1/2")	130	107,5	144,1	45	99,1	91	1"	192	113,5	155	0,0034	1,9
EVOSTA 3 40/180 (1")	180	107,5	144,1	45	99,1	91	1" ½	192	113,5	155	0,0034	2,22
EVOSTA 3 40/180 X (1" 1/4)	180	107,5	144,1	45	99,1	91	2"	192	113,5	155	0,0034	2,38

EVOSTA 3 - WET ROTOR ELECTRONIC CIRCULATORS

Pumped liquid temperature range: from -10 °C to +110 °C - Maximum operating pressure: 10 bar (1000 kPa)

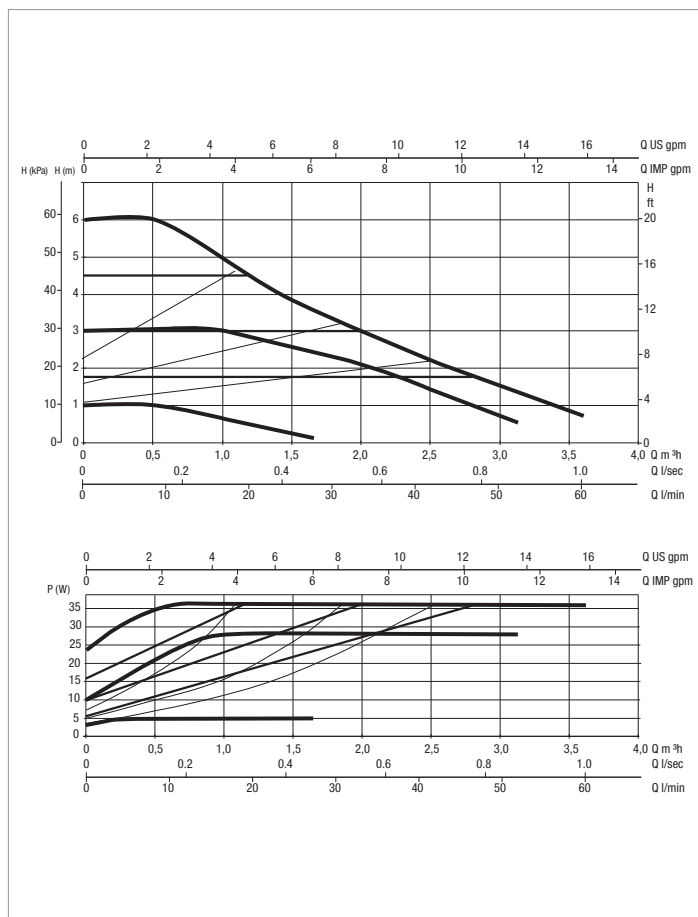
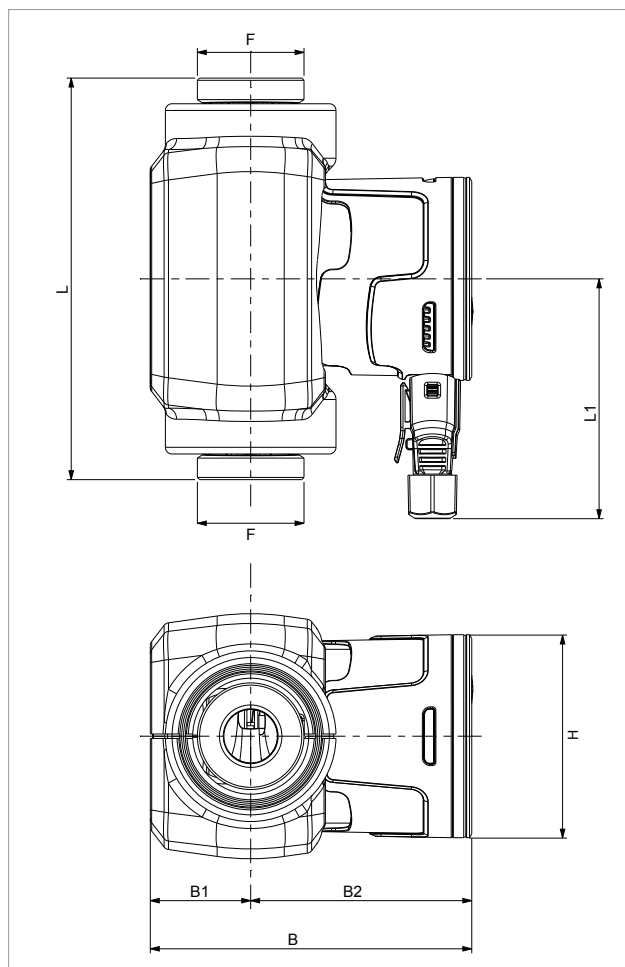

The performance curves are based on kinematic viscosity values = 1 mm²/s and density equal to 1000 kg/m³. Curve tolerance according to ISO 9906.

MODEL	Q=m ³ h	0	0,6	1,2	1,5	2,1	2,4	3,0	3,6
	Q=l/min	0	9	20	25	35	40	50	60
EVOSTA 3 60/130 (1")	H (m)	6,0	6,0	4,4	3,8	2,8	2,3	1,5	0,7
EVOSTA 3 60/130 (1/2")		6,0	6,0	4,4	3,8	2,8	2,3	1,5	0,7
EVOSTA 3 60/180 (1")		6,0	6,0	4,4	3,8	2,8	2,3	1,5	0,7
EVOSTA 3 60/180X (1" 1/4)		6,0	6,0	4,4	3,8	2,8	2,3	1,5	0,7

MODEL	CENTRE DISTANCE mm	PUMP CONNECTIONS	POWER INPUT 50 Hz	P1 MAX W	In A	EEI *	MINIMUM SUCTION PRESSURE	
							t°	90°
EVOSTA 3 60/130 (1")	130	DN25 THREADED (G 1" ½)	1x230 V ~	35	0,042 - 0,33	≤ 0,18	m.c.w.	10
EVOSTA 3 60/130 (1/2")	130	DN15 THREADED (G 1")	1x230 V ~	35	0,042 - 0,33	≤ 0,18	m.c.w.	10
EVOSTA 3 60/180 (1")	180	DN25 THREADED (G 1" ½)	1x230 V ~	35	0,042 - 0,33	≤ 0,18	m.c.w.	10
EVOSTA 3 60/180X (1" 1/4)	180	DN32 THREADED (G 2")	1x230 V ~	35	0,042 - 0,33	≤ 0,18	m.c.w.	10

*The parameter of reference for the more efficient circulators is EEI ≤ 0,19

MODEL	L	L1	B	B1	B2	H	F	PACKING DIMENSIONS			VOLUME m ³	WEIGHT Kg
								L	B	H		
EVOSTA 3 60/130 (1")	130	107,5	144,1	45	99,1	91	1" ½	192	113,5	155	0,0034	2,05
EVOSTA 3 60/130 (1/2")	130	107,5	144,1	45	99,1	91	1"	192	113,5	155	0,0034	1,9
EVOSTA 3 60/180 (1")	180	107,5	144,1	45	99,1	91	1" ½	192	113,5	155	0,0034	2,22
EVOSTA 3 60/180X (1" 1/4)	180	107,5	144,1	45	99,1	91	2"	192	113,5	155	0,0034	2,38

EVOSTA 3 - WET ROTOR ELECTRONIC CIRCULATORS

Pumped liquid temperature range: from -10 °C to +110 °C - Maximum operating pressure: 10 bar (1000 kPa)

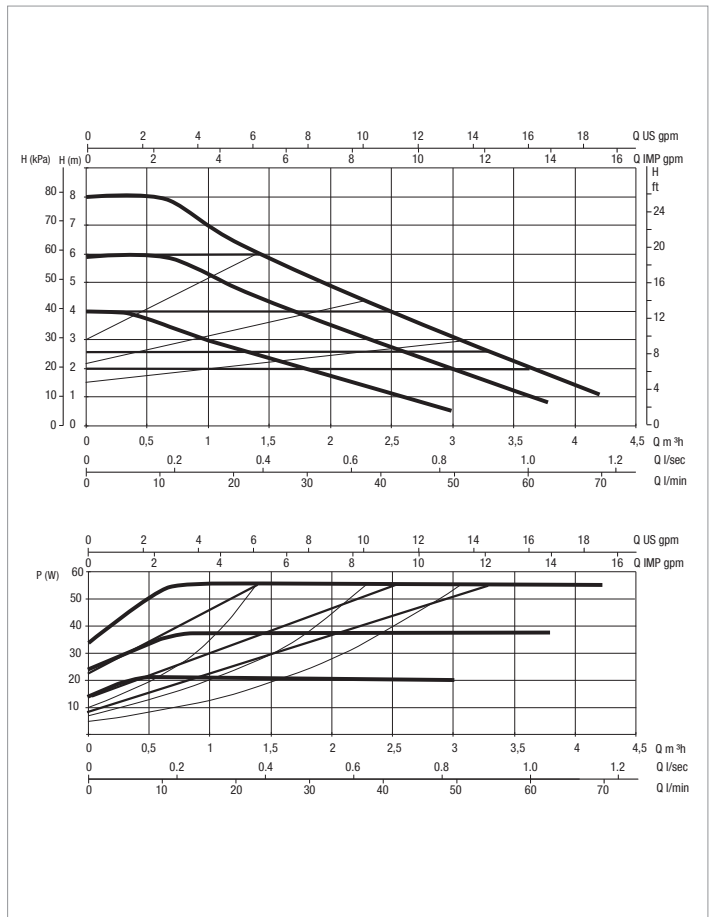
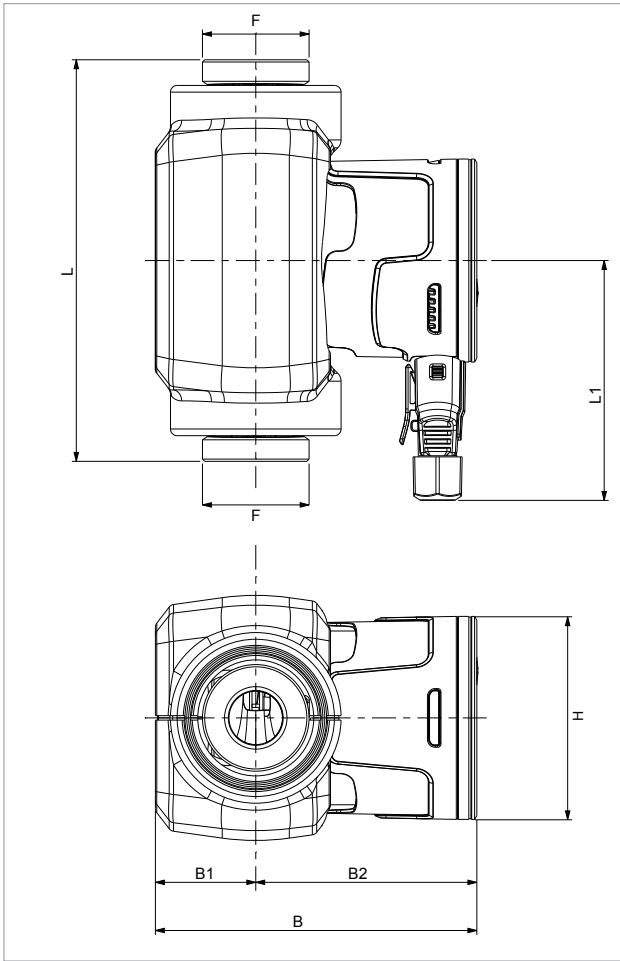

The performance curves are based on kinematic viscosity values = 1 mm²/s and density equal to 1000 kg/m³. Curve tolerance according to ISO 9906.

MODEL	Q=m³h	0	0,6	0,9	1,2	2,7	3,3	3,9	4,2
	Q=l/min	0	10	15	20	45	55	65	70
EVOSTA 3 80/130 (1")	H (m)	8,0	8,0	7,2	6,5	3,7	2,6	1,6	1,0
EVOSTA 3 80/130 (1/2")		8,0	8,0	7,2	6,5	3,7	2,6	1,6	1,0
EVOSTA 3 80/180 (1")		8,0	8,0	7,2	6,5	3,7	2,6	1,6	1,0
EVOSTA 3 80/180X (1" 1/4)		8,0	8,0	7,2	6,5	3,7	2,6	1,6	1,0

MODEL	CENTRE DISTANCE mm	PUMP CONNECTIONS	POWER INPUT 50 Hz	P1 MAX W	In A	EEI*	MINIMUM SUCTION PRESSURE	
							t°	90°
EVOSTA 3 80/130 (1")	130	DN25 THREADED (G 1" ½)	1x230 V ~	55	0,053 -0,47	≤ 0,19	m.c.w.	10
EVOSTA 3 80/130 (1/2")	130	DN15 THREADED (G 1")	1x230 V ~	55	0,053 -0,47	≤ 0,19	m.c.w.	10
EVOSTA 3 80/180 (1")	180	DN25 THREADED (G 1" ½)	1x230 V ~	55	0,053 -0,47	≤ 0,19	m.c.w.	10
EVOSTA 3 80/180X (1" 1/4)	180	DN32 THREADED (G 2")	1x230 V ~	55	0,053 -0,47	≤ 0,19	m.c.w.	10

*The parameter of reference for the more efficient circulators is EEI ≤ 0,19

MODEL	L	L1	B	B1	B2	H	F	PACKING DIMENSIONS			VOLUME m³	WEIGHT Kg
								L	B	H		
EVOSTA 3 80/130 (1")	130	107.5	144.1	45	99.1	91	1" ½	192	113,5	155	0,0034	2,05
EVOSTA 3 80/130 (1/2")	130	107.5	144.1	45	99.1	91	1"	192	113,5	155	0,0034	1,9
EVOSTA 3 80/180 (1")	180	107.5	144.1	45	99.1	91	1" ½	192	113,5	155	0,0034	2,22
EVOSTA 3 80/180X (1" 1/4)	180	107.5	144.1	45	99.1	91	2"	192	113,5	155	0,0034	2,38

EVOSTA 2 SOL

WET ROTOR ELECTRONIC CIRCULATORS



TECHNICAL DATA

Operating range: 0-4 m³/h with head up to 14,5 metres

Pumped liquid temperature range: from -10 °C to +110 °C
(130 °C to 60 °C ambient)

Working pressure: 10 bar (1000 kPa)

Protection class: IPX4

Insulation class: F

Installation: with horizontal motor axis

Standard power input: single-phase 1x115-230 V ~ 50/60 Hz

Power input connection: molex plug with 1.5m cable

Pwm signal connector: plug with 1.5m cable (OEM versions only)

Pumped liquid: Clean, free of solids and mineral oils, non-viscous, chemically neutral, with properties similar to water (glycol max 50%)

APPLICATIONS

Low energy consumption electronic pump for hot water circulation in all types of solar heating systems.

ADVANTAGES

EVOSTA 2 SOL is the new range of DAB circulators that combines the strength of the mechanical circulator with the benefits of the electronic circulator.

Thanks to the permanent magnet synchronous motor, the frequency converter and the energy efficiency index of $EEL \leq 0.20$, as well as the IPX4 protection class and the integrated breather plug, the EVOSTA 2 SOL family ranks as one of the best products in the category in terms of performance and reliability. The range of EVOSTA 2 SOL circulators is the perfect substitute for old three-speed circulators due to its compact size and all-round performance.

The product is also extremely user-friendly, with a single key for sequential setting and direct access to the motor shaft for unlocking this when necessary.

CONSTRUCTION FEATURES

Cast iron pump body with cataphoresis paint coating and wet rotor motor. Steel motor casing, technopolymer impeller. Ceramic motor shaft on ceramic bushings lubricated by the pumped liquid. Stainless steel rotor liner, stator liner and closing flange. Graphite thrust ring. EPDM seal ring and brass air breather plug.

Thanks to the internal protection of the motor, the pump does not require overload protection.

CONTROL PANEL

The functions of the EVOSTA 2 SOL circulators can be modified at the control panel on the cover of the electronic control device. The pump has nine settings that can be selected using the MODE button

Six illuminated segments on the display indicate the settings of the pump. The EVOSTA SOL PWM version can be controlled from an external control unit using the PWM (Pulse Width Modulation) digital signal. The setpoint of the adjustment curve can be of the following types:

- Proportional pressure
- Constant speed.

This is set through the PWM signal duty cycle, applied according to the VDMA Einheitsblatt 24244 standard "Wet runner circulating pumps – Specification of PWM control signals".

Moreover, a PWM signal on the output of the board indicates the operating mode of the circulator, as specified below.

EVOSTA 2 SOL

WET ROTOR ELECTRONIC CIRCULATORS

MATERIALS

N°	PARTS	MATERIALS
1	ROTOR CAN FLANGE	AISI 316
2	IMPELLER	ULTRASON
3	SHAFT	ALLUMINA
4	ROTOR	Fe
5	BEARING HOUSING	BRASS
6	BEARING	ALLUMINA
7	AXIAL BEARING	GRAPHITE
8	AXIAL HOUSING	EPDM
9	PLUG	BRASS
10	O-RING	EPDM
11	STATOR HOUSING	AISI 304
12	ENCLOSURE SHELL	POLYCARBONATE
13	ENCLOSURE	POLYCARBONATE
14	ROTOR SLEEVE	AISI 304
15	SEAL	EPDM
16	PUMP HOUSING	CAST IRON
17	NECK RING	AISI 304
18	CONNECTOR	POLYCARBONATE

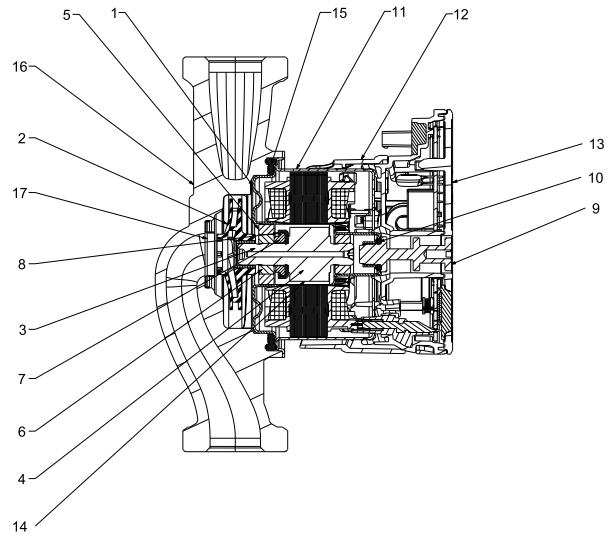

REGULATION MODES

PROPORTIONAL PRESSURE REGULATION MODE

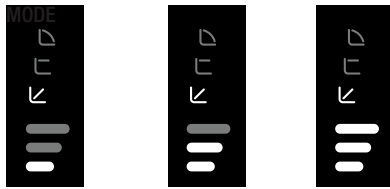

PP1

PP2

PP3

CONSTANT PRESSURE REGULATION

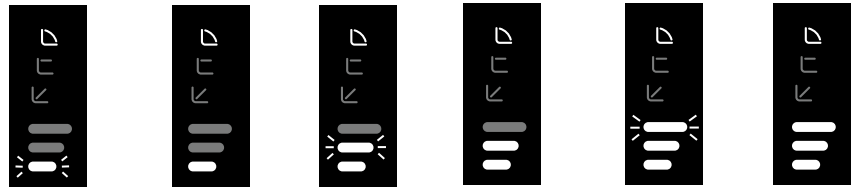

I

II

III

IV

V

VI

Model Number (example)

EVOSTA 2 SOL 20/75 130 X

Threaded connections electronic circulator _____
 Maximum head range (dm) _____

Centre distance (mm) _____

Standard (no ref.) = 1" ½ threaded connections
 ½" = 1" threaded connections
 X = 2" threaded connections

EVOSTA 2 SOL - WET ROTOR ELECTRONIC CIRCULATORS

Pumped liquid temperature range: da -10°C a +110°C - Maximum operating pressure: 10 bar (1000 kPa)

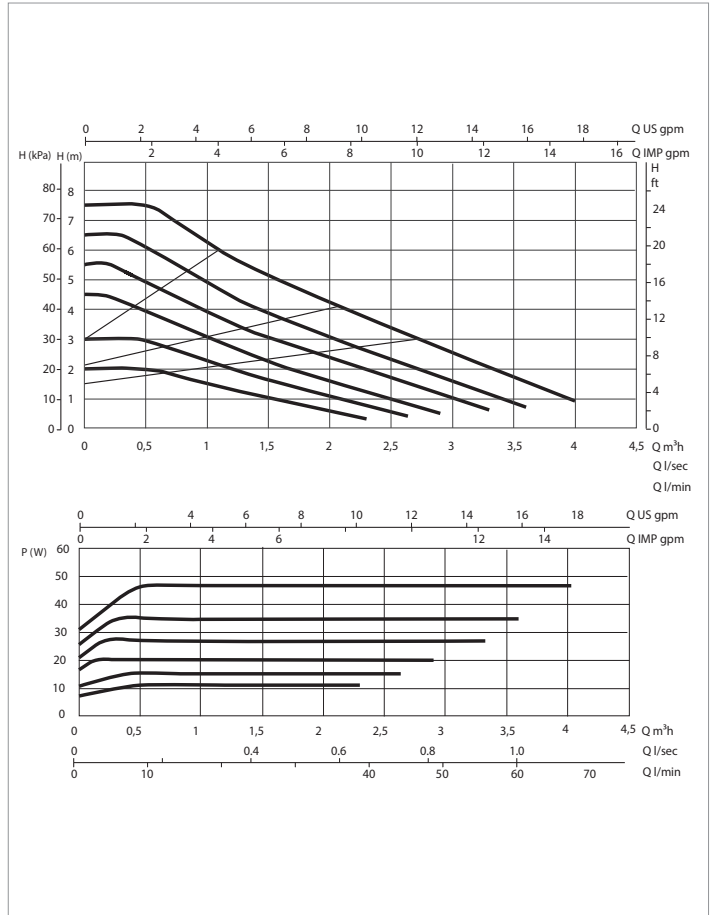
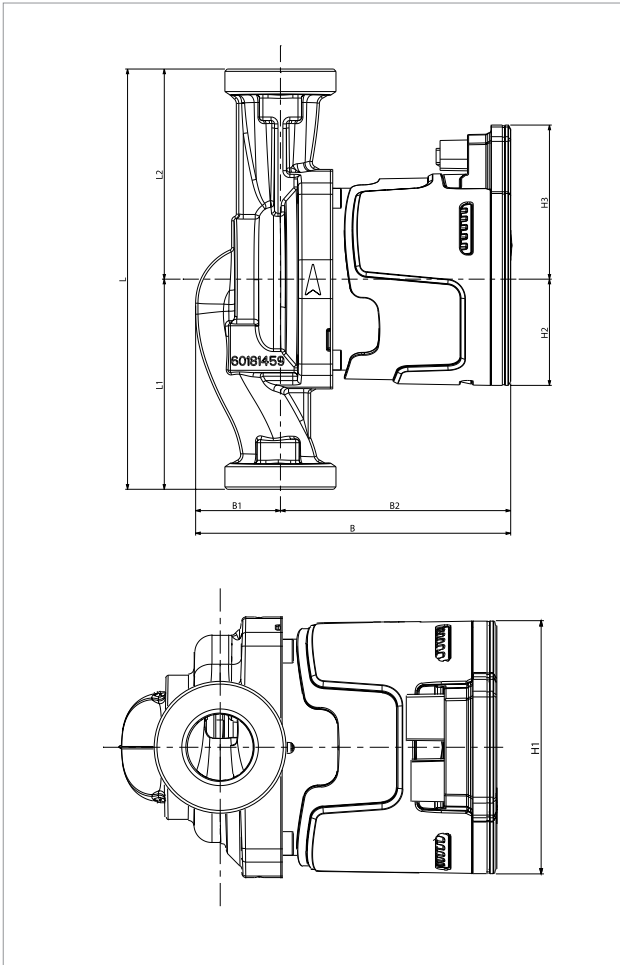

The performance curves are based on kinematic viscosity values = 1 mm²/s and density equal to 1000 kg/m³. Curve tolerance according to ISO 9906.

MODEL	CENTRE DISTANCE mm	PUMP CONNECTIONS	SIGNAL PWM	POWER INPUT 50 Hz	P1 MAX W	In A	EEI*	MINIMUM SUCTION PRESSURE	
								t°	90°
EVOSTA 2 20-75/130 SOL (1")	130	DN25 THREADED (G 1" ½)	NO	1x230 V ~	47	0,07-0,4	≤ 0,20	m.c.w.	10
EVOSTA 2 20-75/180 SOL (1")	180	DN25 THREADED (G 1" ½)	NO	1x230 V ~	47	0,07-0,4	≤ 0,20	m.c.w.	10
EVOSTA 2 20-75/130 SOL (1/2")	130	DN15 THREADED (G 1")	NO	1x230 V ~	47	0,07-0,4	≤ 0,20	m.c.w.	10
EVOSTA 2 20-75/130 SOL PWM (1")	130	DN25 THREADED (G 1" ½)	YES	1x230 V ~	47	0,07-0,4	≤ 0,20	m.c.w.	10
EVOSTA 2 20-75/130 SOL PWM (1/2")	130	DN15 THREADED (G 1")	YES	1x230 V ~	47	0,07-0,4	≤ 0,20	m.c.w.	10
EVOSTA 2 20-75/180 SOL PWM (1")	180	DN25 THREADED (G 1" ½)	YES	1x230 V ~	47	0,07-0,4	≤ 0,20	m.c.w.	10

*The parameter of reference for the more efficient circulators is EEI ≤ 0,20

MODEL	L	L1	L2	B	B1	B2	H	H1	H2	H3	F	PACKING DIMENSIONS			VOLUME m³	WEIGHT Kg
												L	B	H		
EVOSTA 2 20-75/130 SOL (1")	130	65	65	135	36	99	94	91	45,5	66	1"1/2	192	100	150	0,028	2,07
EVOSTA 2 20-75/180 SOL (1")	180	90	90	135	36	99	94	91	45,5	66	1"1/2	192	100	150	0,028	2,24
EVOSTA 2 20-75/130 SOL (1/2")	130	65	65	135	36	99	94	91	45,5	66	1"	192	100	150	0,028	1,91
EVOSTA 2 20-75/130 SOL PWM (1")	130	65	65	135	36	99	94	91	45,5	66	1"1/2	192	100	150	0,028	2,12
EVOSTA 2 20-75/130 SOL PWM (1/2")	130	65	65	135	36	99	94	91	45,5	66	1"	192	100	150	0,028	1,96
EVOSTA 2 20-75/180 SOL PWM (1")	180	90	90	135	36	99	94	91	45,5	66	1"1/2	192	100	150	0,028	2,29

EVOSTA 2 SOL - WET ROTOR ELECTRONIC CIRCULATORS

Pumped liquid temperature range: da -10°C a +110°C - Maximum operating pressure: 10 bar (1000 kPa)

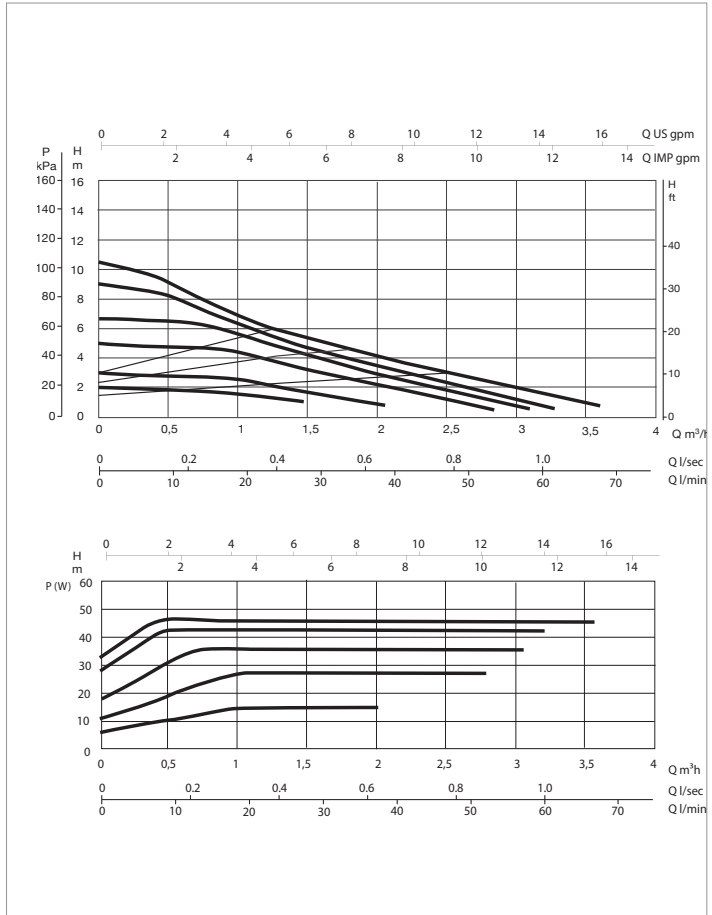
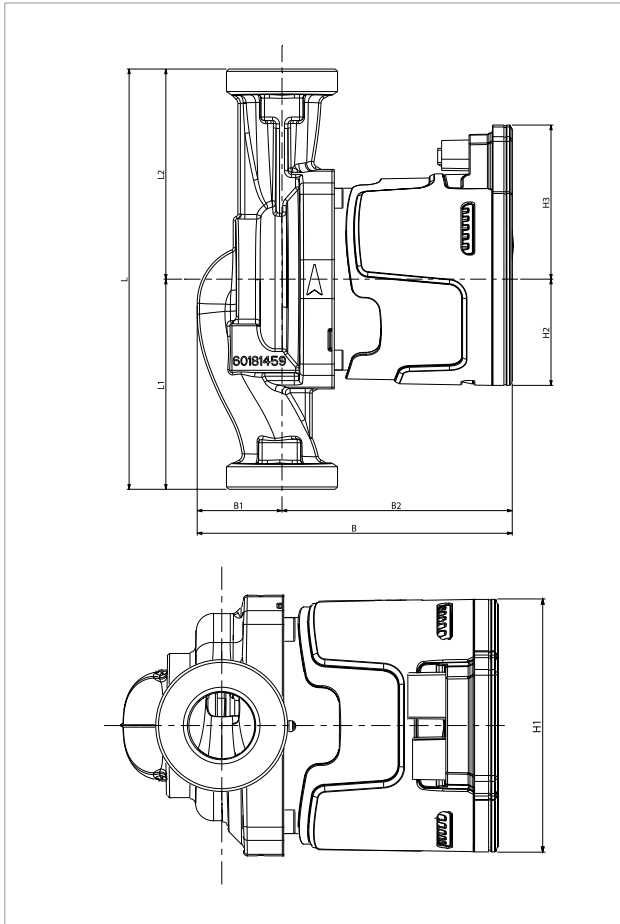

The performance curves are based on kinematic viscosity values = 1 mm²/s and density equal to 1000 kg/m³. Curve tolerance according to ISO 9906.

MODEL	CENTRE DISTANCE mm	PUMP CONNECTIONS	SIGNAL PWM	POWER INPUT 50 Hz	P1 MAX W	In A	EEI *	MINIMUM SUCTION PRESSURE	
								t°	90°
EVOSTA 2 20-105/130 SOL (1")	130	DN25 THREADED (G 1" ½)	NO	1x230 V ~	48	0,055-0,4	≤ 0,20	m.c.w.	10
EVOSTA 2 20-105/180 SOL (1")	180	DN25 THREADED (G 1" ½)	NO	1x230 V ~	48	0,055-0,4	≤ 0,20	m.c.w.	10
EVOSTA 2 20-105/130 SOL (1/2")	130	DN15 THREADED (G 1")	NO	1x230 V ~	48	0,055-0,4	≤ 0,20	m.c.w.	10
EVOSTA 2 20-105/130 SOL PWM (1")	130	DN25 THREADED (G 1" ½)	YES	1x230 V ~	48	0,055-0,4	≤ 0,20	m.c.w.	10
EVOSTA 2 20-105/130 SOL PWM (1/2")	130	DN15 THREADED (G 1")	YES	1x230 V ~	48	0,055-0,4	≤ 0,20	m.c.w.	10
EVOSTA 2 20-105/180 SOL PWM(1")	180	DN25 THREADED (G 1" ½)	YES	1x230 V ~	48	0,055-0,4	≤ 0,20	m.c.w.	10

*The parameter of reference for the more efficient circulators is EEI ≤ 0,20

MODEL	L	L1	L2	B	B1	B2	H	H1	H2	H3	F	PACKING DIMENSIONS			VOLUME m³	WEIGHT Kg
												L	B	H		
EVOSTA 2 20-105/130 SOL (1")	130	65	65	135	36	99	94	91	45,5	66	1"1/2	192	100	150	0,028	2,07
EVOSTA 2 20-105/180 SOL (1")	180	90	90	135	36	99	94	91	45,5	66	1"1/2	192	100	150	0,028	2,24
EVOSTA 2 20-105/130 SOL (1/2")	130	65	65	135	36	99	94	91	45,5	66	1"	192	100	150	0,028	1,91
EVOSTA 2 20-105/130 SOL PWM (1")	130	65	65	135	36	99	94	91	45,5	66	1"1/2	192	100	150	0,028	2,12
EVOSTA 2 20-105/130 SOL PWM (1/2")	130	65	65	135	36	99	94	91	45,5	66	1"	192	100	150	0,028	1,96
EVOSTA 2 20-105/180 SOL PWM(1")	180	90	90	135	36	99	94	91	45,5	66	1"1/2	192	100	150	0,028	2,29

EVOSTA 2 SOL - WET ROTOR ELECTRONIC CIRCULATORS

Pumped liquid temperature range: da -10°C a +110°C - Maximum operating pressure: 10 bar (1000 kPa)

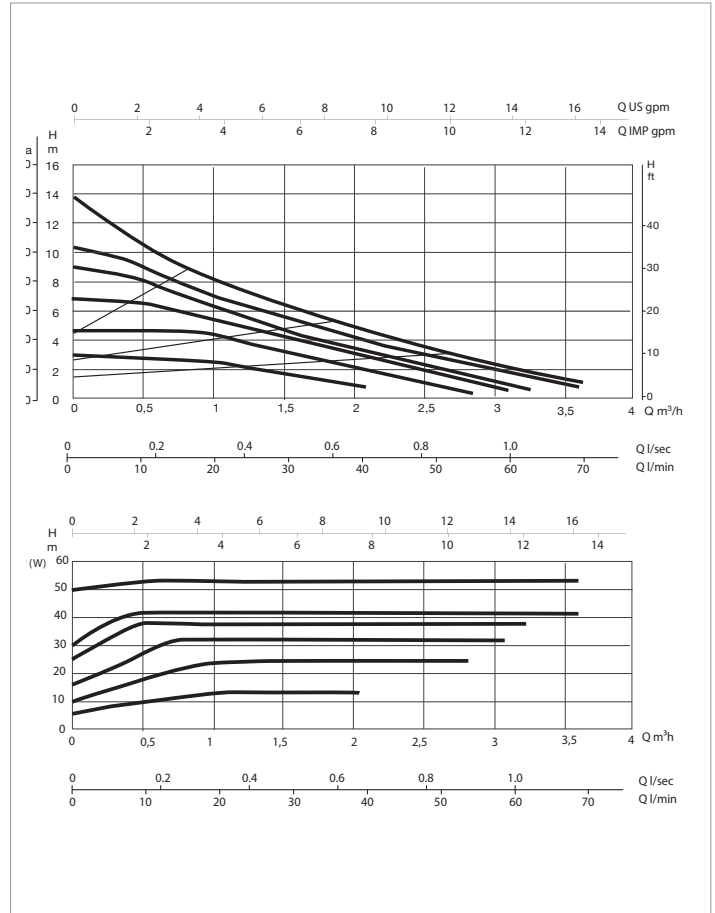
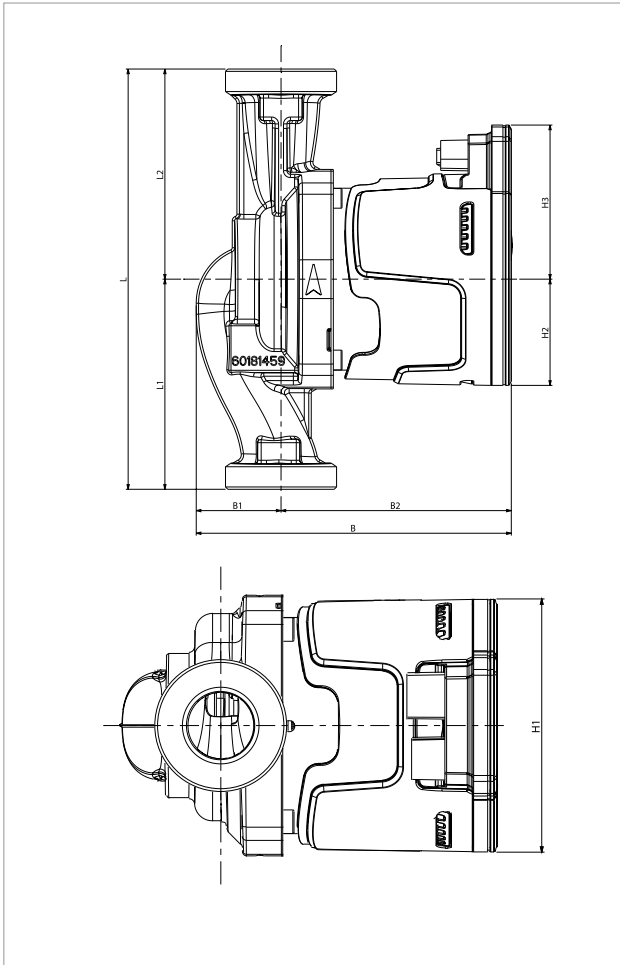

The performance curves are based on kinematic viscosity values = 1 mm²/s and density equal to 1000 kg/m³. Curve tolerance according to ISO 9906.

MODEL	CENTRE DISTANCE mm	PUMP CONNECTIONS	SIGNAL PWM	POWER INPUT 50 Hz	P1 MAX W	In A	EEI*	MINIMUM SUCTION PRESSURE	
								t°	90°
EVOSTA 2 30-145/130 SOL (1")	130	DN25 THREADED (G 1" ½)	NO	1x230 V ~	59	0,07-0,5	≤ 0,20	m.c.w.	10
EVOSTA 2 30-145/180 SOL (1")	180	DN25 THREADED (G 1" ½)	NO	1x230 V ~	59	0,07-0,5	≤ 0,20	m.c.w.	10
EVOSTA 2 30-145/130 SOL (1/2")	130	DN15 THREADED (G 1")	NO	1x230 V ~	59	0,07-0,5	≤ 0,20	m.c.w.	10
EVOSTA 2 30-145/130 SOL PWM (1")	130	DN25 THREADED (G 1" ½)	YES	1x230 V ~	59	0,07-0,5	≤ 0,20	m.c.w.	10
EVOSTA 2 30-145/130 SOL PWM (1/2")	130	DN15 THREADED (G 1")	YES	1x230 V ~	59	0,07-0,5	≤ 0,20	m.c.w.	10
EVOSTA 2 30-145/180 SOL PWM (1")	180	DN25 THREADED (G 1" ½)	YES	1x230 V ~	59	0,07-0,5	≤ 0,20	m.c.w.	10

*The parameter of reference for the more efficient circulators is EEI ≤ 0,20

MODEL	L	L1	L2	B	B1	B2	H	H1	H2	H3	F	PACKING DIMENSIONS			VOLUME m³	WEIGHT Kg
												L	B	H		
EVOSTA 2 30-145/130 SOL (1")	130	65	65	135	36	99	94	91	45,5	66	1"1/2	192	100	150	0,028	2,07
EVOSTA 2 30-145/180 SOL (1")	180	90	90	135	36	99	94	91	45,5	66	1"1/2	192	100	150	0,028	2,24
EVOSTA 2 30-145/130 SOL (1/2")	130	65	65	135	36	99	94	91	45,5	66	1"	192	100	150	0,028	1,91
EVOSTA 2 30-145/130 SOL PWM (1")	130	65	65	135	36	99	94	91	45,5	66	1"1/2	192	100	150	0,028	2,12
EVOSTA 2 30-145/130 SOL PWM (1/2")	130	65	65	135	36	99	94	91	45,5	66	1"	192	100	150	0,028	1,96
EVOSTA 2 30-145/180 SOL PWM (1")	180	90	90	135	36	99	94	91	45,5	66	1"1/2	192	100	150	0,028	2,29

EVOSTA 2 SOL - WET ROTOR ELECTRONIC CIRCULATORS

Pumped liquid temperature range: da -10°C a +110°C - Maximum operating pressure: 10 bar (1000 kPa)

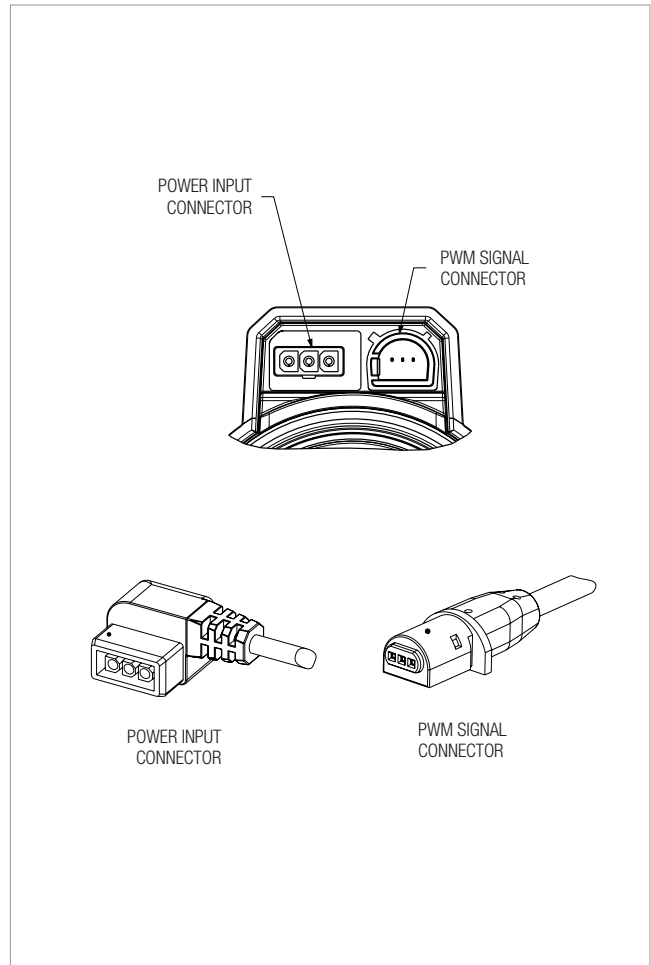
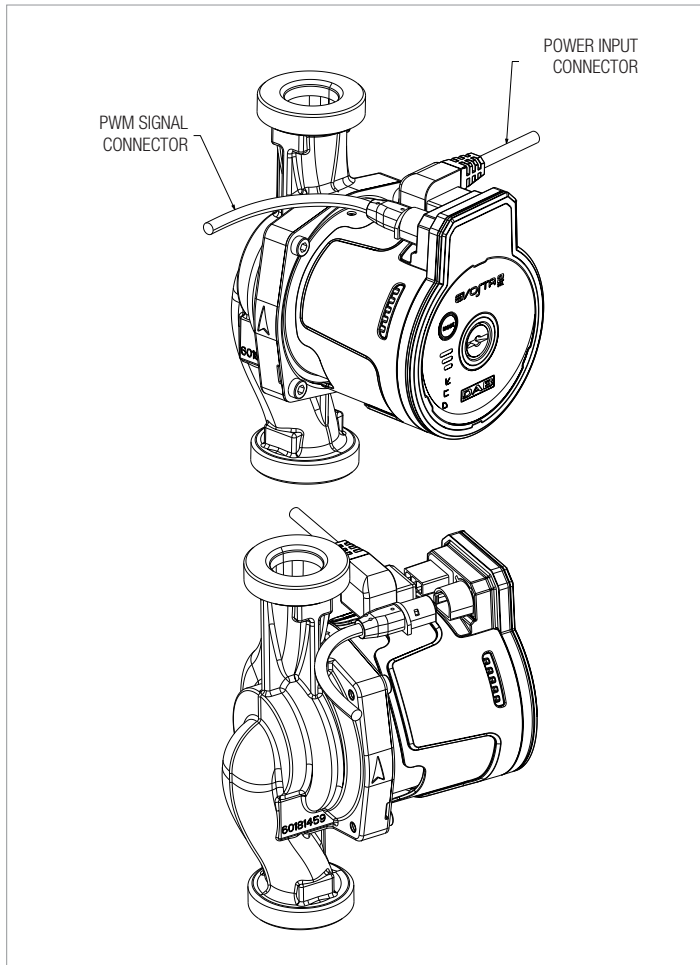

MODEL	CABLE LENGTH
POWER INPUT CONNECTOR	1,5 m
PWM SIGNAL CONNECTOR	1,5 m

EVOSTA 2 SOL - WET ROTOR ELECTRONIC CIRCULATORS

Pumped liquid temperature range: da -10°C a +110°C - Maximum operating pressure: 10 bar (1000 kPa)

INPUT PWM SIGNAL

Inactive level : 0V

Active level da 5V-15V

Active level minimum current : 5 mA

Frequency: 100Hz - 5 kHz

Protection class: Class 2

ESD class Compliance with IEC 61000-4-2 (ESD)

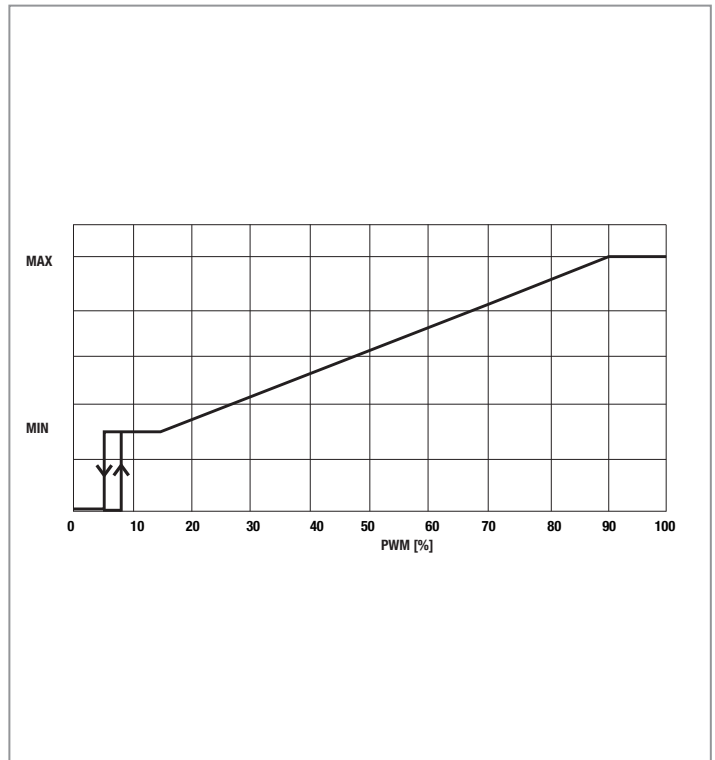

WORKING AREA	DUTY CICLE PWM
STANDBY MODE	< 5%
HYSTERESIS AREA	≥ 5 % / < 9 %
MINIMUM SET POINT	≥ 9 % / < 16 %
VARIABLE SET POINT	≥ 16 % / ≤ 90 %
MAXIMUM SET POINT	≥ 90 % / ≤ 100 %

EVOSTA 2 SOL - WET ROTOR ELECTRONIC CIRCULATORS

Pumped liquid temperature range: da -10°C a +110°C - Maximum operating pressure: 10 bar (1000 kPa)

OUTPUT PWM SIGNAL

Type: Open collector V

Frequency: 5V-15V

Maximum current on output transistor: 50 mA

Maximum power on output resistor: 125 mW

Maximum power on output zener 36 V: 300 mW

Frequency: 75 Hz +/- 2%

Protection class: Class 2

ESD class: Compliance with IEC 61000-4-2 (ESD)

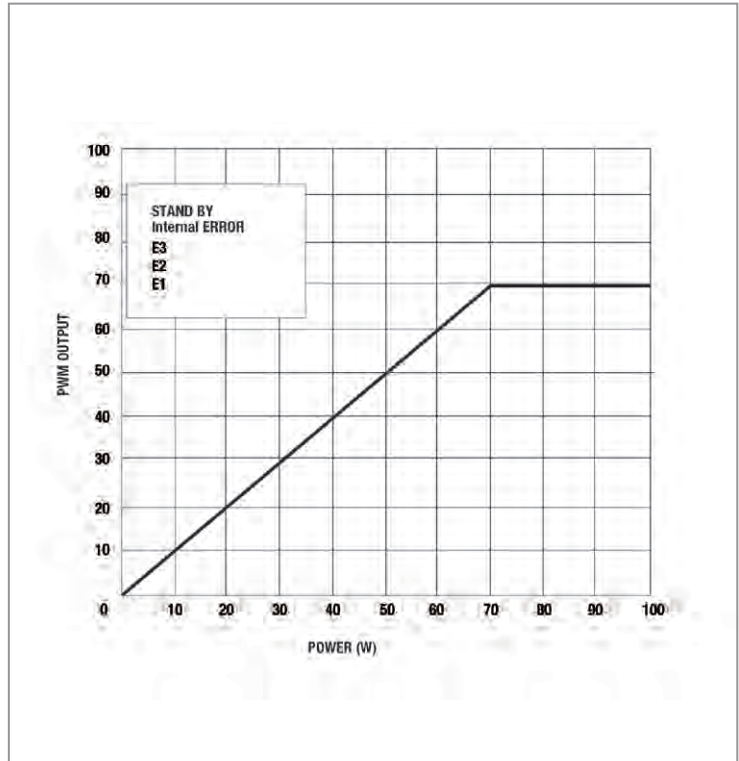

WORKING AREA	DUTY CICLE PWM
RUNNING PUMP	1%-70%
ERROR 1 DRY RUN	75%
ERROR 2 LOCKED ROTOR	80%
ERROR 3 SHORT CIRCUIT	85%
INTERNAL ERROR	90%
STANDBY (STOP) BY PWM INPUT SIGNAL	95%

EVOSTA 2 SAN V/R

WET ROTOR ELECTRONIC CIRCULATORS



TECHNICAL DATA

Operating range: 0-0,6 m³/h with head up to 1,1 metri
Pumped liquid temperature range: : from +2 °C to +75°C
Working pressure: 10 bar (1000 kPa)
Protection class: IP42
Insulation class: II
Installation: with horizontal motor axis.
Standard power input: single-phase 1x115-230 V~ 50/60 Hz
Pumped liquid: Clean, free of solids and mineral oils, non-viscous, chemically neutral, with properties similar to water (glycol max 30%).

APPLICATIONS

Low energy consumption electronic pump for domestic hot water circulation.

CONSTRUCTION FEATURES

Self-protected synchronous motor with spherical rotor requiring just one seal ring between the motor and the pump body. Easy to clean or replace.
 Brass pump body with R ½" (G ½") internal thread in the R version, or with check valve and isolation valve supplied as standard in version V for connector with ½" external thread (G 1")

Model Number: (example)	EVOSTA 2	11/139	V	R
Threaded ports electronic circulator	_____	_____	_____	_____
Maximum head range (dm)	_____	_____	_____	_____
External thread: ½" G 1"	_____	_____	_____	_____
Internal thread: R ½" (G ½")	_____	_____	_____	_____

EVOSTA 2 SAN V/R - WET ROTOR ELECTRONIC CIRCULATORS

Pumped liquid temperature range: from +2 °C to +75°C - Maximum operating pressure: 10 bar (1000 kPa)

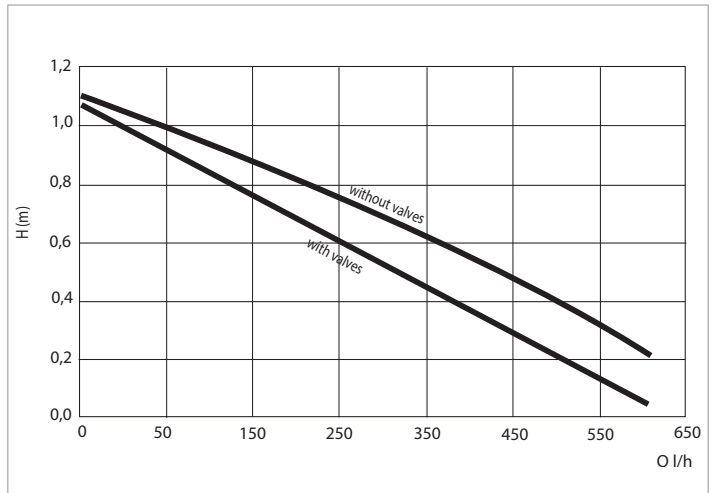
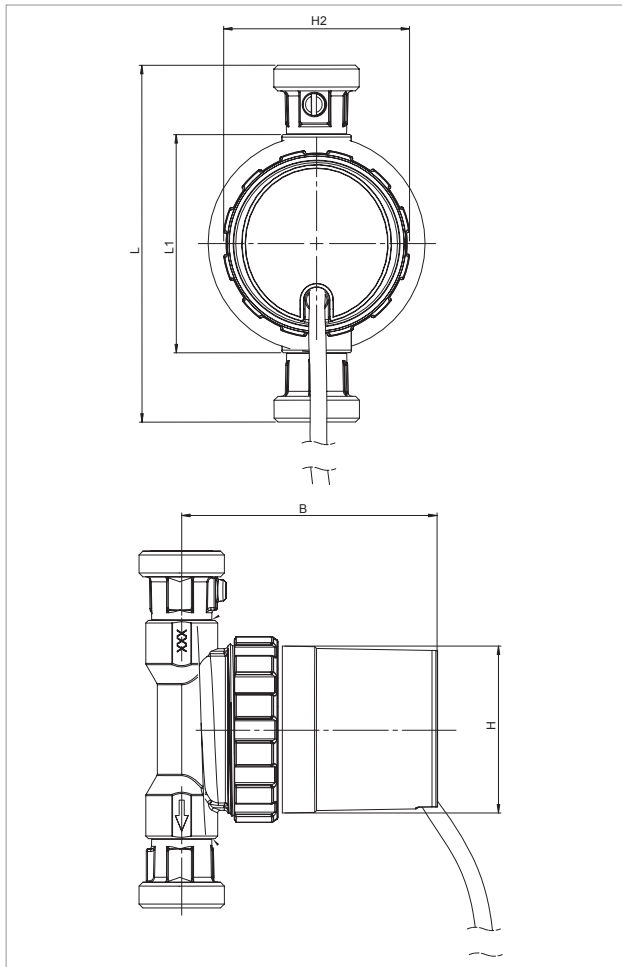

The performance curves are based on kinematic viscosity values = 1 mm²/s and density equal to 1000 kg/m³. Curve tolerance according to ISO 9906.

MODEL	Q=m ³ h	0	0,1	0,2	0,3	0,4	0,5	0,6
	Q=l/h	0	100	200	300	400	500	600
EVOSTA2 11/139 SAN V CIRC.	H (m)	1,1	0,93	0,76	0,59	0,4	0,23	0,7
EVOSTA2 11/85 SAN R1/2" CIRC.		1,1	1	0,87	0,73	0,58	0,4	0,23

MODEL	CENTRE DISTANCE mm	PUMP CONNECTIONS	POWER INPUT 50 Hz	P1 MAX W	In A	MINIMUM SUCTION PRESSURE	
						t°	90°
EVOSTA2 11/139 SAN V CIRC.	139	external thread G 1"	1x115-230 V~ 50/60 Hz	7	0,07	m.c.w.	10
EVOSTA2 11/85 SAN R1/2" CIRC.	85	external thread G 1/2"	1x115-230 V~ 50/60 Hz	7	0,07	m.c.w.	10

MODEL	L	L1	B	H	H2	CABLE LENGHT	PACKING DIMENSIONS			VOLUME m ³	WEIGHT Kg
							L	B	H		
EVOSTA2 11/139 SAN V CIRC.	139	-	100	65	72	1,5 m	175	125	105	0,0023	1,26
EVOSTA2 11/85 SAN R1/2" CIRC.	-	85	100	65	72	1,5 m	175	125	105	0,0023	1,06

EVOSTA 2 SAN

WET ROTOR ELECTRONIC CIRCULATORS



TECHNICAL DATA

Operating range: 0,4-4,2 m³/h with head up to 8 metres.

Pumped liquid temperature range: from -10 °C to +110°C

Working pressure: 10 bar (1000 kPa)

Protection class: IPX5

Insulation class: F

Installation: with horizontal motor axis.

Standard power input: single-phase 1x230 V~ 50/60 Hz

Pumped liquid: Clean, free of solids and mineral oils, non-viscous, chemically neutral, with properties similar to water (glycol max 30%).

APPLICATIONS

Low energy consumption electronic pump for domestic hot water circulation.

ADVANTAGES

The new range of **EVOSTA 2 SAN** circulators by DAB combines the strength of a mechanical circulator with the benefits of an electronic circulator.

Thanks to the permanent magnet synchronous motor, the frequency converter, as well as the protection class IPX5 and the integrated bleeding plug, **EVOSTA 2 SAN** family ranks as one of the best products in the category in terms of performance and reliability. The range of **EVOSTA 2 SAN** circulators is the perfect replacement for old three-speed circulators due to its compact size and all-round performance. The product is also extremely user-friendly, with a single button for sequential setting and direct access to the motor shaft for unlocking it when necessary.

CONSTRUCTION FEATURES

Bronze pump body and wet rotor motor. Steel motor casing, technopolymer impeller. Ceramic motor shaft on ceramic bushings lubricated by the pumped liquid. Stainless steel rotor liner and closing flange. Graphite thrust ring. EPDM seal ring and brass air bleeding plug.

Thanks to the internal protection of the motor, the pump does not require any overload protection.

CONTROL PANEL

The settings of **EVOSTA 2 SAN** circulators can be modified in the control panel on the face of the pump. The pump has nine settings that can be selected scrolling the **MODE** button. Six illuminated segments on the display indicate the settings of the pump.

EVOSTA 2 SAN

WET ROTOR ELECTRONIC CIRCULATORS

MATERIALS

N°	PARTS	MATERIALS
1	ROTOR CAN FLANGE	AISI 316
2	IMPELLER	ULTRASON
3	SHAFT	ALLUMINA
4	ROTOR	Fe
5	BEARING HOUSING	BRASS
6	BEARING	ALLUMINA
7	AXIAL BEARING	GRAPHITE
8	AXIAL HOUSING	EPDM
9	PLUG	BRASS
10	O-RING	EPDM
11	STATOR HOUSING	AISI 304
12	ENCLOSURE SHELL	POLYCARBONATE
13	ENCLOSURE	POLYCARBONATE
14	ROTOR SLEEVE	AISI 304
15	SEAL	EPDM
16	PUMP HOUSING	BRONZE
17	NECK RING	AISI 304
18	CONNECTOR	POLYCARBONATE

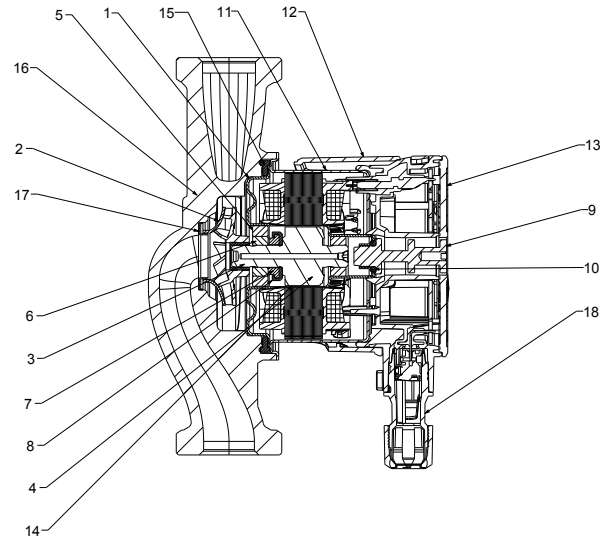

REGULATION MODES

PROPORTIONAL PRESSURE REGULATION MODE

PP1
PP2
PP3

CONSTANT PRESSURE REGULATION MODE

CP1
CP2
CP3

FIXED CURVE REGULATION MODE

I
II
III

Model Number:
(example)

EVOSTA 2 SAN

40/70

150

Threaded connection electronic circulator

Maximum head range (dm)

Centre distance (mm)

EVOSTA 2 SAN - WET ROTOR ELECTRONIC CIRCULATORS

Pumped liquid temperature range: from -10 °C to +110 °C - Maximum operating pressure: 10 bar (1000 kPa)

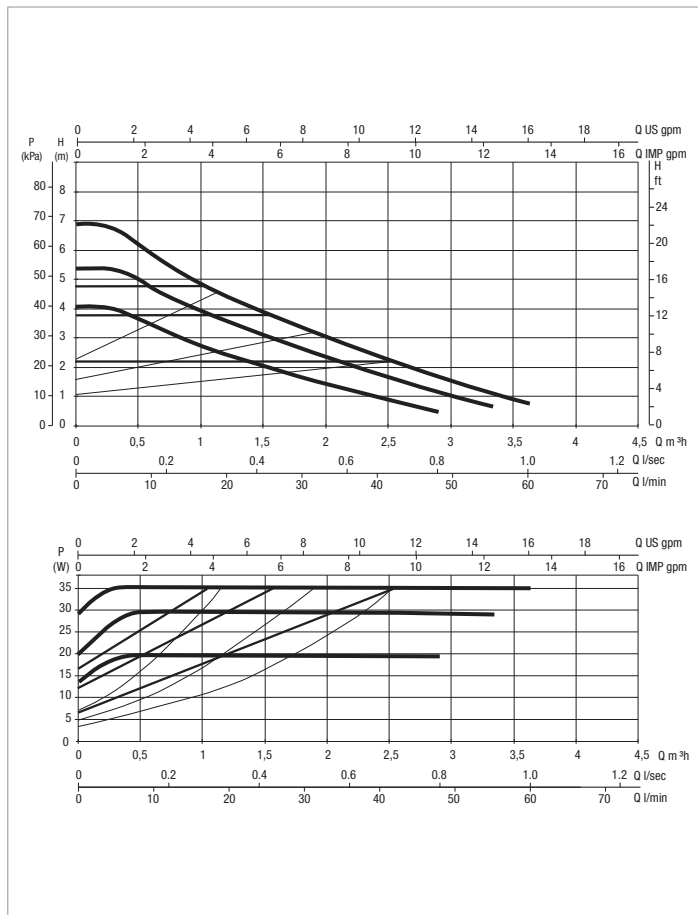
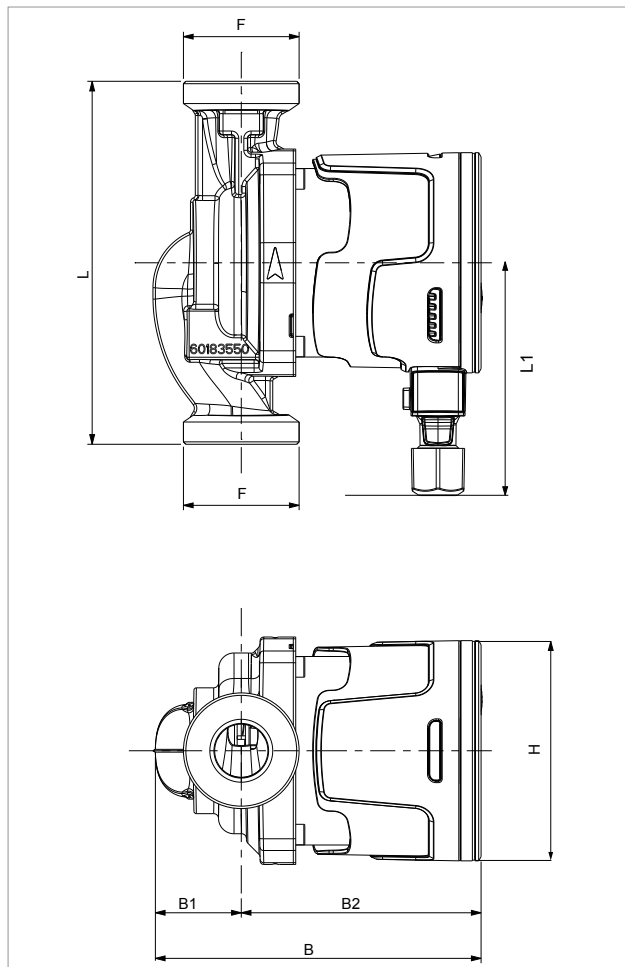

The performance curves are based on kinematic viscosity values = 1 mm²/s and density equal to 1000 kg/m³. Curve tolerance according to ISO 9906.

MODEL	Q=m³h	0	0,3	0,6	0,9	1,8	2,4	3	3,6
	Q=l/min	0	5	10	15	30	40	50	60
EVOSTA 2 40-70/150 SAN (1")	H (m)	6,9	6,9	5,8	5,1	3,4	2,4	1,6	0,8

MODEL	CENTRE DISTANCE mm	PUMP CONNECTIONS	POWER INPUT 50 Hz	P1 MAX W	In A	MINIMUM SUCTION PRESSURE	
						t°	90°
EVOSTA 2 40-70/150 SAN (1")	150	DN25 THREADED (G 1" ½)	1x230 V ~	35	0,043 - 0,32	m.c.w.	10

MODEL	L	L1	B	B1	B2	H	F	PACKING DIMENSIONS			VOLUME m³	WEIGHT Kg
								L	B	H		
EVOSTA 2 40-70/150 SAN (1")	150	96	134,6	35,5	99,1	91	1" ½	192	99	150	0,0028	2,16

EVOSTA 2 SAN - WET ROTOR ELECTRONIC CIRCULATORS

Pumped liquid temperature range: from -10 °C to +110 °C - Maximum operating pressure: 10 bar (1000 kPa)

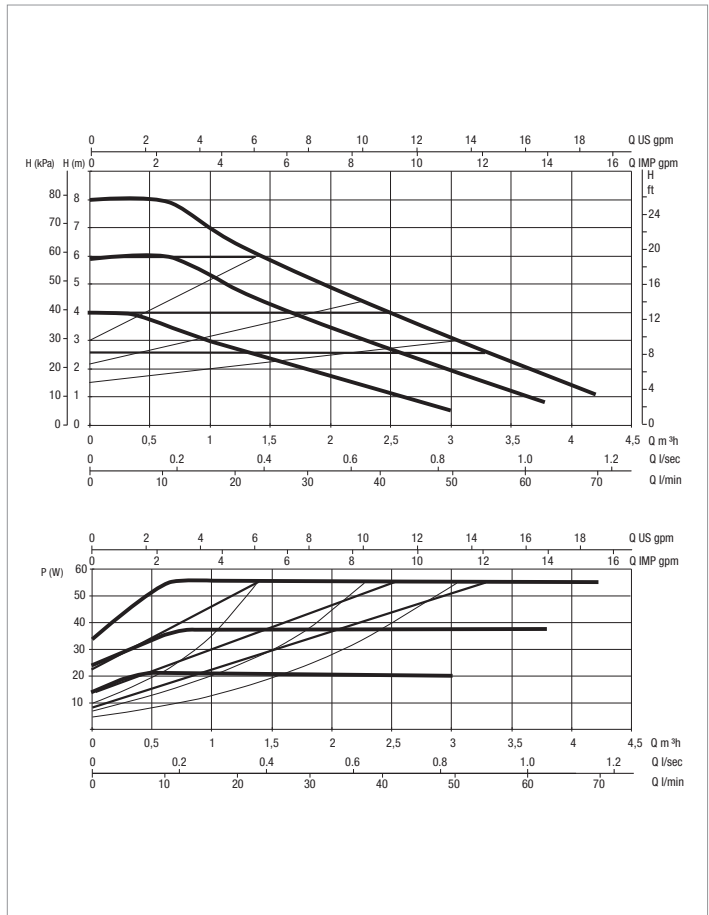
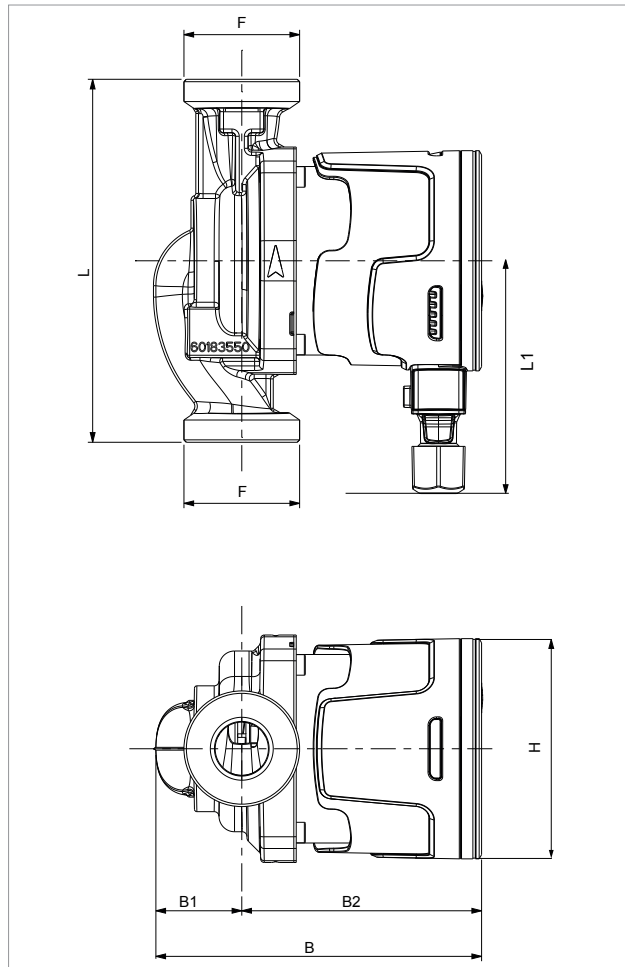

The performance curves are based on kinematic viscosity values = 1 mm²/s and density equal to 1000 kg/m³. Curve tolerance according to ISO 9906.

MODEL	Q=m³h	0,0	0,9	1,8	2,4	3,0	3,6	4,2
	Q=l/min	0	15	30	40	50	60	70
EVOSTA 2 80/150 SAN (1")	H (m)	8	7,2	5,4	4,2	3,2	2,1	1

MODEL	DISTANCE CENTRE mm	PUMP CONNECTIONS	POWER INPUT 50 Hz	P1 MAX W	In A	MINIMUM SUCTION PRESSURE	
						t°	90°
EVOSTA 2 80/150 SAN (1")	150	DN25 THREADED (G 1" ½)	1x230V ~	55	0,053 -0,47	m.c.w.	10

MODEL	L	L1	B	B1	B2	H	F	PACKING DIMENSIONS			VOLUME m³	WEIGHT Kg
								L	B	H		
EVOSTA 2 80/150 SAN (1")	150	96	134,6	35,5	99,1	91	1" ½	192	99	150	0,0028	2,16

EVOPLUS SMALL / EVOPLUS SMALL SAN

WET ROTOR ELECTRONIC CIRCULATORS



EVOPLUS SMALL



EVOPLUS SMALL SAN

TECHNICAL DATA

Operating range: from 2 a 12 m³/h with head of up to 11 metres.
Pumped liquid temperature range: from -10 °C to +110 °C.
Pumped liquid: clean, free of solids and mineral oils, non-viscous, chemically neutral, with properties similar to water. (glycol max 30%).
Maximum operating pressure: 16 bar (1600 kPa).
Standard flanges: DN 32, DN 40 PN 6 / PN 10 / PN 16 (4 holes).
Maximum ambient temperature: + 40 °C.
Minimum suction pressure: the values are shown in the corresponding tables.
Accessories: ½" F, ¾" F, 1" F, 1" ¼ F, 1" ¼ M union connectors. DN 32 PN 10 and DN 40 PN 10 threaded counter flanges.
Electromagnetic compatibility: EVOPLUS circulator comply with EN 61800-3 standard, category C2, as far as electromagnetic compatibility.
Electromagnetic emissions: Residential environment (containment measures might be required in some cases).
Conducted emissions: Residential environment (containment measures might be required in some cases).
Circulator protection class: IP 44.
Insulation class: F.
Standard voltage: single-phase 220-240 V, 50/60 Hz.
Sound pressure values: ≤ 33 dB(A).
Product compliant with European Standards EN 61800-3 – EN 60335-1 – EN 60335-2-51

APPLICATIONS

EVOPLUS circulation electronic pumps can be used in heating, ventilation, and air conditioning systems for residential and commercial buildings, like:

- Large residential buildings
- Condominiums and small apartment buildings
- Homes
- Real estate buildings
- Private and public hospitals
- Schools
- Office buildings

Single version available, with 1 ½" e 2" threaded ports, and with DN 32 and DN 40, PN 6 / PN 10 / PN 16 flanged ports.

Twin version available with DN 32 and DN 40, PN 6 / PN 10 / PN 16 flanged pump body.

Special version available with bronze pump body for the recirculation of sanitary water.

Possibility of 0-10 V or PWM external signal control, and connection to ModBus management systems (LonBus with appropriate additional communication module), with the use of the optional Multifunction module (supplied as standard for the twin version). **You can remotely control the single version thanks to the Dconnect service** (with Dconnect box supplied separately).

HEATING SYSTEM APPLICATIONS

The heating required for the different applications varies significantly during day and night, due to the external temperature, or the degree of occupancy inside the areas. To the above, one must add the different needs of the various environments, and the opening or closing of the various circuit branches of complex systems. Electronic wet rotor pumps ensure at all times, and virtually in all correctly sized systems, a sufficient level of energy, together with a quieter operation, and more comfort, together with an important reduction of operating costs.

AIR CONDITIONING APPLICATIONS

Unlike conventional electronic pumps, EVOPLUS electronic circulators can be used also in air conditioning systems where the temperature of the pumped liquid is lower than the room temperature. In these conditions, condensation tends to form on the outer surface of the circulator, which however does not affect the operation of the electronic and the mechanical components. The unit is designed and sized in such a way that it allows condensation to drain without damage to the construction components.

SANITARY RECIRCULATION APPLICATIONS

The SAN version, with bronze pump body, was specifically developed for the recirculation of sanitary water. With the constant temperature mode of operation, the temperature inside the recirculation piping is controlled without the need for thermostat valves, therefore optimizing comfort.

CONSTRUCTION FEATURES

Monobloc circulation pump consisting of the cast iron hydraulic section, and the wet rotor synchronous motor. Aluminium motor casing. Scroll type pump body featuring high hydraulic efficiency thanks to highly precise design and smooth internal surfaces. In-line suction and delivery ports. The single version is supplied as standard with insulating casing, to avoid heat dispersion and/or the formation of condensation on the pump body. For the twin version, the insulation must be provided by the installer. In any case, pay attention not to obstruct the condensation drainage ducts, to avoid impairing the operation of the circulator. The EVOPLUS circulators for small collective systems are connected to the power input line using a practical connector with plug supplied as standard, which makes the operation quick and easy. Technopolymer impeller, aluminium motor shaft on graphite bushings lubricated by the pumped liquid. Stainless steel rotor protection liner. Ceramic thrust ring, ethylene-propylene seal rings and carbon fibre composite stator liner. Asynchronous motor with permanent magnet rotor. The twin version features an automatic swing check valve incorporated in the delivery port, to avoid water recirculating through the unit when this is not running; in addition, a blank flange is also supplied as standard, to allow either of the two motors to be removed for servicing. PN 16 standard pump body execution, flanged with 4 holes, compatible with PN 6 / PN 10 / PN 16 counter flanges, to ensure the interchangeability of the pumps in existing systems.

DCONNECT SERVICE

REMOTE CONTROL FOR ELECTRONIC RESIDENTIAL AND COMMERCIAL SYSTEMS

The Dconnect service offers simple and intuitive remote control of your installation, without the need of a server or specialist personnel.

With Dconnect, you can remotely manage your installations as if you were right in front of them.

Thanks to the system operation charts, you will also be able to optimise operation. You will also receive prompt notifications of any system faults.

THE CONNECTIVITY SERVICE ALLOWS YOU TO:

EASILY MONITOR YOUR SYSTEMS

The installations with green status are OK, while the orange ones need attention, and the red ones are experiencing problems

DCONNECT

Installation list

Impianto di pressurizzazione via Cairoli Pisa STATUS ✔	Condominio Cancelli Palala STATUS ⚠	Condominio Pero Livorno STATUS ✔	Condominio Nicolai Firenze STATUS ✔
Officine Arnoldi Pressurizzazione STATUS ✔	Officine Arnoldi Riscaldamento STATUS ✔	Officine Arnoldi Acqua Calda Sanitaria STATUS ✔	Officine Arnoldi gruppi frigo STATUS ✔

TAKE ANY NECESSARY ACTIONS AS IF YOU WERE RIGHT IN THE PUMP ROOM

Using the internet site or the APPs, you will be able to easily and quickly control your systems.

DCONNECT

NAME : **EVOPLUS SMALL**
 PRODUCT DESCRIPTION : **EVOPLUS SMALL**
 SERIAL : RRAYM

Time elapsed from last received data **less than 3m**

Status

SYSTEM ERROR STATUS System OK	HEAD 1.2 m	PUMP STATUS Run	ESTIMATED FLOW 0.8 m³/h
POWER 9 W	RPM 1510 rpm	CURRENT 110 mA	RUN TIME PUMP - h
BOARD TEMPERATURE - °C	LIQUID TEMPERATURE - °C	LIQUID TEMPERATURE 2 - °C	HEATSINK TEMPERATURE - °C
LINE VOLTAGE 228 V			

DCONNECT SERVICE

REMOTE CONTROL FOR ELECTRONIC RESIDENTIAL AND COMMERCIAL SYSTEMS

In order to use the Dconnect service, registration and connected products are required.

Connect to the website: <https://dconnect.dabpumps.com>, using Internet Browsers such as Microsoft Edge or Google Chrome.

The Android and iOS Dconnect APPs can be downloaded from the relevant Stores:



REMOTE ALARMS

In case of alarm, the Dconnect service will promptly send you a notification, so that you can check what is happening and organise a visit to the system before the issue becomes an emergency for your customer.

WHAT PRODUCTS CAN YOU MANAGE USING THE DCONNECT SERVICE?

MCE/P, MCE/C, ADAC, Active driver Plus, Ebox, Evoplus, Esybox, Esybox mini, Esybox Diver, Dtron 3.

WHAT DO YOU NEED TO USE THE SERVICE?

1. DConnect Box
2. Cables for the connection of the DConnect Box / Dconnect Box 2 to the products to control
3. One or more compatible products
4. An internet connection in the system to control

For more information visit: internetofpumps.com

EVOPLUS SMALL / EVOPLUS SMALL SAN

WET ROTOR ELECTRONIC CIRCULATORS

EVOPLUS CONSTRUCTION CHARACTERISTICS FOR SMALL COLLECTIVE SYSTEMS (ELECTRONIC DEVICE).

EVOPLUS circulators are controlled by a latest generation NPT technology IGBT device, for better efficiency and strength. The specific features are:

- Sensorless motor control
- Sine-wave PWM modulation
- High carrier frequency, to eliminate all audio band noise
- dedicated 32 bit processor
- Optimised "space vector" algorithm

An intuitive and functional user interface guarantees ease of calibration by all users. The easy to read OLED display on the control panel, 4 simple navigation keys, an in-line cascade menu featuring the latest mobile technology trends, and a wide range of functions, mean that EVOPLUS circulators are truly revolutionary products. A reliable and sturdy construction, together with a modern and innovative design, complete the product, also in terms of aesthetic value. This range is ready for the following remote commands through expansion modules:

Base Module

- Economy mode
- Circulator start/stop
- Presence/absence of system alarms
- Pump in operation notification

Multifunction Module*

- 2 x 0-10 V analogue signals
- 1 PWM signal
- 1 ΔT analogue signal from temperature sensor
- Connection to ModBus system management devices
- Optional LonBus with appropriate module
- Presence/absence of system alarms
- Pump in operation notification

* Inputs available only if the associated function is active

MATERIALS

N.	PARTS	MATERIALS
1	PUMP BODY	CAST IRON 250 UNI ISO 185 - CTF BRONZE (for the SAN version)
4	IMPELLER	TECHNOPOLYMER
7A	MOTOR SHAFT	ALLUMINA
7B	ROTOR	STAINLESS STEEL LINER
8	STATOR	-
10	MOTOR CASING	DIE-CAST ALUMINIUM
127	SEAL RING	EPDM RUBBER
128	STATOR LINER	STAINLESS STEEL
130	CLOSING FLANGE	STAINLESS STEEL
131	THRUST RING SUPPORT	EPDM RUBBER
132	BUSHINGS	GRAPHITE

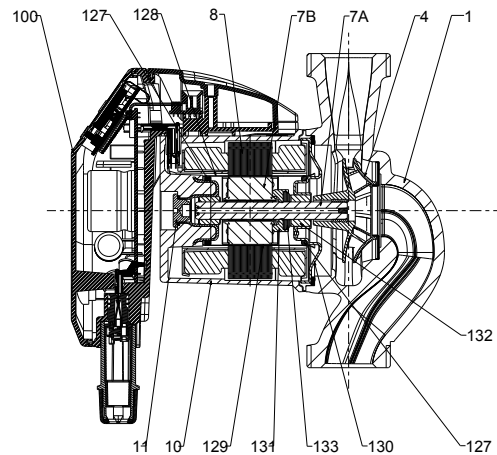

- Legend: (example)

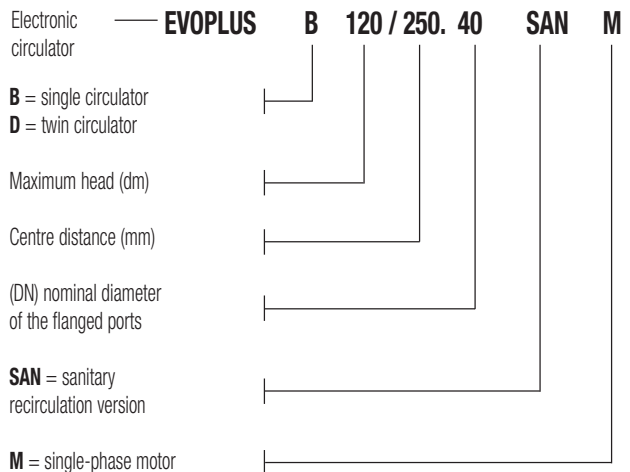
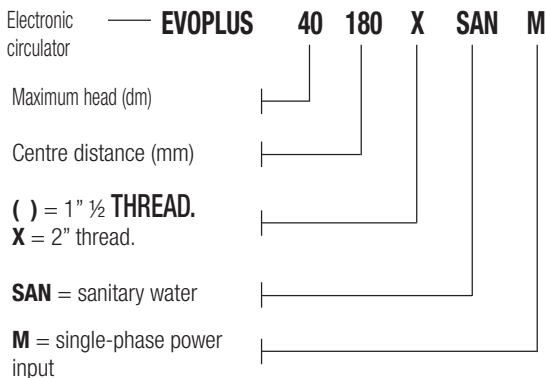

EVOPLUS SMALL / EVOPLUS SMALL SAN

WET ROTOR ELECTRONIC CIRCULATORS

MODES OF OPERATION

All the functions listed below can be consulted by the users (including less experienced ones) by simply scrolling through the menu. The calibration and the modification of the parameters are protected, and can only be completed by expert users. The factory settings of the EVOPLUS range are for proportional differential pressure control mode in the curve that ensures the best energy efficiency index (EEI).

1 - $\Delta P-v$ proportional differential pressure adjustment mode

With $\Delta P-v$ adjustment mode, with the variation of the flow rate, the value of the delivery of the head also varies in a linear manner, from H_{setp} to $H_{setp}/2$.

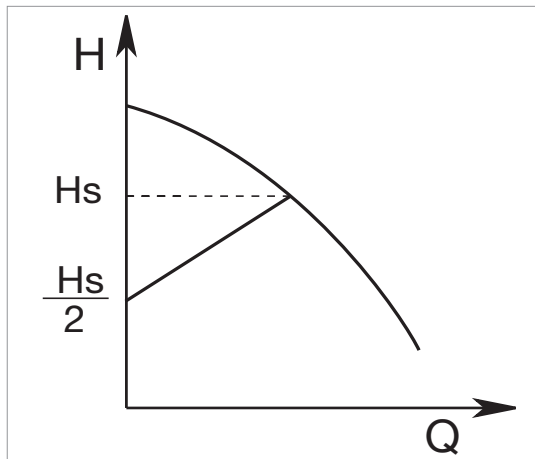

This adjustment is particularly indicated for the following systems:

a. Two-pipe heating systems with thermostat valves and with:

- head greater than 4 metres;
- very long circuit piping;
- valves with wide operating range;
- differential pressure regulators;
- high pressure drops in those parts of the system carrying the entirety of the water flow rate;
- low differential pressure.

b. Under-floor central heating systems with thermostatic valves and significant pressure drops in the boiler circuit.

c. Systems with primary circuit pumps with high pressure drops.

Example of set-up of the set-point with $\Delta P-v$

The following operating point is required:

$$Q = 6,5 \text{ m}^3/\text{h}$$

$$H = 6 \text{ m}$$

PROCEDURE:

1. In the graph, find the desired operating point, and then find the EVOPLUS curve closest to it (in this case the point lies precisely on the curve)
2. Follow the curve upwards until reaching the intersection with the limit curve of the circulator.
3. The head reading found at this limit point is the set-point head that must be entered to obtain the desired operating point.

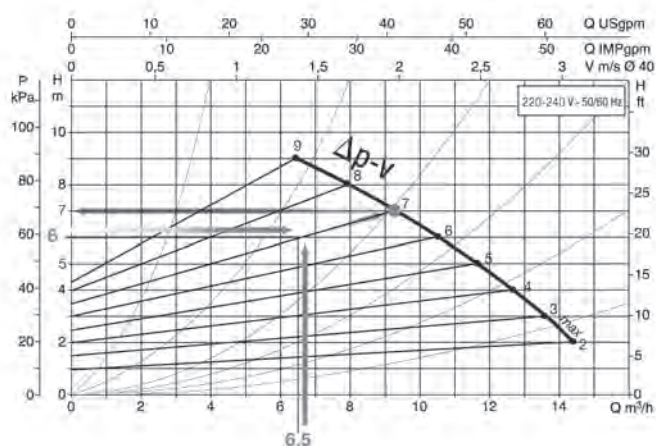

2 - $\Delta P-c$ constant differential pressure adjustment mode

The $\Delta P-c$ adjustment mode keeps the differential pressure of the system constantly at the H_{setp} value set, even in case of variation of the flow rate.

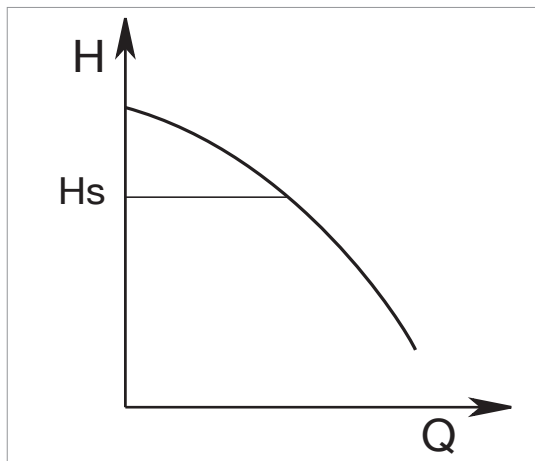

This adjustment is particularly indicated for the following systems:

a. Two-pipe heating systems with thermostat valves and with:

- head lower than 2 metres;
- natural circulation;
- low pressure drops in those parts of the system carrying the entirety of the water flow rate;
- high differential temperature (central heating).

b. underfloor heating systems with thermostat valves

c. single-pipe heating systems with thermostat valves and calibration valves

d. Systems with primary circuit pumps with low pressure drops.

EVOPLUS SMALL / EVOPLUS SMALL SAN

WET ROTOR ELECTRONIC CIRCULATORS

3 - Constant curve adjustment modes

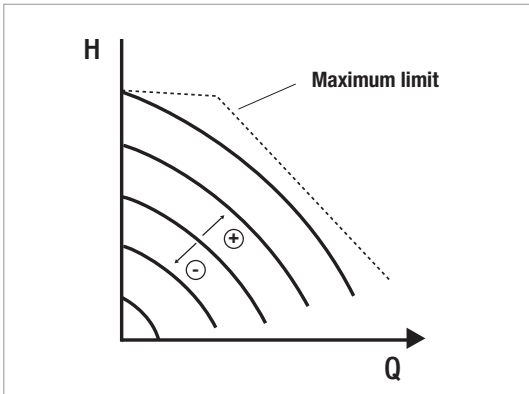

In this control mode, the circulator works based on constant speed characteristic curves. The operation curve is selected by setting the rotation speed using a percentage factor. The 100 % value indicates the maximum limit curve. The actual rotation speed may be affected by the power and differential pressure limitations of the actual circulator model. The rotation speed may be set using the display, or either a 0-10 V or PWM external signal, using the appropriate multifunction module.

Control mode indicated for constant flow rate heating and air conditioning systems.

4 - Constant differential pressure control mode with proportional control based on the water temperature (Function available with multifunction module)

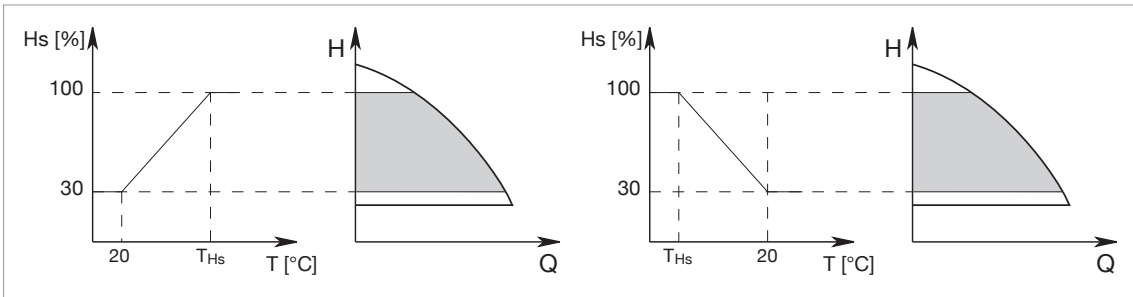

The circulator head set-point is reduced in accordance with the water temperature. The liquid temperature can be set between 0 °C to 100 °C.

This adjustment is particularly indicated for the following systems:

- in variable flow rate systems (two-pipe central heating systems), in which a further reduction of circulator performance is provided in line with the lowering of the temperature of the circulating liquid, in case of reduced heating demand.
- in constant flow rate systems (single-pipe and under-floor central heating systems), where the performance of the circulator can only be adjusted by activating the temperature influence function. It is set through the EVOPLUS control panel.

5 - ΔT -c constant differential pressure control mode (Function available with multifunction mode) *

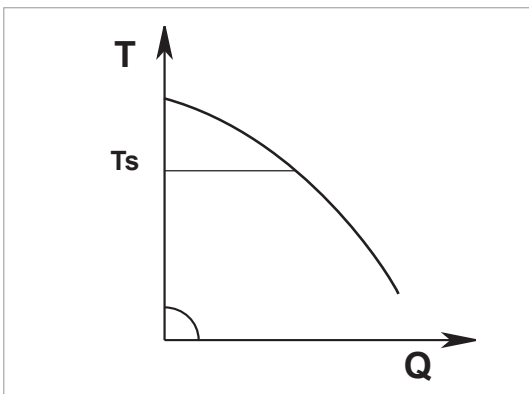

The ΔT -c control mode keeps the pumped liquid at constant temperature, changing the flow rate to the Tsetp settable value.

This adjustment is particularly indicated for the following systems:

- Under-floor heating systems.
- systems with primary circuit pumps.
- Systems with circuit pumps with heat exchanger.
- Solar energy systems with storage tanks.
- Solar panel swimming pool heating systems.

* Adjustment during implementation.

ECONOMY MODE

The economy function can be set directly on the control panel, by setting a reduction value (f.rid), the maximum value of which can be 50%. In all the previously listed settings, the Hset value must be replaced with an Hset x f.rid.

EVOPLUS SMALL / EVOPLUS SMALL SAN

WET ROTOR ELECTRONIC CIRCULATORS

BASE MODULE

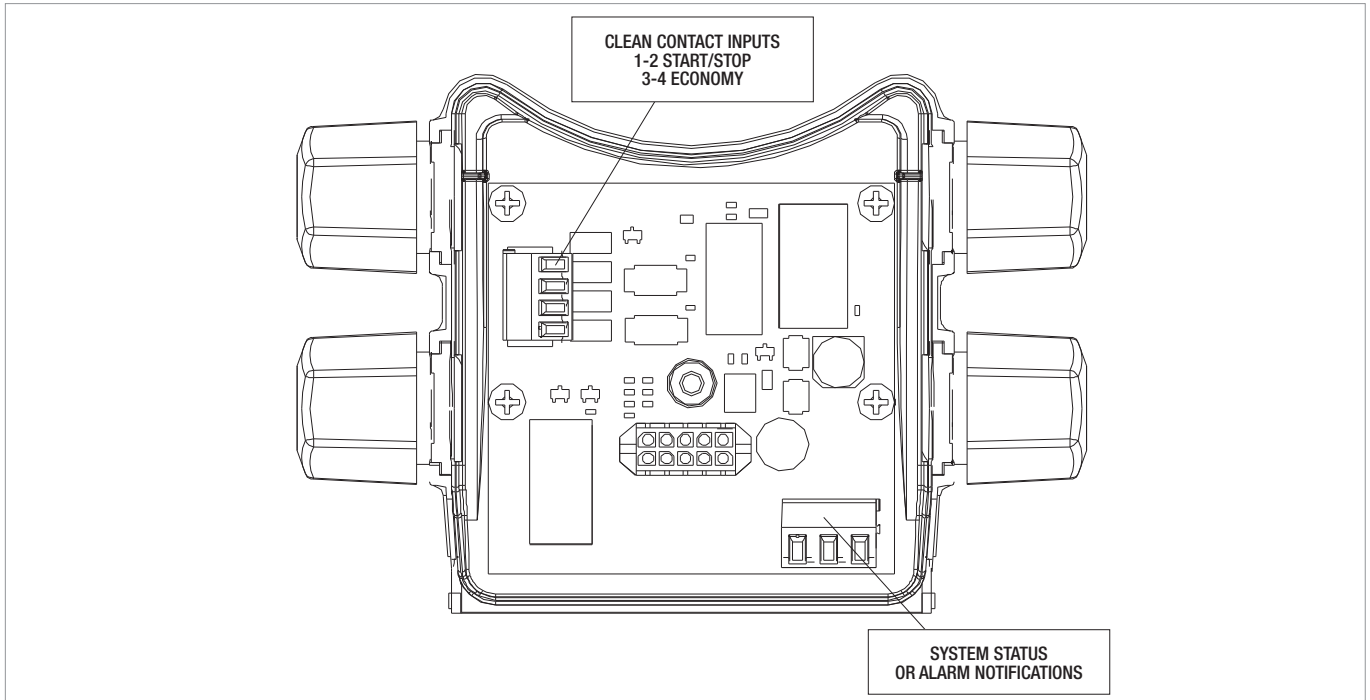

Digital inputs

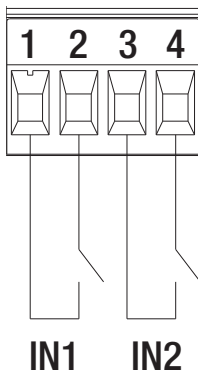

Clean contact inputs
1-2 START/STOP
3-4 ECONOMY

Input	Terminal no.	Type of contact	Associated function
IN1	1	Clean contact	EXT: If it is activated from the control panel, it will be possible to remotely control the switching on and off of the pump.
	2		
IN2	3	Clean contact	Economy: If it is activated from the control panel, it will be possible to remotely activate the set-point reduction function.
	4		

If the **EXT** and **Economy** functions have been activated using the control panel, the system will behave as follows:

IN1	IN2	System status
Open	Open	Pump stopped
Open	Close	Pump stopped
Close	Open	Pump in operation with set-point set by the user
Close	Close	Pump in operation with reduced set-point

Digital outputs

System status or alarm notifications

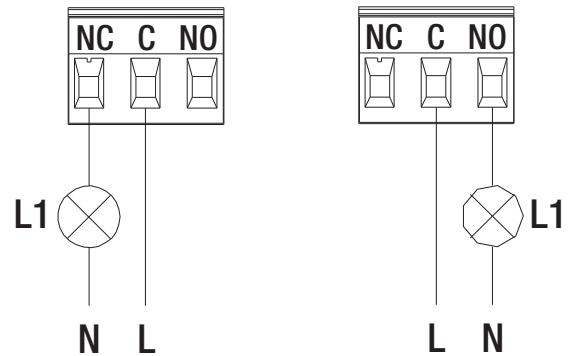

The function associated to OUT1 is "Alarms Present"; L1 turns on when a system alarm is present, and turns off when no fault is detected.

The function associated with OUT1 is "Pump Status"; L1 turns on when the pump is in operation, and stops when the pump is idle.

Output	Terminal no.	Type of contact	Associated function
OUT1	NC	NC	<ul style="list-style-type: none"> • Presence/absence of system alarms • Pump in operation/Pump stopped
	C	COM	
	NO	NO	

The OUT1 output is available on the 3-pole removable terminal box, where the type of contact is also shown (NC = Normally Closed, COM = Common, NO = Normally Open).

Characteristics of the output contacts	
Max sustainable voltage [V]	250
Max sustainable current [A]	5 - If resistive load 2,5 - If inductive load
Max cable section accepted [mm ²]	1,5

EVOPLUS SMALL / EVOPLUS SMALL SAN

WET ROTOR ELECTRONIC CIRCULATORS

MULTIFUNCTION MODULE

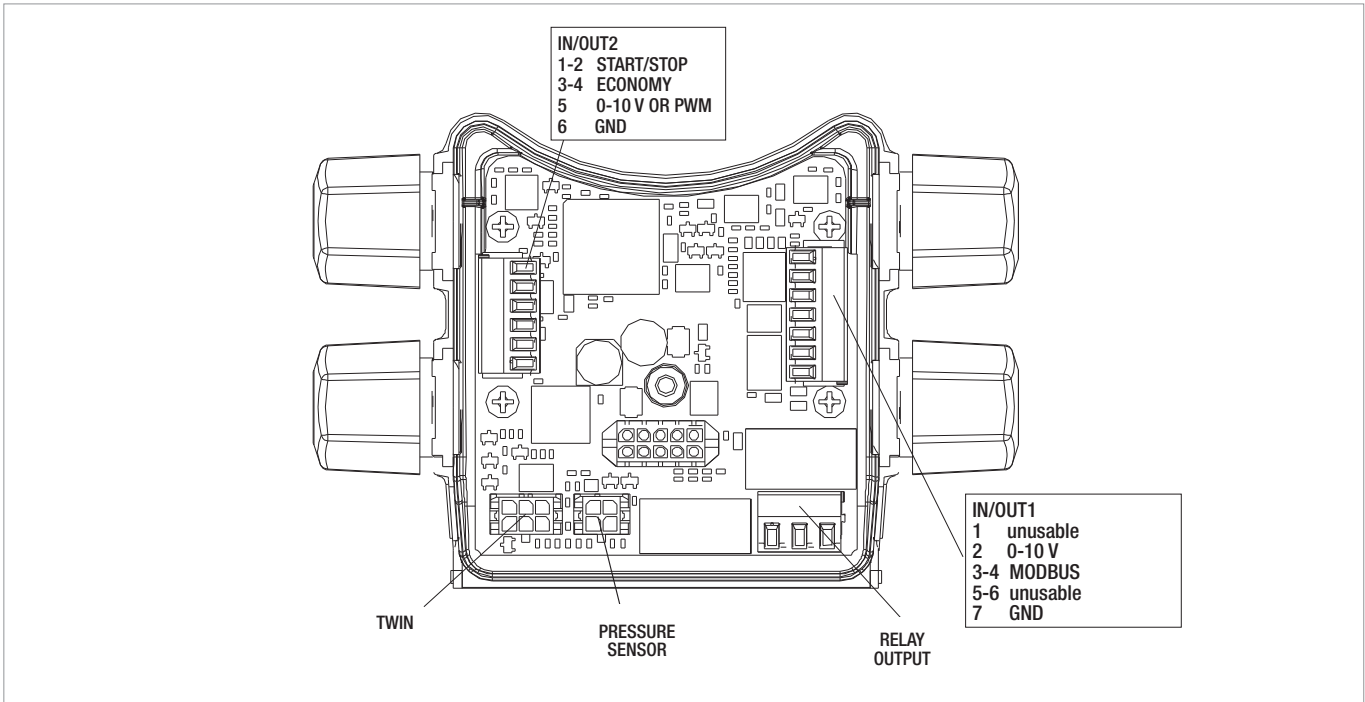

Digital inputs

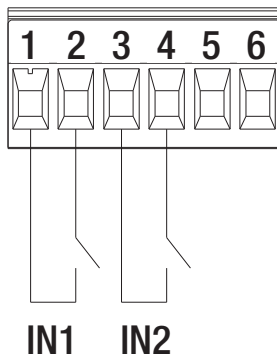

IN/OUT2
 1-2 START/STOP
 3-4 ECONOMY
 5 0-10V, PWM and NTC
 6 GND

Input	Terminal no.	Type of contact	Associated function
IN1	1	Clean contact	EXT: If it is activated from the control panel, it will be possible to remotely control the switching on and off of the pump.
	2		
IN2	3	Clean contact	Economy: If it is activated from the control panel, it will be possible to remotely activate the set-point reduction function.
	4		

If the **EXT** and **Economy** functions have been activated using the control panel, the system will behave as follows:

IN1	IN2	System status
Open	Open	Pump stopped
Open	Close	Pump stopped
Close	Open	Pump in operation with set-point set by the user
Close	Close	Pump in operation with reduced set-point

MODBUS

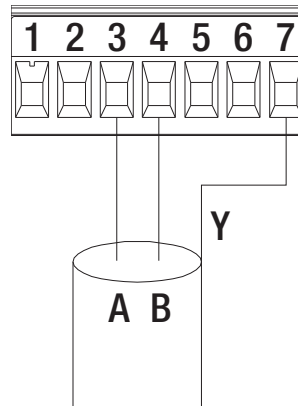

IN/OUT1
 1 unusable
 2 0-10 V
 3-4 modbus
 5-6 unusable
 7 GND

The multifunction expansion module provides serial communication through an RS-485 input. The communication is established in accordance with the MODBUS specifications.

Using the MODBUS, it is possible to remotely set the circulator operating parameters, like the desired differential pressure, the control mode, etc. At the same time, the circulator can provide important information on the status of the system.

Modbus terminals	Terminal no.	Description
A	3	Terminal not inverted (+)
B	4	Terminal inverted (+)
Y	7	GND

LONBUS

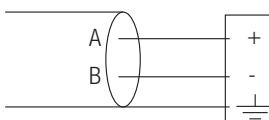

Gateway/ Evoplus connection

Using some modules available on the market, the circulator, and therefore its status, can also be made available to a LonWorks network. It will then be possible to change the parameters of the circulator by reading and amending the registers as indicated in the "Modbus Protocol instruction manual", available at the following address: "<http://www.dabpumps.it/evoplus>".

EVOPLUS SMALL / EVOPLUS SMALL SAN

WET ROTOR ELECTRONIC CIRCULATORS

PWM AND NTC ANALOGUE INPUT

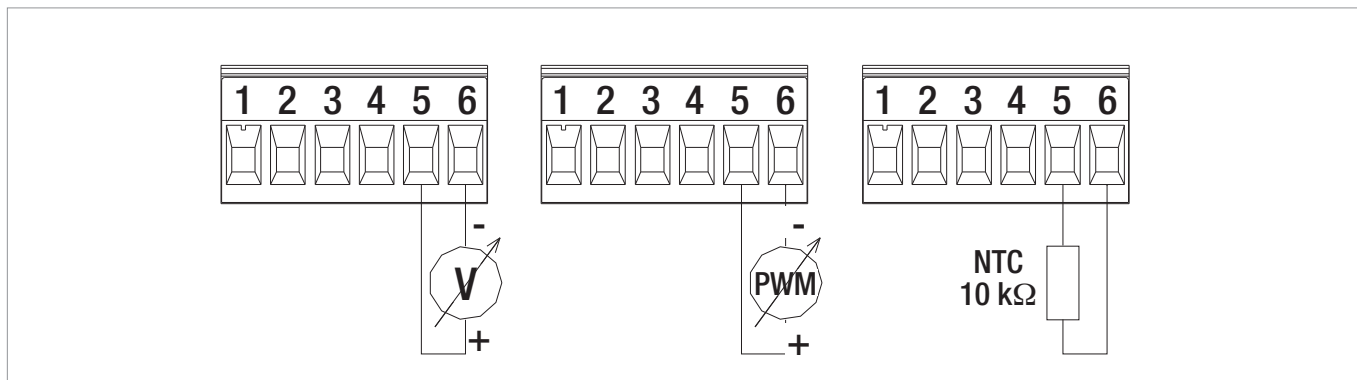

DIGITAL OUTPUTS

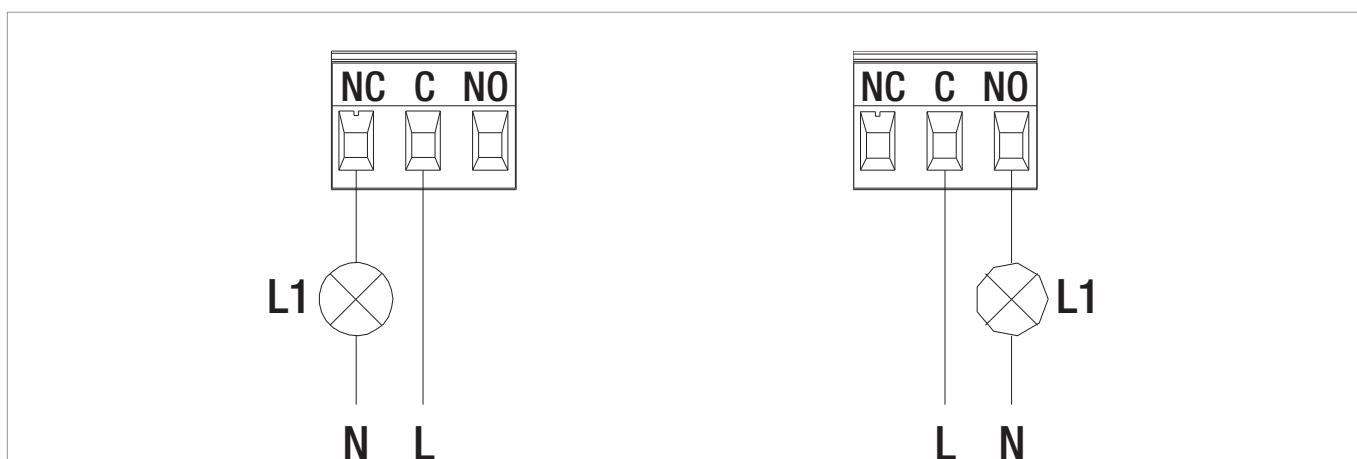

The function associated with OUT1 is "Pump Status"; L1 turns on when the pump is in operation, and stops when the pump is idle.

The function associated to OUT1 is "Alarms Present"; L1 turns on when a system alarm is present, and turns off when no fault is detected.

Output	Terminal no.	Type of contact	Associated function
OUT1	NC	NC	<ul style="list-style-type: none"> • Presence/absence of system alarms • Pump in operation/Pump stopped
	C	COM	
	NO	NO	

The OUT1 output is available on the 3-pole removable terminal box, where the type of contact is also shown (NC = Normally Closed, COM = Common, NO = Normally Open).

Characteristics of the output contacts	
Max sustainable voltage [V]	250
Max sustainable current [A]	5 - If resistive load 2,5 - If inductive load
Max cable section accepted [mm ²]	1,5

EVOPLUS RANGE

WET ROTOR ELECTRONIC CIRCULATORS

PERFORMANCE RANGE

The performance curves are based on kinematic viscosity values = 1 mm²/s and density equal to 1000 kg/m³. Curve tolerance according to ISO 9906.

GRAPHIC SELECTION TABLE

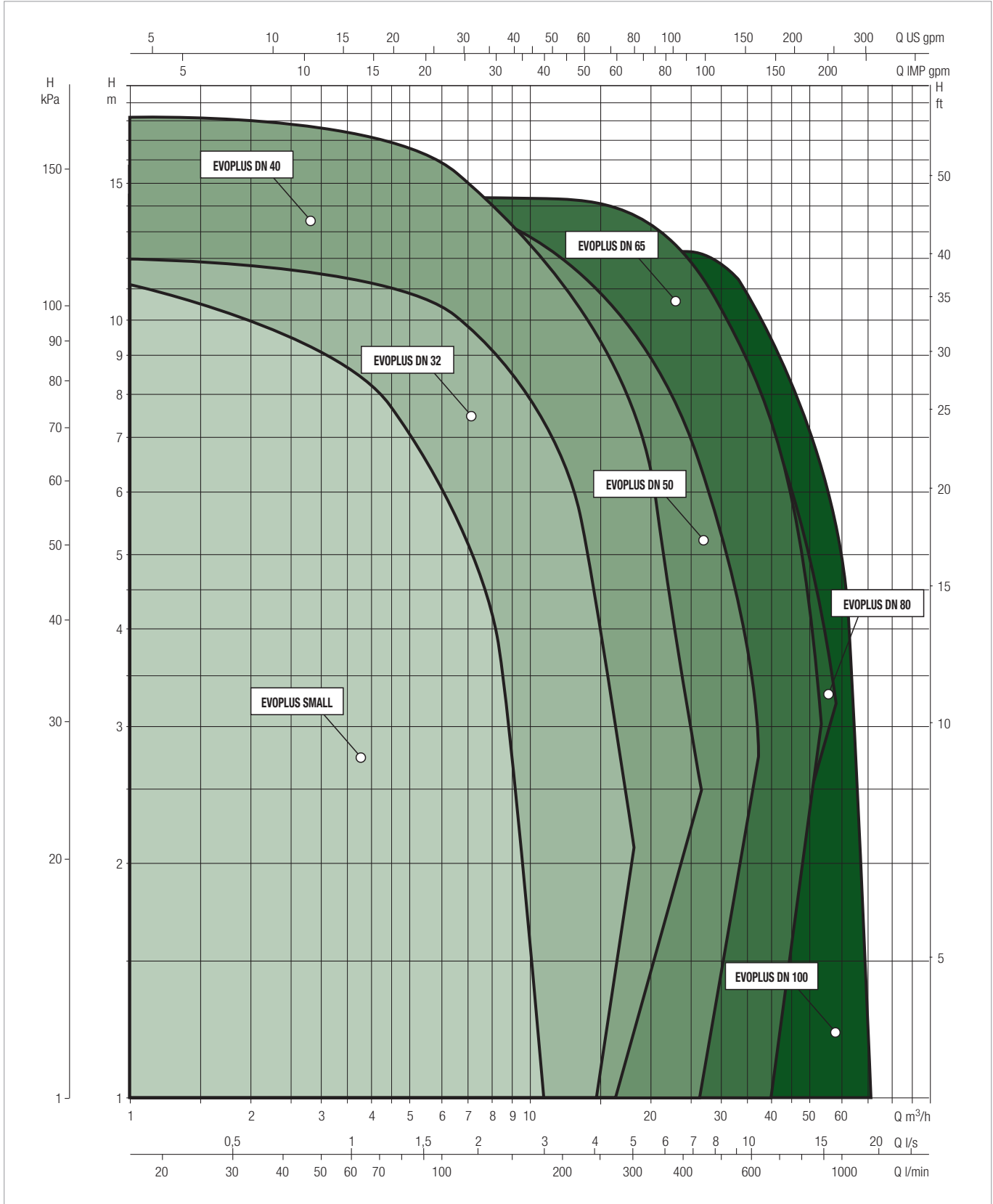

EVOPLUS SMALL / EVOPLUS SMALL SAN

WET ROTOR ELECTRONIC CIRCULATORS

WET ROTOR ELECTRONIC CIRCULATORS

SELECTION TABLE - EVOPLUS SMALL

MODEL	Q=m ³ h	0	2,4	3	4,2	5,4	7,2	9,6
	Q=l/min	0	40	50	70	90	120	160
EVOPLUS 40/180 M	H (m)	4,2	4,2	4	3,1	2,4		
EVOPLUS 60/180 M		6,1	6,1	5,8	4,6	3,4		
EVOPLUS 80/180 M		8,2	8,2	7,7	6,2	4,8	2,9	
EVOPLUS 110/180 M		11,1	10,1	9,2	7,5	5,9	3,9	
EVOPLUS 40/180 XM		4,1	4,1	4	3,1	2,2		
EVOPLUS 60/180 XM		6,1	6,1	5,7	4,5	3,4		
EVOPLUS 80/180 XM		8,1	8,1	7,6	6,2	4,9	3	
EVOPLUS 110/180 XM		11,3	10,2	9,5	7,9	6,3	4,3	2
EVOPLUS B 40/220.32 M		4,2	4,2	4,2	3,3	2,5	1,3	
EVOPLUS B 60/220.32 M		6,1	6,1	5,6	4,6	3,6	2,2	
EVOPLUS B 80/220.32 M		8	8	7,3	6	4,9	3,3	
EVOPLUS B 110/220.32 M		11,2	10,5	9,6	8,1	6,8	5	2,6
EVOPLUS B 40/250.40 M		4,2	4,2	4,2	3,3	2,5	1,3	
EVOPLUS B 60/250.40 M		6,1	6,1	5,6	4,6	3,6	2,2	
EVOPLUS B 80/250.40 M		8	8	7,3	6	4,9	3,3	
EVOPLUS B 110/250.40 M		11,2	10,5	9,6	8,1	6,8	5	2,6
EVOPLUS D 40/220.32 M		4,2	4,2	4,2	3,3	2,5	1,3	
EVOPLUS D 60/220.32 M		6,1	6,1	5,6	4,6	3,6	2,2	
EVOPLUS D 80/220.32 M		8	8	7,3	6	4,9	3,3	
EVOPLUS D 110/220.32 M		11,2	10,5	9,6	8,1	6,8	5	2,6
EVOPLUS D 40/250.40 M		4,2	4,2	4,2	3,3	2,5	1,3	
EVOPLUS D 60/250.40 M		6,1	6,1	5,6	4,6	3,6	2,2	
EVOPLUS D 80/250.40 M		8	8	7,3	6	4,9	3,3	
EVOPLUS D 110/250.40 M		11,2	10,5	9,6	8,1	6,8	5	2,6

SELECTION TABLE - EVOPLUS SMALL SAN

MODEL	Q=m ³ h	0	2,4	3	4,2	5,4	7,2	9,6
	Q=l/min	0	40	50	70	90	120	160
EVOPLUS 40/180 SAN M	H (m)	4,2	4,2	4	3,1	2,4		
EVOPLUS 60/180 SAN M		6,1	6,1	5,8	4,6	3,4		
EVOPLUS 80/180 SAN M		8,2	8,2	7,7	6,2	4,8	2,9	
EVOPLUS 110/180 SAN M		11,1	10,1	9,2	7,5	5,9	3,9	
EVOPLUS B 40/220.32 SAN M		4,2	4,2	4,2	3,3	2,5	1,3	
EVOPLUS B 60/220.32 SAN M		6,1	6,1	5,6	4,6	3,6	2,2	
EVOPLUS B 80/220.32 SAN M		8	8	7,3	6	4,9	3,3	
EVOPLUS B 110/220.32 SAN M		11,2	10,5	9,6	8,1	6,8	5	2,6
EVOPLUS B 40/250.40 SAN M		4,2	4,2	4,2	3,3	2,5	1,3	
EVOPLUS B 60/250.40 SAN M		6,1	6,1	5,6	4,6	3,6	2,2	
EVOPLUS B 80/250.40 SAN M		8	8	7,3	6	4,9	3,3	
EVOPLUS B 110/250.40 SAN M		11,2	10,5	9,6	8,1	6,8	5	2,6

EVOPLUS SMALL - WET ROTOR ELECTRONIC CIRCULATORS

Pumped liquid temperature range: from -10 °C to +110 °C - Maximum operating pressure: 16 bar (1600 kPa)

EVOPLUS 40/180 M

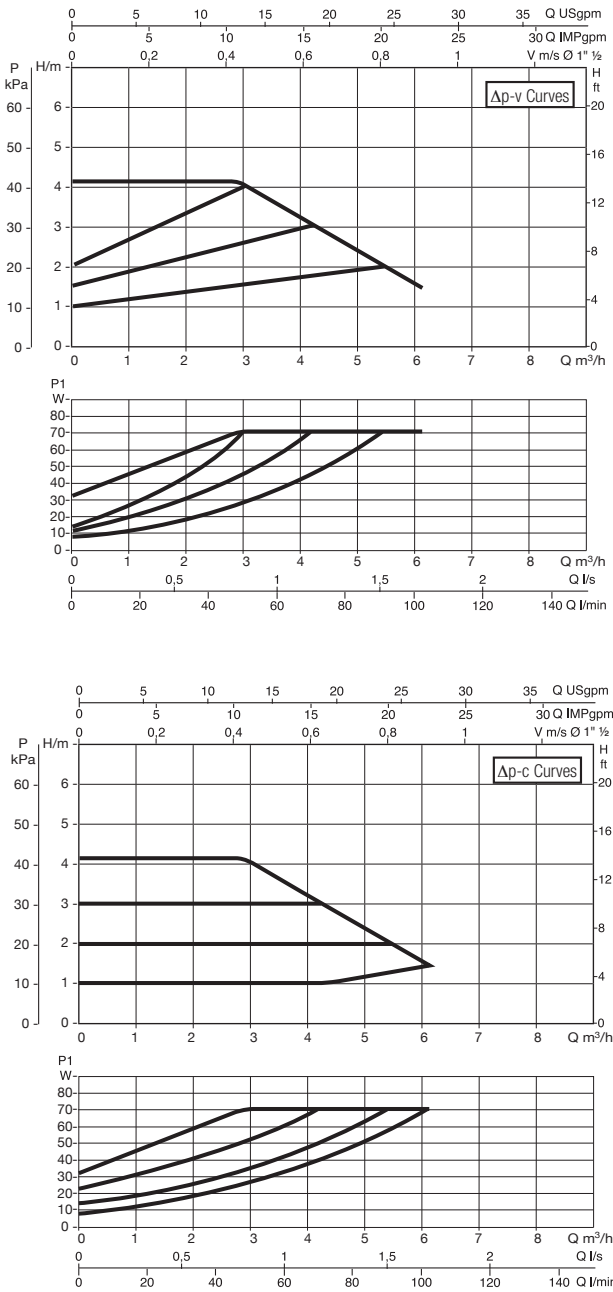

EVOPLUS 60/180 M

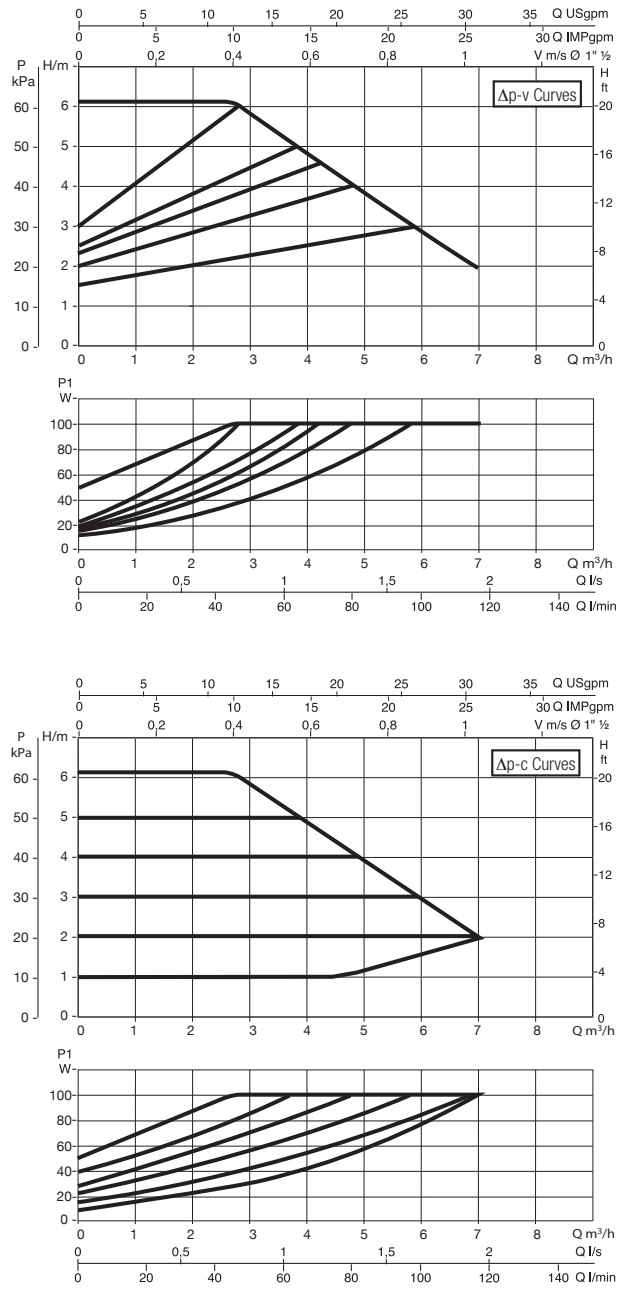

The curves are based on kinematic viscosity values = 1 mm²/s and density equal to 1000 kg/m³. Curve tolerance according to ISO 9906. Fixed speed curves available on the DNA.

MODEL	CENTRE DISTANCE mm	UNIONS ON REQUEST		COUNTERFLANGES ON REQUEST	POWER INPUT 50/60 Hz	P1 MAX W	In A	EEI*	MINIMUM SUCTION PRESSURE			WEIGHT Kg
		STANDARDISED	SPECIAL						t°	90°	100°	
EVOPLUS 40/180 M	180	1" F	¾" F - 1¼" M	-	220/240 V	68	0,52	EEI ≤ 0,20	m.c.w.	20	25	4,5
EVOPLUS 60/180 M	180	1" F	¾" F - 1¼" M	-	220/240 V	100	0,72	EEI ≤ 0,20	m.c.w.	20	25	4,5

The parameter of reference for the more efficient circulators is EEI ≤ 0,20.

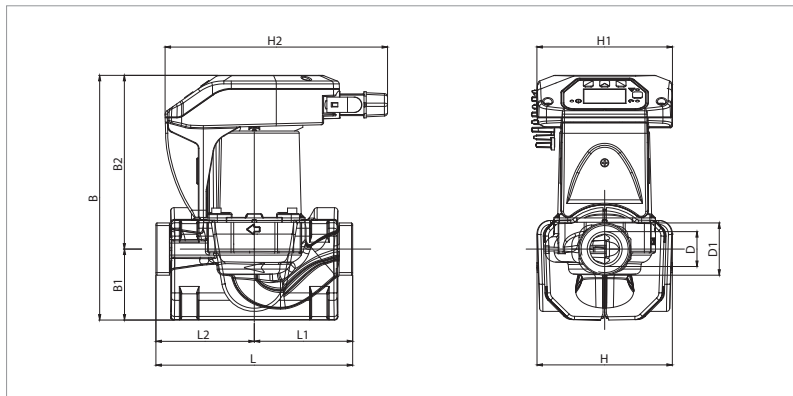

L	L1	L2	B	B1	B2
180	90	90	224	65	159

D	D1	H	H1	H2
32	1½"	124	124	204

EVOPLUS SMALL - WET ROTOR ELECTRONIC CIRCULATORS

Pumped liquid temperature range: from -10 °C to +110 °C - Maximum operating pressure: 16 bar (1600 kPa)

EVOPLUS 80/180 M

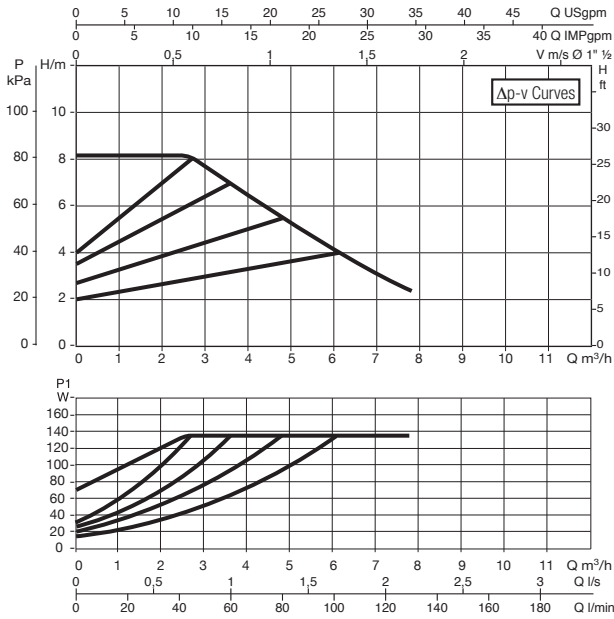

EVOPLUS 110/180 M

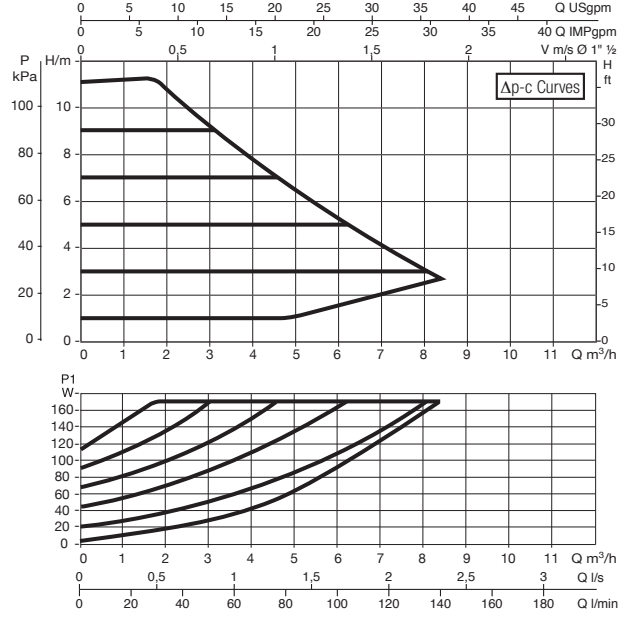
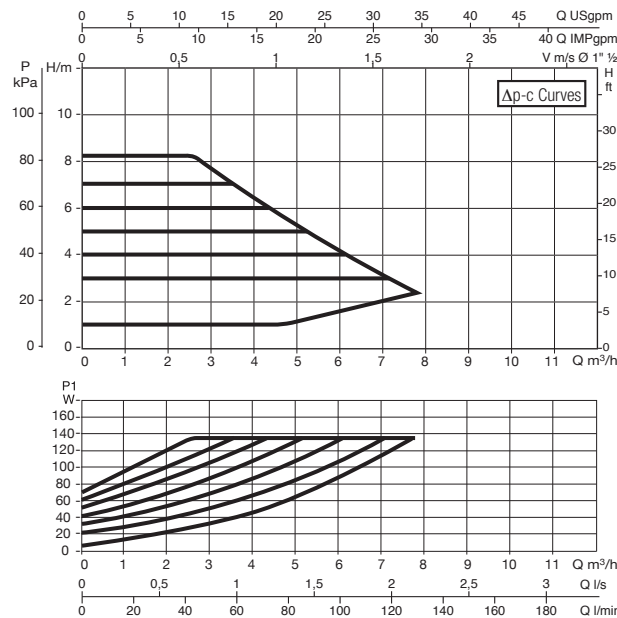
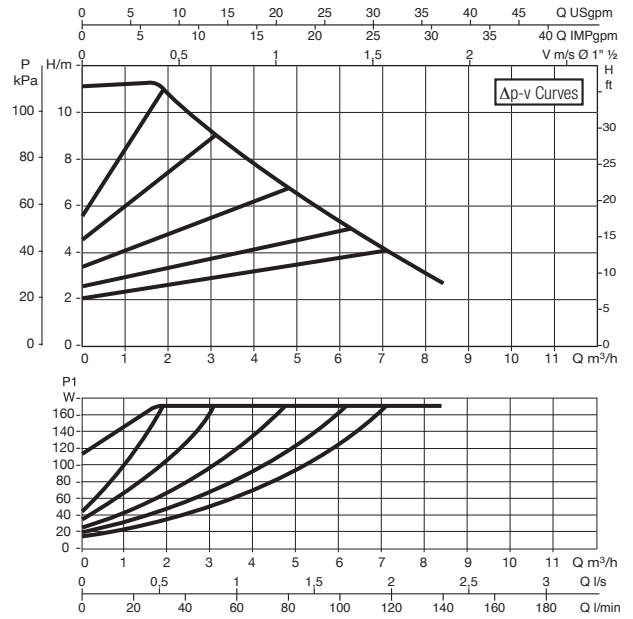

The curves are based on kinematic viscosity values = 1 mm²/s and density equal to 1000 kg/m³. Curve tolerance according to ISO 9906. Fixed speed curves available on the DNA.

MODEL	CENTRE DISTANCE mm	UNIONS ON REQUEST		COUNTERFLANGES ON REQUEST	POWER INPUT 50/60 Hz	P1 MAX W	In A	EEI*	MINIMU SUCTION PRESSURE			WEIGHT Kg
		STANDARDIZED	SPECIAL						t°	90°	100°	
EVOPLUS 80/180 M	180	1" F	¾" F - 1¼" M	-	220/240 V	130	0,95	EEI ≤ 0,20	m.c.w.	20	25	4,5
EVOPLUS 110/180 M	180	1" F	¾" F - 1¼" M	-	220/240 V	170	1,18	EEI ≤ 0,20	m.c.w.	20	25	4,5

The parameter of reference for the more efficient circulators is EEI ≤ 0,20.

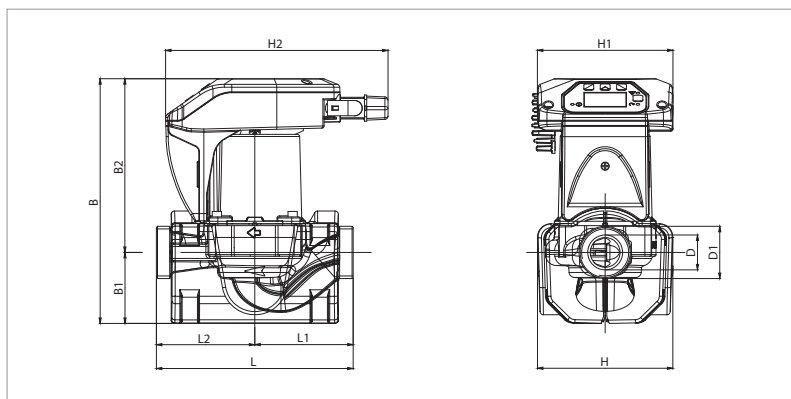

L	L1	L2	B	B1	B2
180	90	90	224	65	159

D	D1	H	H1	H2
32	1½"	124	124	204

EVOPLUS SMALL - WET ROTOR ELECTRONIC CIRCULATORS

Pumped liquid temperature range: from -10 °C to +110 °C - Maximum operating pressure: 16 bar (1600 kPa)

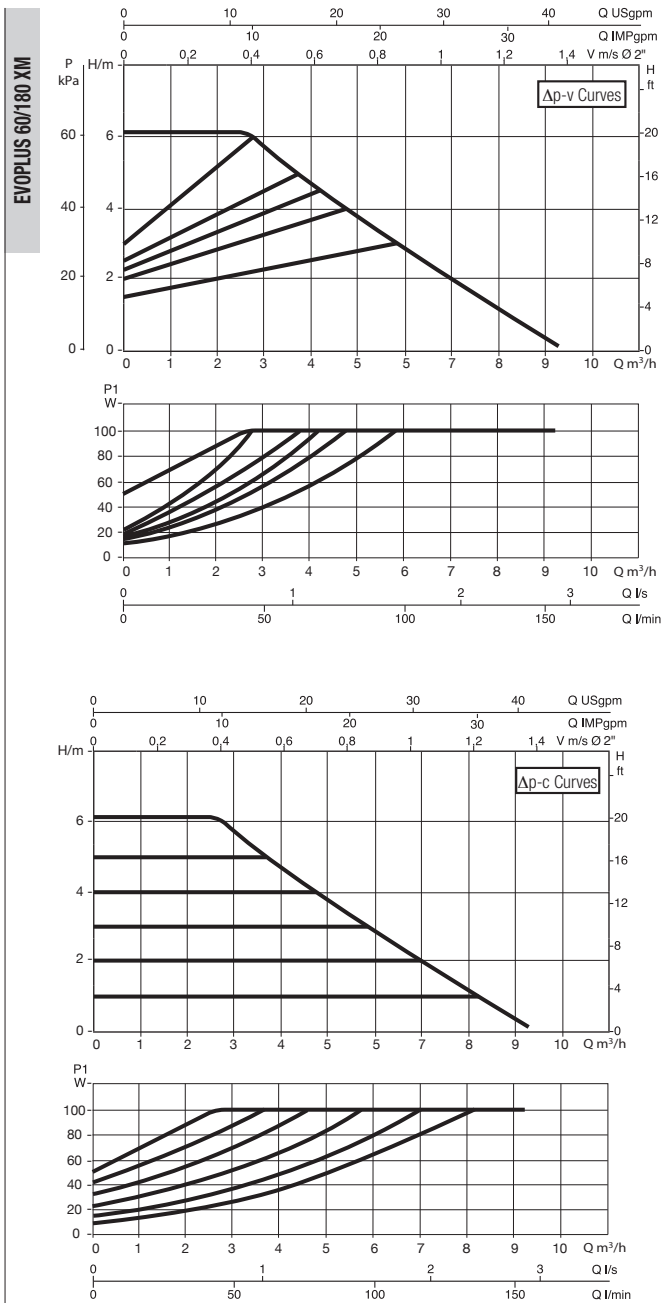
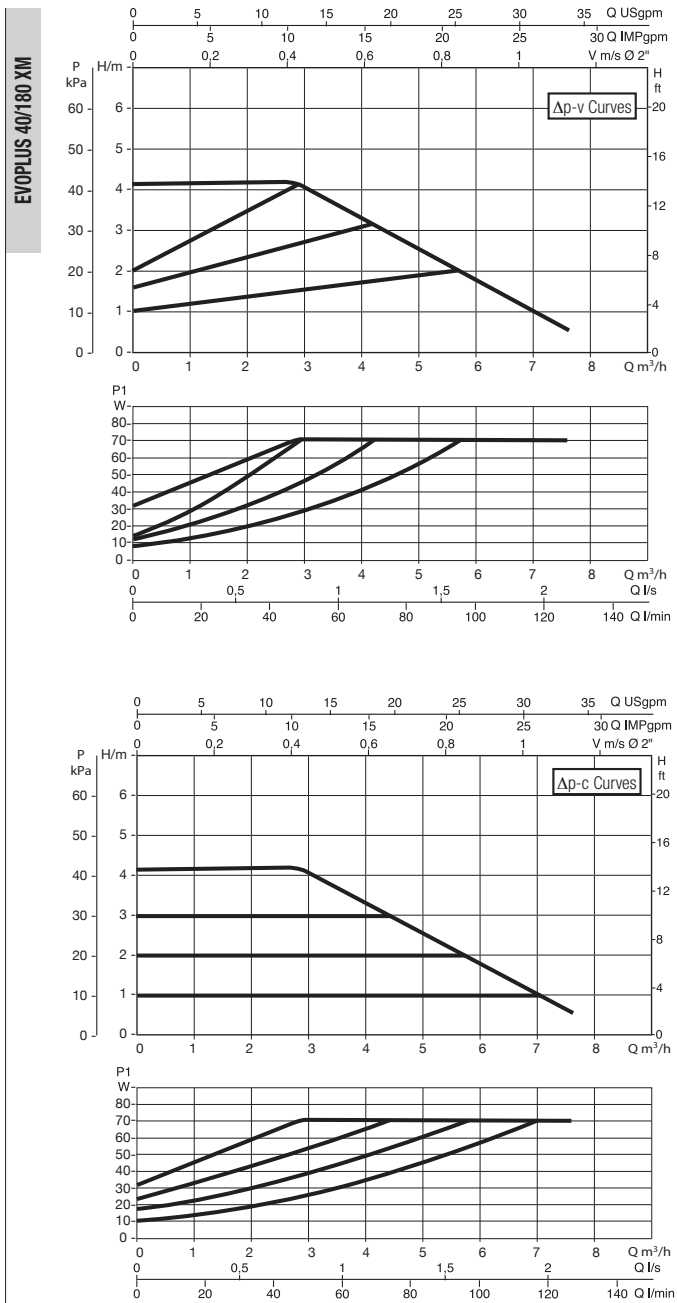

The curves are based on kinematic viscosity values = 1 mm²/s and density equal to 1000 kg/m³. Curve tolerance according to ISO 9906. Fixed speed curves available on the DNA.

MODEL	CENTRE DISTANCE mm	UNIONS ON REQUEST		COUNTERFLANGES ON REQUEST	INPUT POWER 50/60 Hz	P1 MAX W	In A	EEI*	MINIMUM SUCTION PRESSURE			WEIGHT Kg
		STANDARDISED	SPECIAL						t°	90°	100°	
EVOPLUS 40/180 XM	180	1¼" F	-	-	220/240 V	68	0,51	EEI ≤ 0,20	m.c.w.	20	25	4,7
EVOPLUS 60/180 XM	180	1¼" F	-	-	220/240 V	100	0,71	EEI ≤ 0,20	m.c.w.	20	25	4,7

The parameter of reference for the more efficient circulators is EEI ≤ 0,20.

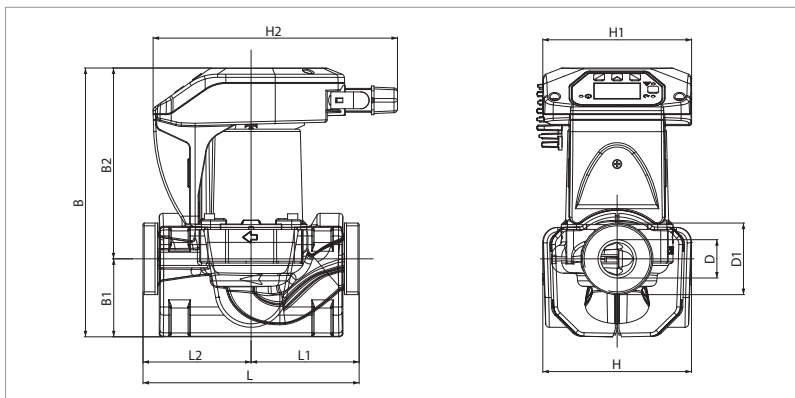

L	L1	L2	B	B1	B2
180	90	90	224	65	159

D	D1	H	H1	H2
32	2"	124	124	204

EVOPLUS SMALL - WET ROTOR ELECTRONIC CIRCULATORS

Pumped liquid temperature range: from -10 °C to +110 °C - Maximum operating pressure: 16 bar (1600 kPa)

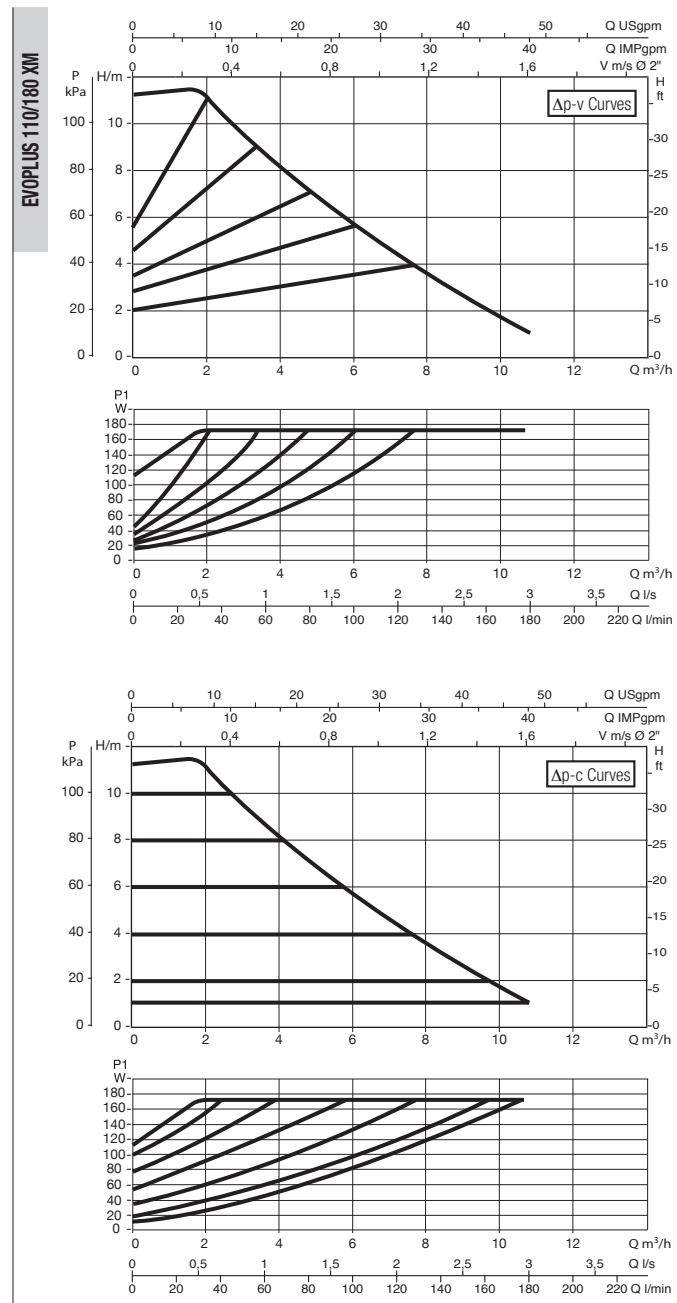
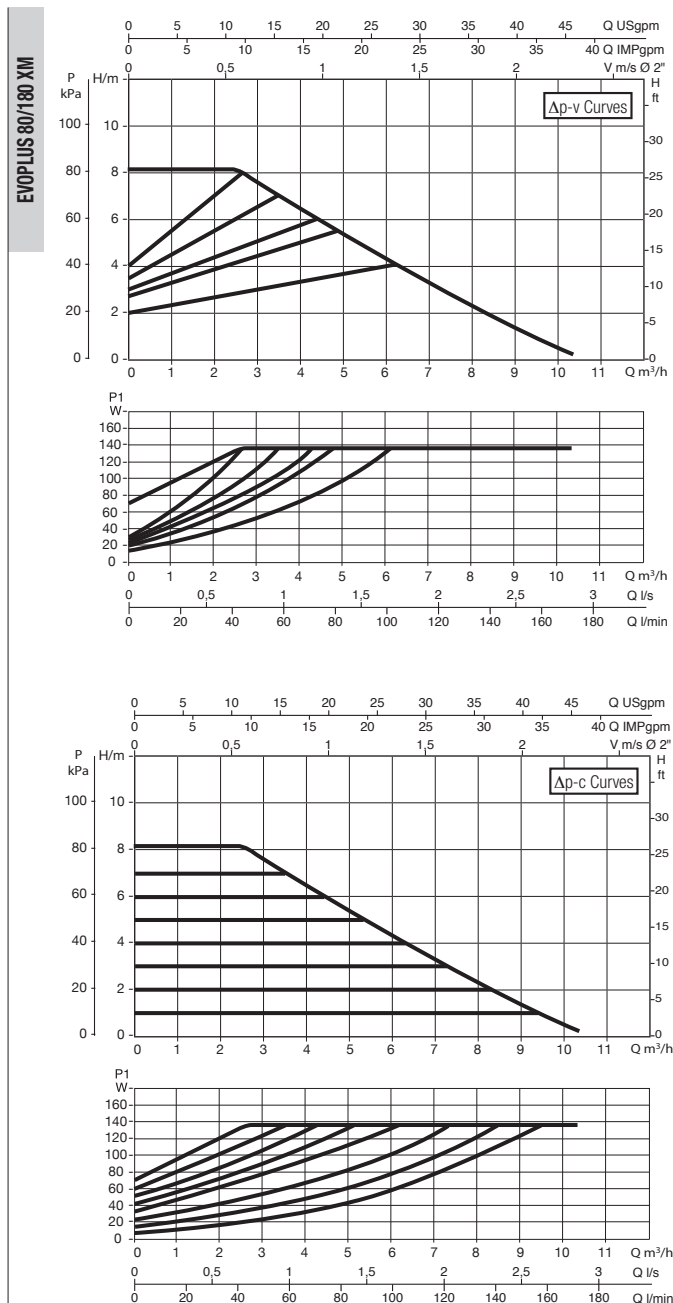

The curves are based on kinematic viscosity values = 1 mm²/s and density equal to 1000 kg/m³. Curve tolerance according to ISO 9906. Fixed speed curves available on the DNA.

MODEL	CENTRE DISTANCE mm	UNIONS ON REQUEST		COUNTERFLANGES ON REQUEST	POWER INPUT 50/60 Hz	P1 MAX W	In A	EEI*	MINIMUM SUCTION PRESSURE			WEIGHT Kg
		STANDARDISED	SPECIAL						t°	90°	100°	
EVOPLUS 80/180 XM	180	1¼" F	-	-	220/240 V	130	0,93	EEI ≤ 0,20	m.c.w.	20	25	4,7
EVOPLUS 110/180 XM	180	1¼" F	-	-	220/240 V	170	1,18	EEI ≤ 0,20	m.c.w.	20	25	4,7

The parameter of reference for the more efficient circulators is EEI ≤ 0,20.

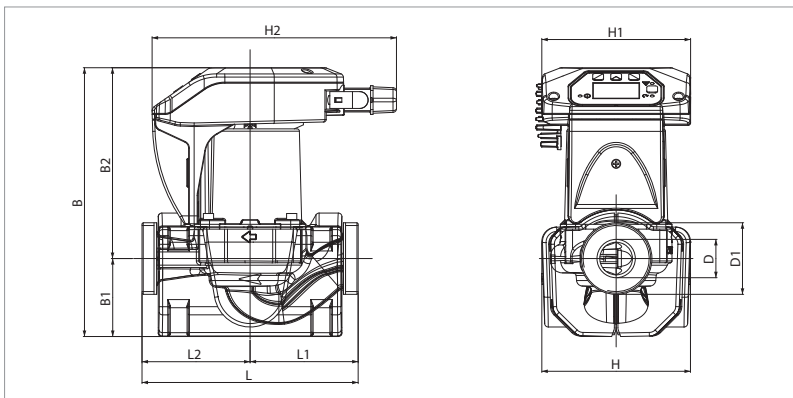

L	L1	L2	B	B1	B2
180	90	90	224	65	159

D	D1	H	H1	H2
32	2"	124	124	204

EVOPLUS SMALL - WET ROTOR ELECTRONIC CIRCULATORS

Pumped liquid temperature range: from -10 °C to +110 °C - Maximum operating pressure: 16 bar (1600 kPa)

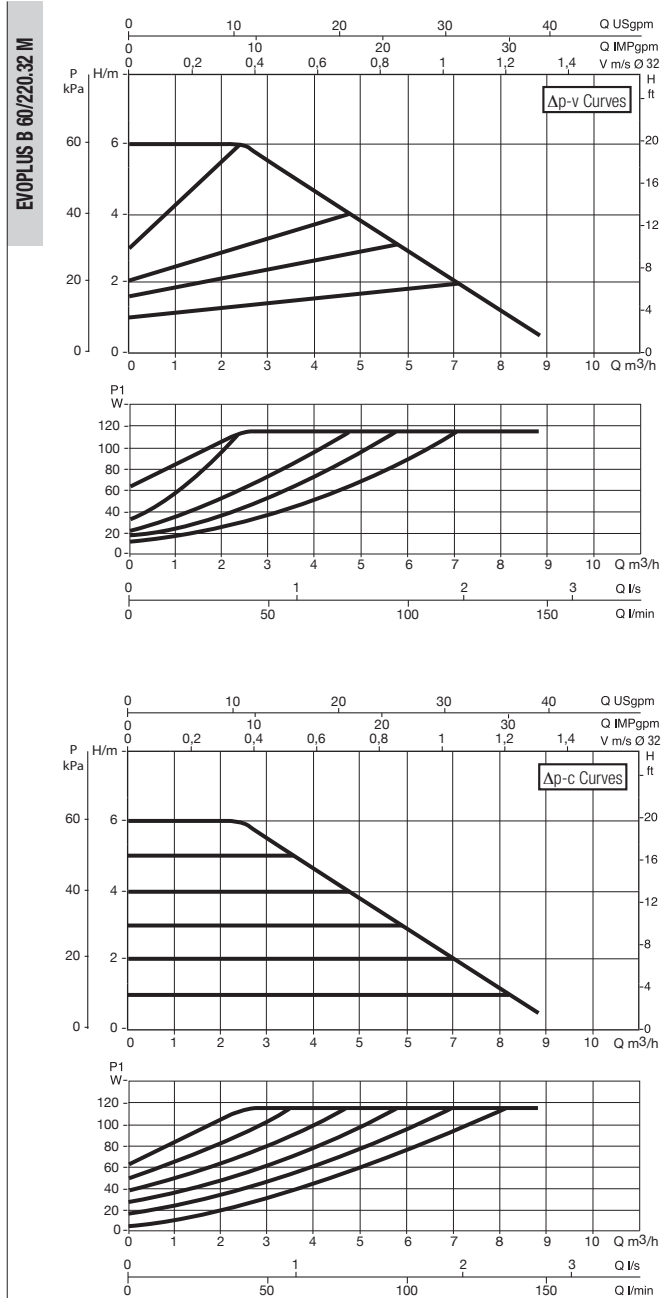
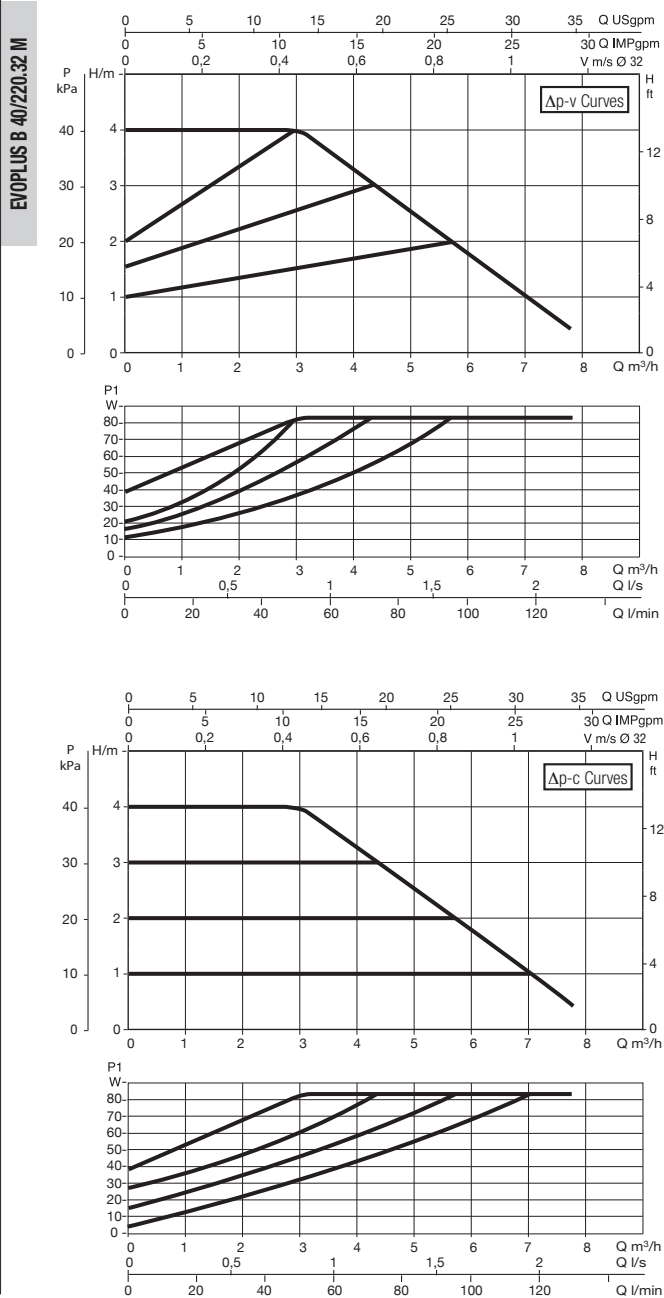

The curves are based on kinematic viscosity values = 1 mm²/s and density equal to 1000 kg/m³. Curve tolerance according to ISO 9906. Fixed speed curves available on the DNA.

MODEL	DISTANCE CENTRE mm	UNIONS ON REQUEST		COUNTERFLANGES ON REQUEST	POWER INPUT 50/60 Hz	P1 MAX W	In A	EEI*	MINIMUM SUCTION PRESSURE			WEIGHT Kg
		STANDARDISED	SPECIAL						t°	90°	100°	
EVOPLUS B 40/220.32 M	220	-	-	DN32 PN 6	220/240 V	68	0,55	EEI ≤ 0,20	m.c.w.	20	25	7,5
EVOPLUS B 60/220.32 M	220	-	-	DN32 PN 6	220/240 V	100	0,75	EEI ≤ 0,20	m.c.w.	20	25	7,5

The parameter of reference for the more efficient circulators is EEI ≤ 0,20.

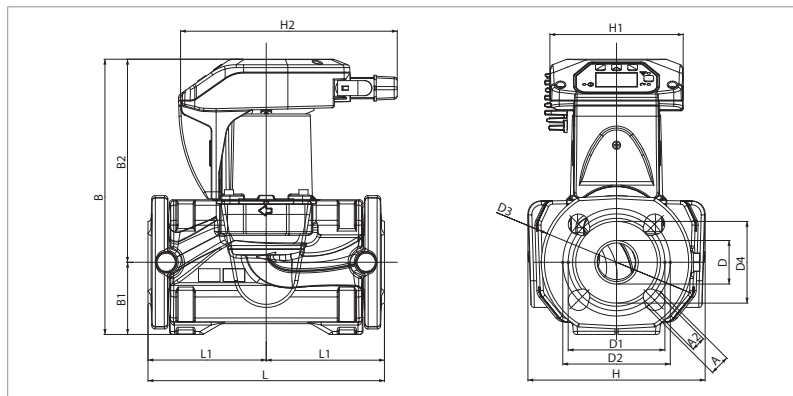

L	L1	L2	A	A2	B	B1	B2
220	110	110	19	14	256	67	189

D	D1	D2	D3	D4	H	H1	H2
40	90	100	140	76	165	124	204

EVOPLUS SMALL - WET ROTOR ELECTRONIC CIRCULATORS

Pumped liquid temperature range: from -10 °C to +110 °C - Maximum operating pressure: 16 bar (1600 kPa)

EVOPLUS B 80/220.32 M

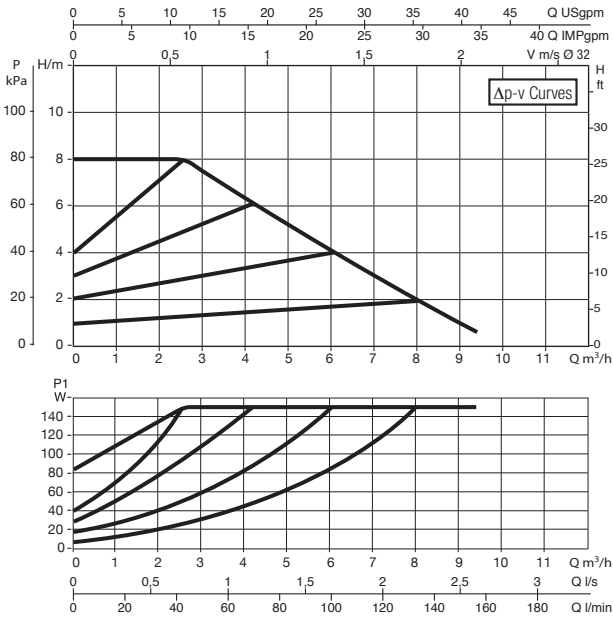

EVOPLUS B 110/220.32 M

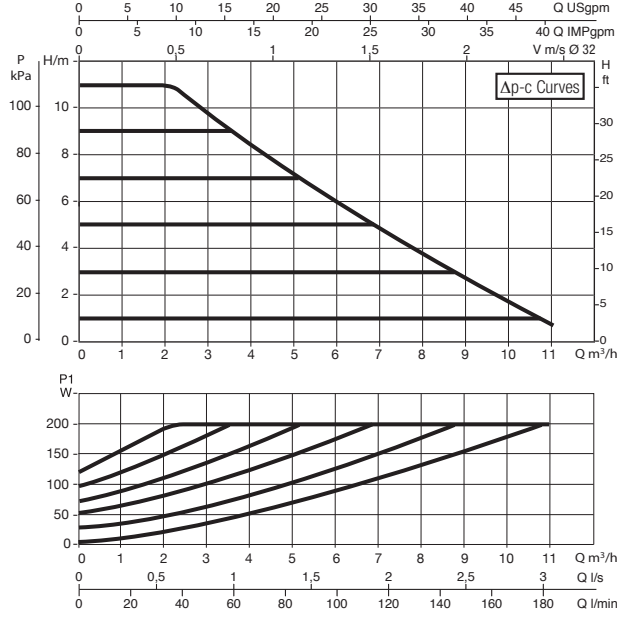
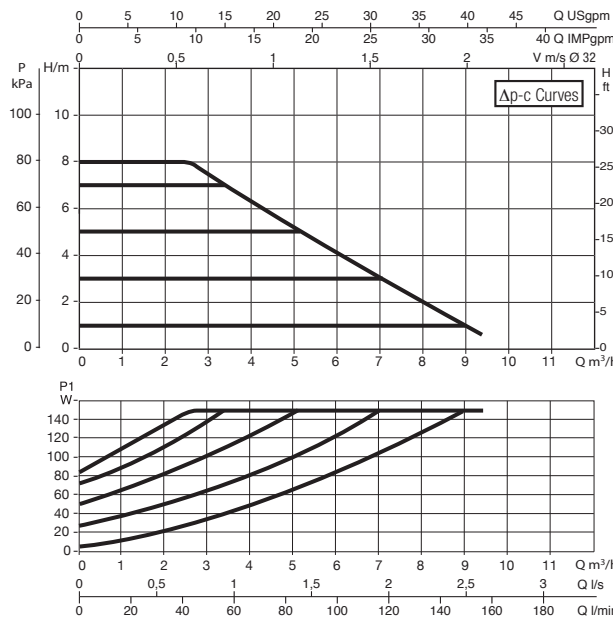
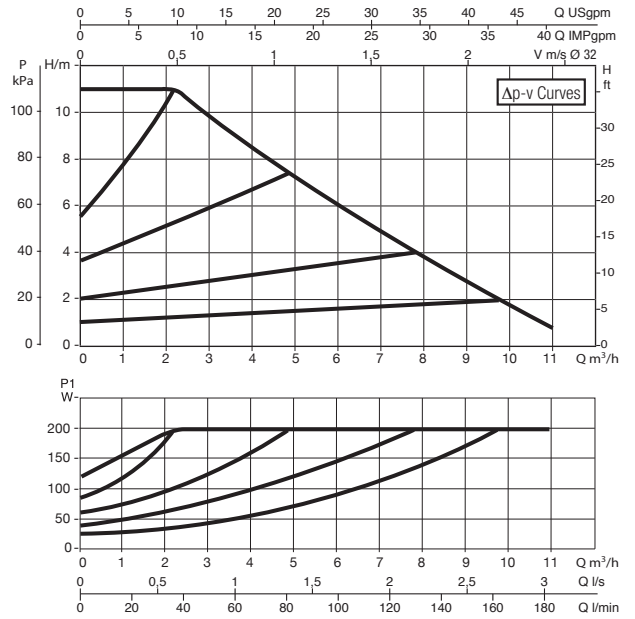

The curves are based on kinematic viscosity values = 1 mm²/s and density equal to 1000 kg/m³. Curve tolerance according to ISO 9906. Fixed speed curves available on the DNA.

MODEL	CENTRE DISTANCE mm	UNIONS ON REQUEST		COUNTERFLANGES ON REQUEST	POWER INPUT 50/60 Hz	P1 MAX W	In A	EEI *	MINIMUM SUCTION PRESSURE			WEIGHT Kg
		STANDARDISED	SPECIAL						t°	90°	100°	
EVOPLUS B 80/220.32 M	220	-	-	DN32 PN 6	220/240 V	132	0,97	EEI ≤ 0,20	m.c.w.	20	25	7,5
EVOPLUS B 110/220.32 M	220	-	-	DN32 PN 6	220/240 V	180	1,3	EEI ≤ 0,20	m.c.w.	20	25	7,5

The parameter of reference for the more efficient circulators is EEI ≤ 0,20.

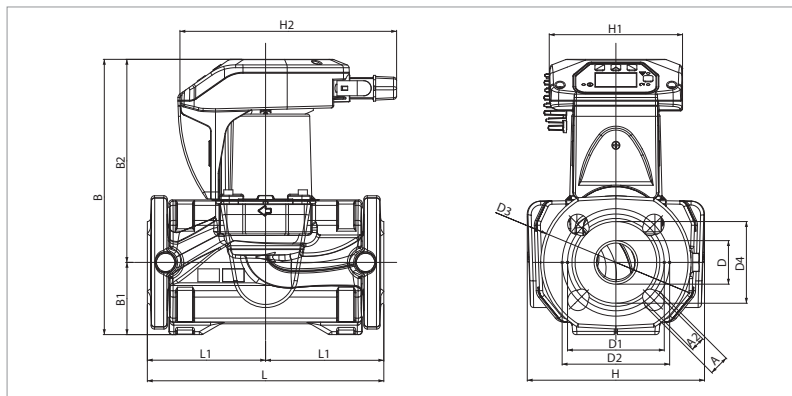

L	L1	L2	A	A2	B	B1	B2
220	110	110	19	14	256	67	189

D	D1	D2	D3	D4	H	H1	H2
40	90	100	140	76	165	124	204

EVOPLUS SMALL - WET ROTOR ELECTRONIC CIRCULATORS

Pumped liquid temperature range: from -10 °C to +110 °C - Maximum operating pressure: 16 bar (1600 kPa)

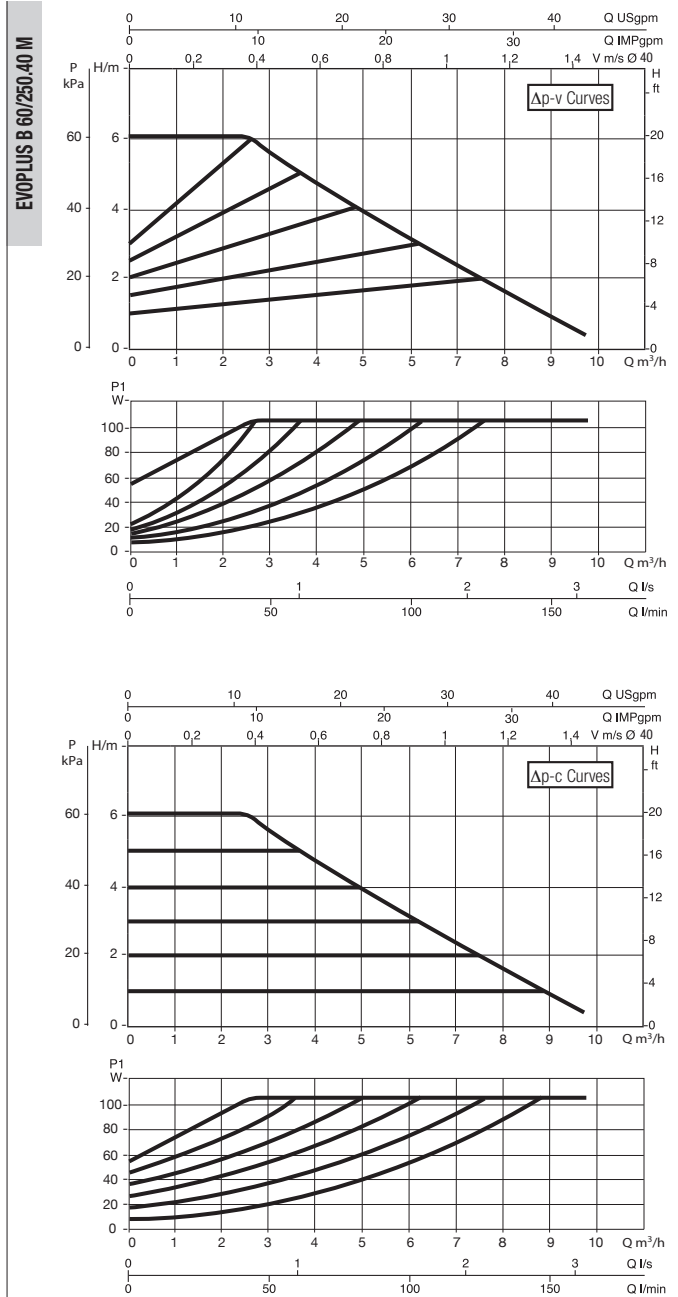
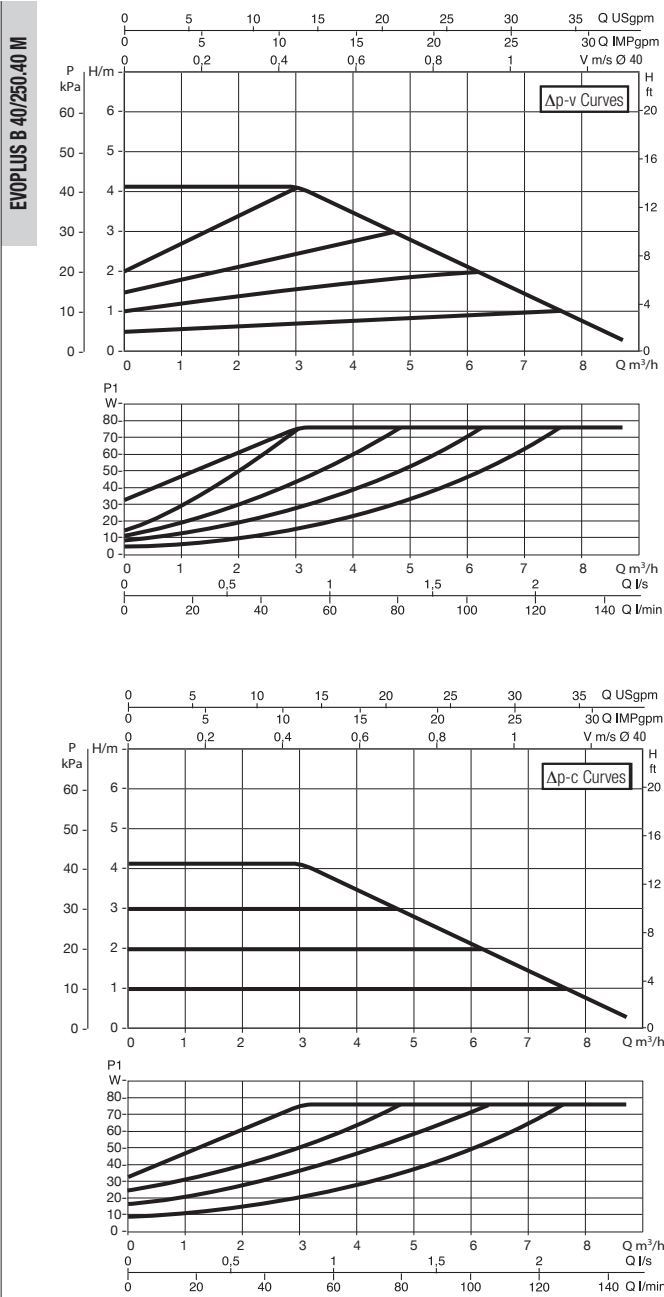

The curves are based on kinematic viscosity values = 1 mm²/s and density equal to 1000 kg/m³. Curve tolerance according to ISO 9906. Fixed speed curves available on the DNA.

MODEL	CENTRE DISTANCE mm	UNIONS ON REQUEST		COUNTERFLANGES ON REQUEST	POWER INPUT 50/60 Hz	P1 MAX W	I _n A	EEI*	MINIMUM SUCTION PRESSURE			WEIGHT Kg
		STANDARDISED	SPECIAL						t°	90°	100°	
EVOPLUS B 40/250.40 M	250	-	-	DN40 PN 10	220/240 V	70	0,55	EEI ≤ 0,20	m.c.w.	20	25	7,5
EVOPLUS B 60/250.40 M	250	-	-	DN40 PN 10	220/240 V	100	0,75	EEI ≤ 0,20	m.c.w.	20	25	7,5

The parameter of reference for the more efficient circulators is EEI ≤ 0,20.

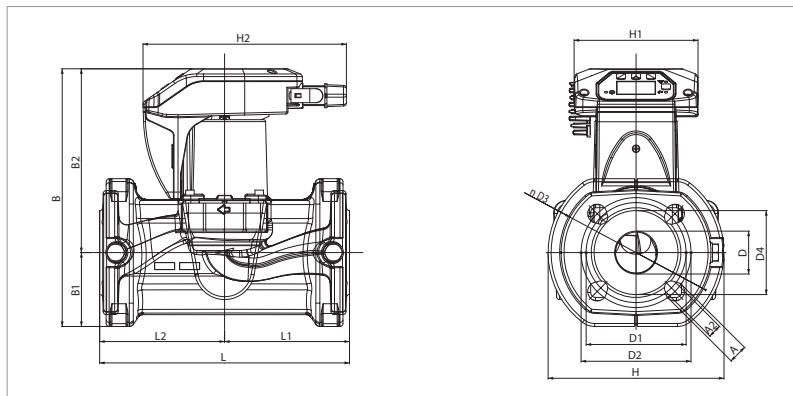

L	L1	L2	A	A2	B	B1	B2
250	125	125	19	14	258	74	184

D	D1	D2	D3	D4	H	H1	H2
43	100	110	150	84	176	124	204

EVOPLUS SMALL - WET ROTOR ELECTRONIC CIRCULATORS

Pumped liquid temperature range: from -10 °C to +110 °C - Maximum operating pressure: 16 bar (1600 kPa)

EVOPLUS B 80/250.40 M

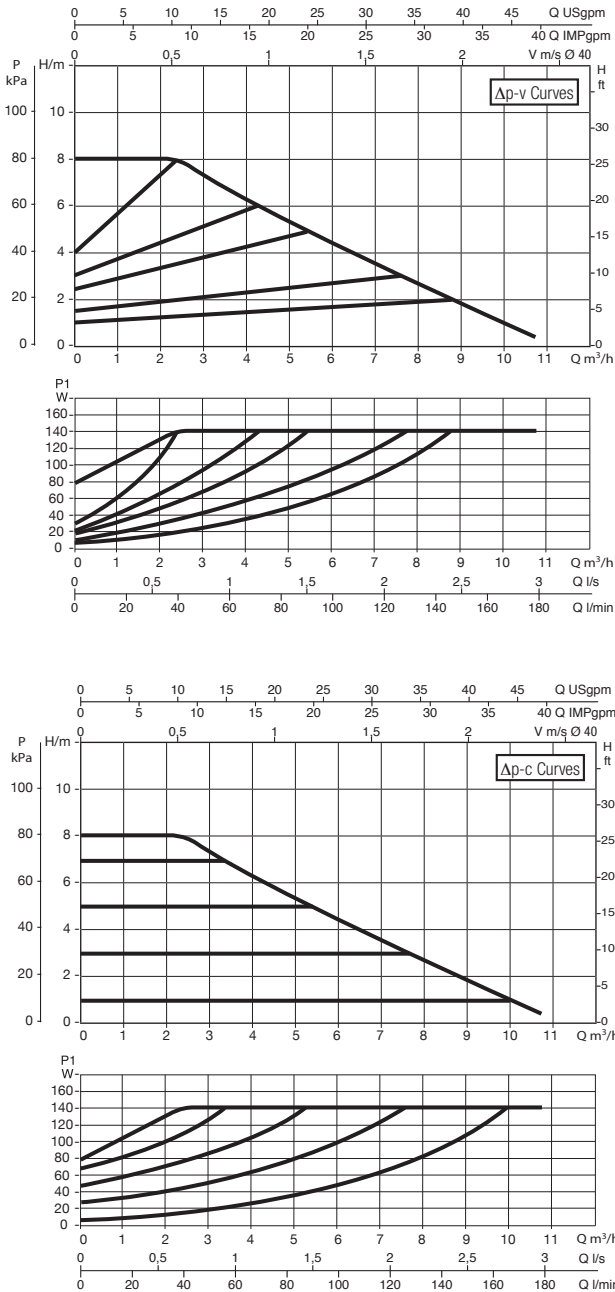

EVOPLUS B 110/250.40 M

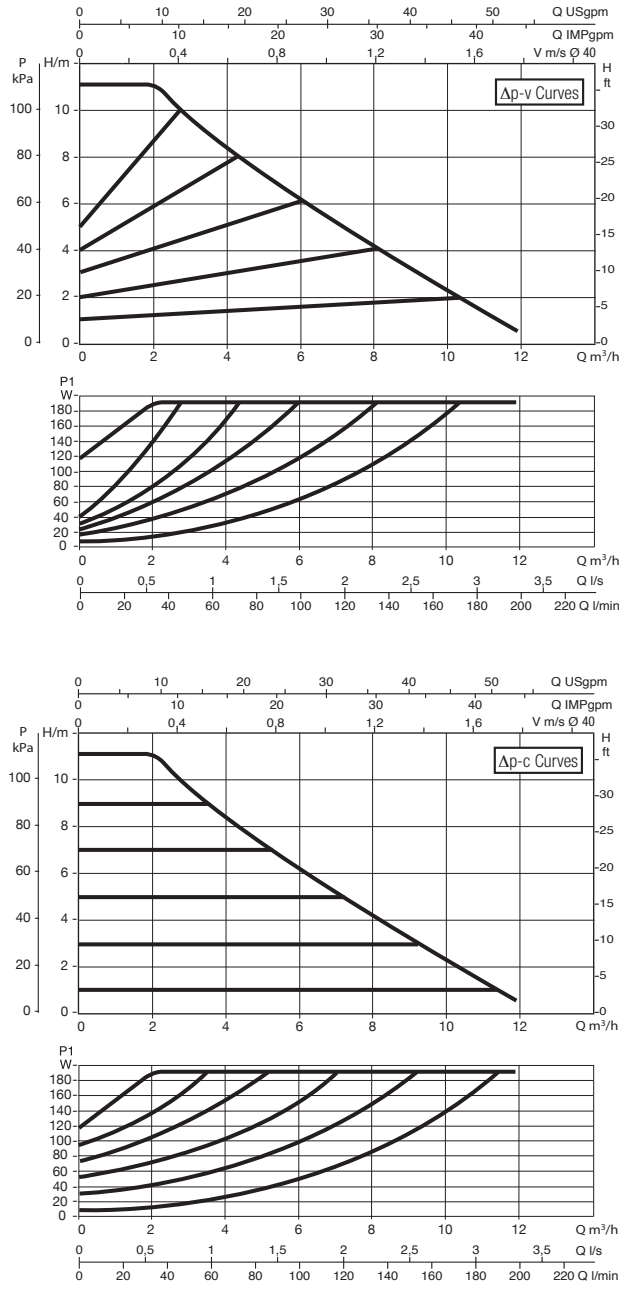

The curves are based on kinematic viscosity values = 1 mm²/s and density equal to 1000 kg/m³. Curve tolerance according to ISO 9906. Fixed speed curves available on the DNA.

MODEL	CENTRE DISTANCE mm	UNIONS ON REQUEST		COUNTERFLANGES ON REQUEST	POWER INPUT 50/60 Hz	P1 MAX W	In A	EEI*	MINIMUM SUCTION PRESSURE			WEIGHT Kg
		STANDARDISED	SPECIAL						t°	90°	100°	
EVOPLUS B 80/250.40 M	250	-	-	DN40 PN 10	220/240 V	132	0,97	EEI ≤ 0,20	m.c.w.	20	25	7,5
EVOPLUS B 110/250.40 M	250	-	-	DN40 PN 10	220/240 V	180	1,3	EEI ≤ 0,20	m.c.w.	20	25	7,5

The parameter of reference for the more efficient circulators is EEI ≤ 0,20.

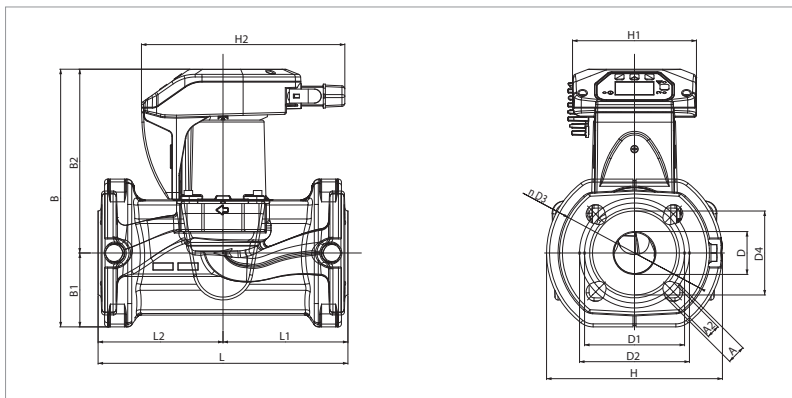

L	L1	L2	A	A2	B	B1	B2
250	125	125	19	14	258	74	184

D	D1	D2	D3	D4	H	H1	H2
43	100	110	150	84	176	124	204

EVOPLUS SMALL - WET ROTOR ELECTRONIC CIRCULATORS

Pumped liquid temperature range: from -10 °C to +110 °C - Maximum operating pressure: 16 bar (1600 kPa)

EVOPLUS D 40/220.32 M

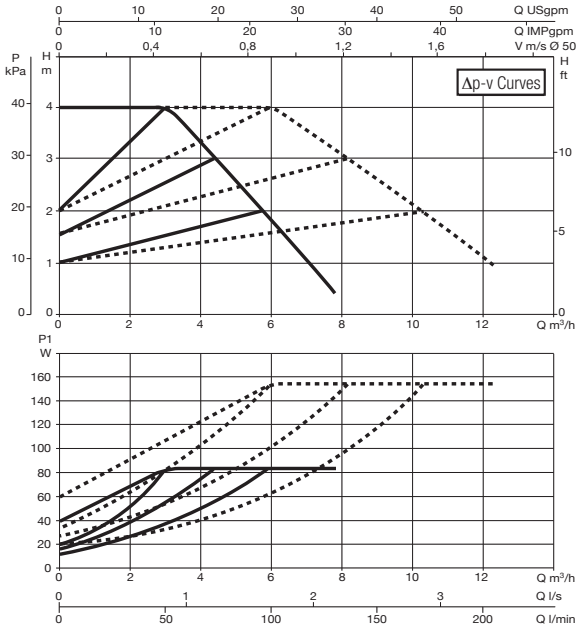

EVOPLUS D 60/220.32 M

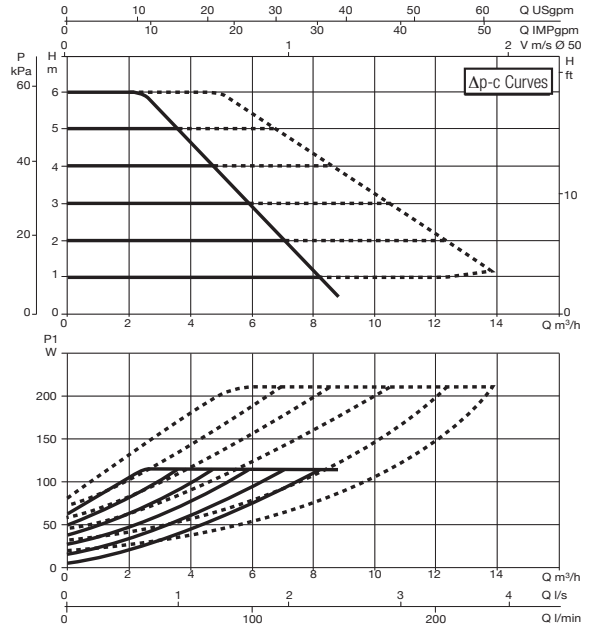
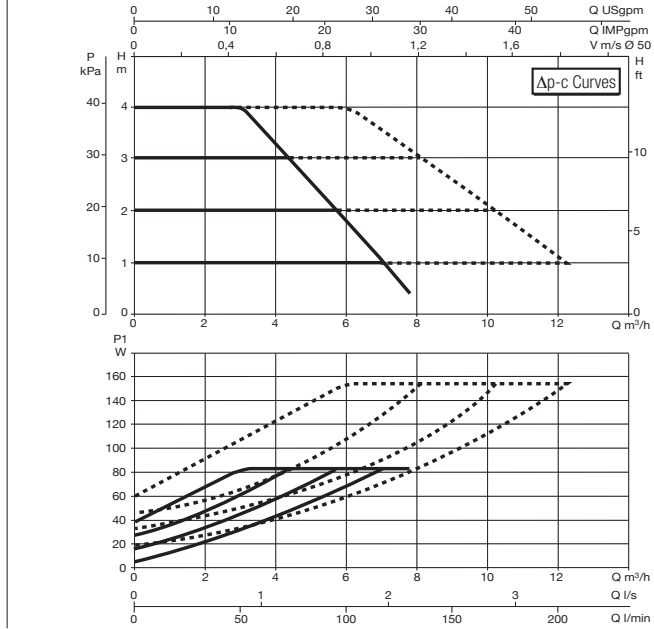
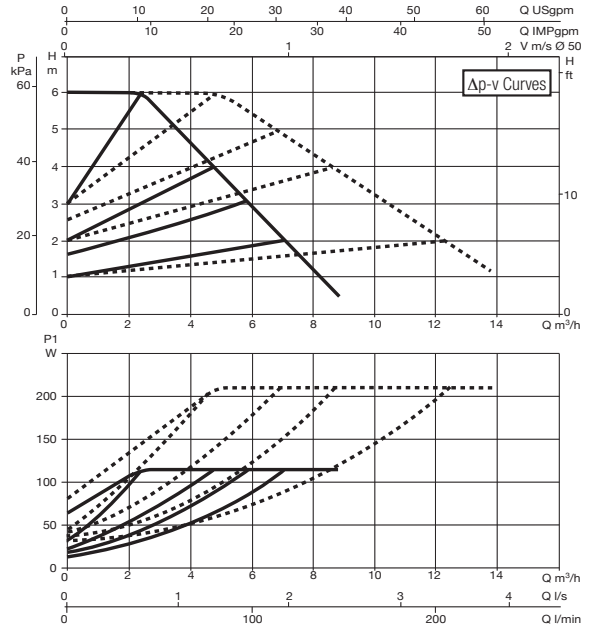

The curves are based on kinematic viscosity values = 1 mm²/s and density equal to 1000 kg/m³. Curve tolerance according to ISO 9906. Fixed speed curves available on the DNA.

MODEL	CENTRE DISTANCE mm	UNIONS ON REQUEST		COUNTERFLANGES ON REQUEST	POWER INPUT 50/60 Hz	P1 MAX W	In A	EEI*	MINIMUM SUCTION PRESSURE			WEIGHT Kg
		STANDARDISED	SPECIAL						t°	90°	100°	
EVOPLUS D 40/220.32 M	220	-	-	DN32 PN 6	220/240 V	70	0,55	EEI ≤ 0,20	m.c.w.	20	25	13,5
EVOPLUS D 60/220.32 M	220	-	-	DN32 PN 6	220/240 V	95	0,75	EEI ≤ 0,20	m.c.w.	20	25	13,5

The parameter of reference for the more efficient circulators is EEI ≤ 0,20.

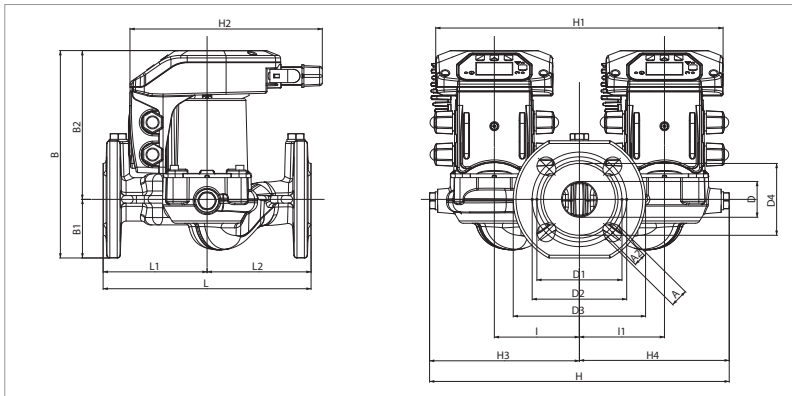

L	L1	L2	A	A2	B	B1	B2	D	D1
220	110	110	19	14	220	62	158	40	90

D2	D3	D4	I	I1	H	H1	H2	H3	H4
100	140	76	90	90	300	304	204	150	150

EVOPLUS SMALL - WET ROTOR ELECTRONIC CIRCULATORS

Pumped liquid temperature range: from -10 °C to +110 °C - Maximum operating pressure: 16 bar (1600 kPa)

EVOPLUS D 80/220.32 M

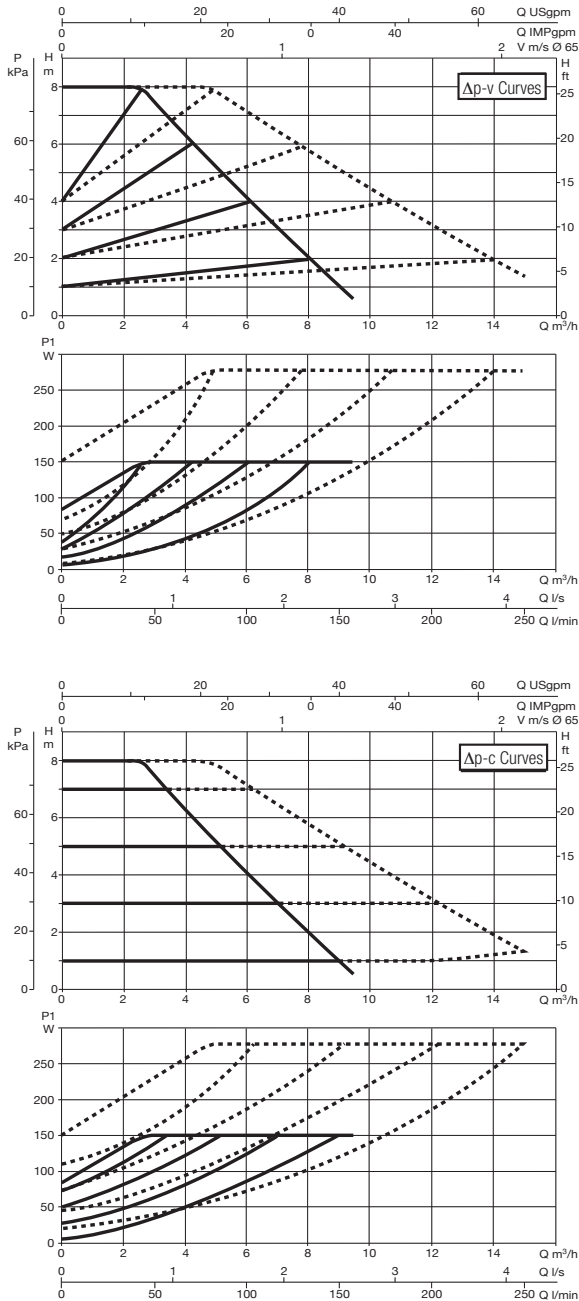

EVOPLUS D 110/220.32 M

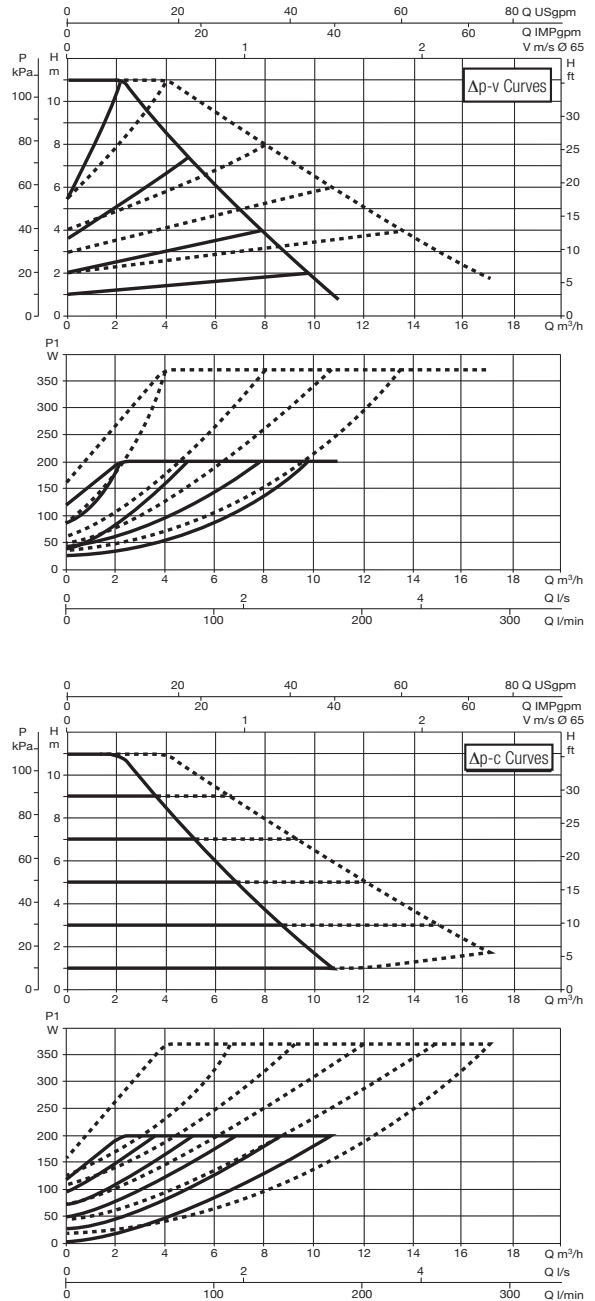

The curves are based on kinematic viscosity values = 1 mm²/s and density equal to 1000 kg/m³. Curve tolerance according to ISO 9906. Fixed speed curves available on the DNA.

MODEL	CENTRE DISTANCE mm	UNIONS ON REQUEST		COUNTERFLANGES ON REQUEST	POWER INPUT 50/60 Hz	P1 MAX W	In A	EEI *	MINIMUM SUCTION PRESSURE			WEIGHT Kg
		STANDARDISED	SPECIAL						t°	90°	100°	
EVOPLUS D 80/220.32 M	220	-	-	DN32 PN 6	220/240 V	130	0,95	EEI ≤ 0,20	m.c.w.	20	25	13,5
EVOPLUS D 110/220.32 M	220	-	-	DN32 PN 6	220/240 V	190	1,3	EEI ≤ 0,20	m.c.w.	20	25	13,5

The parameter of reference for the more efficient circulators is EEI ≤ 0,20.

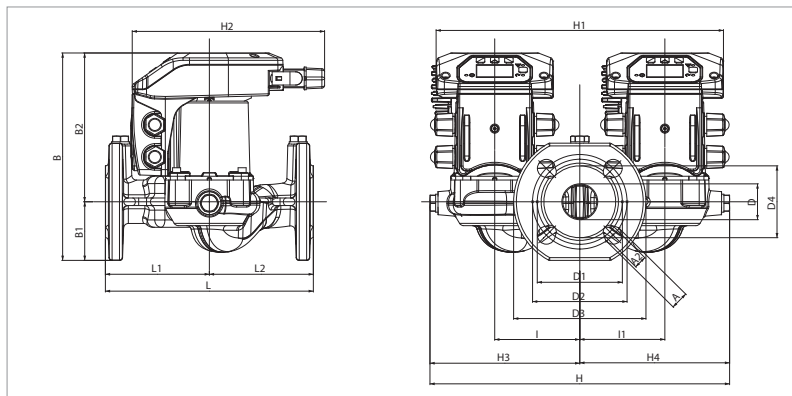

L	L1	L2	A	A2	B	B1	B2	D	D1
220	110	110	19	14	220	62	158	40	90

D2	D3	D4	I	I1	H	H1	H2	H3	H4
100	140	76	90	90	300	304	204	150	150

EVOPLUS SMALL - WET ROTOR ELECTRONIC CIRCULATORS

Pumped liquid temperature range: from -10 °C to +110 °C - Maximum operating pressure: 16 bar (1600 kPa)

EVOPLUS D 40/250.40 M

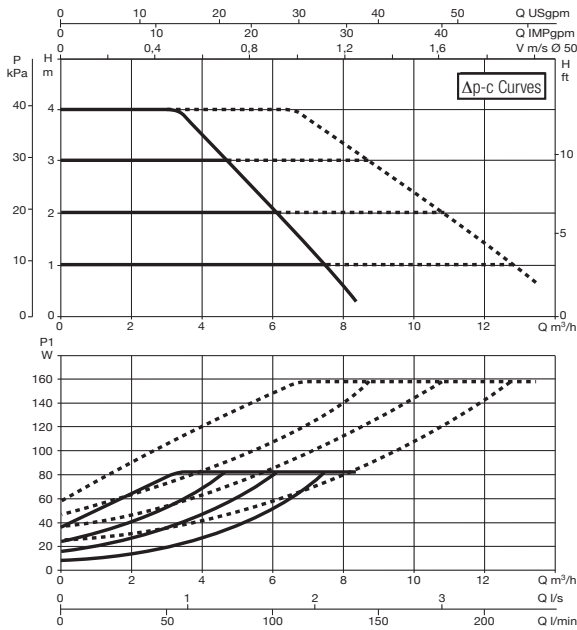
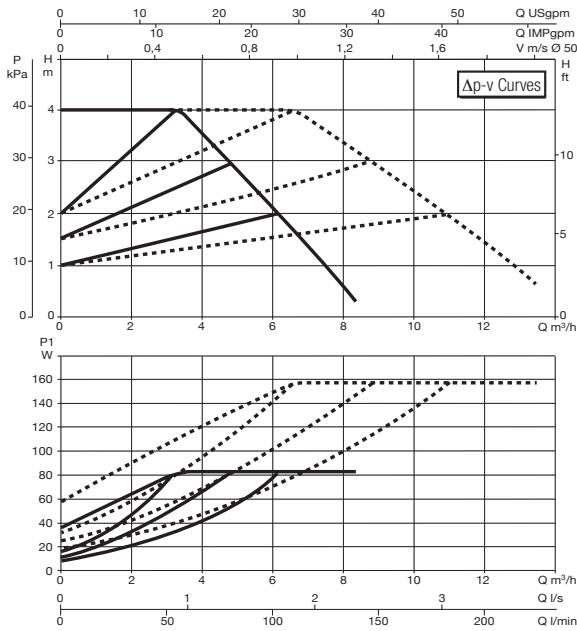

EVOPLUS D 60/250.40 M

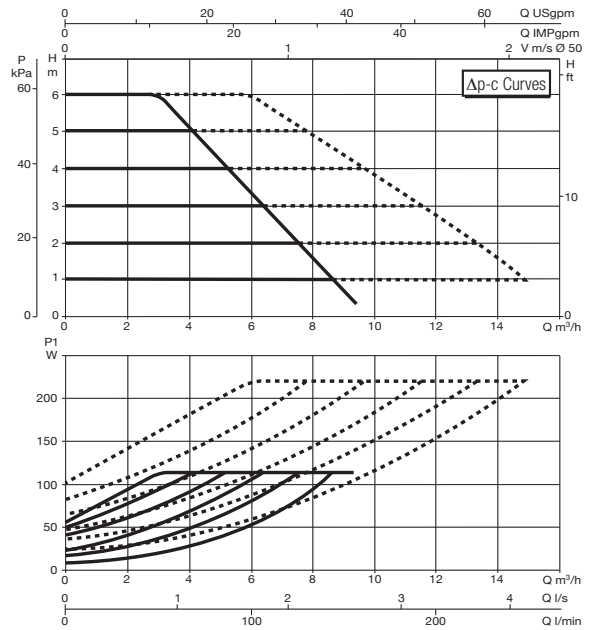
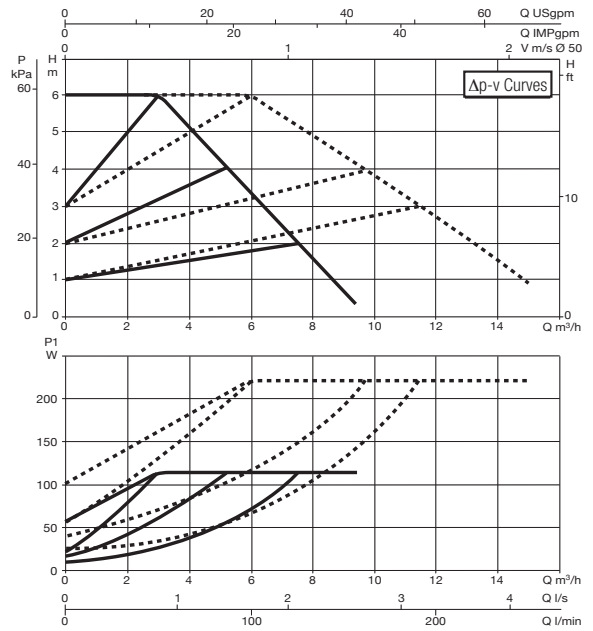

The curves are based on kinematic viscosity values = 1 mm²/s and density equal to 1000 kg/m³. Curve tolerance according to ISO 9906. Fixed speed curves available on the DNA.

MODEL	CENTRE DISTANCE mm	UNIONS ON REQUEST		COUNTERFLANGES ON REQUEST	POWER INPUT 50/60 Hz	P1 MAX W	I _n A	EEI*	MINIMUM SUCTION PRESSURE			WEIGHT Kg
		STANDARDISED	SPECIAL						t°	90°	100°	
EVOPLUS D 40/250.40 M	250	-	-	DN40 PN 10	220/240 V	75	0,55	EEI ≤ 0,20	m.c.w.	20	25	14,2
EVOPLUS D 60/250.40 M	250	-	-	DN40 PN 10	220/240 V	100	0,75	EEI ≤ 0,20	m.c.w.	20	25	14,2

The parameter of reference for the more efficient circulators is EEI ≤ 0,20.

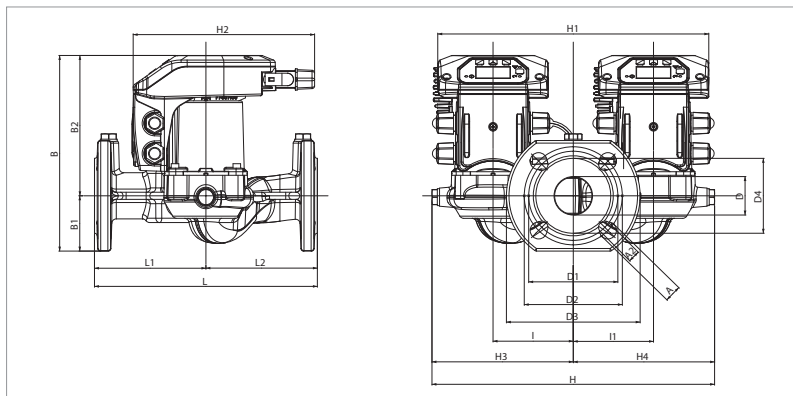

L	L1	L2	A	A2	B	B1	B2	D	D1
250	125	125	19	14	220	62	158	43	100

D2	D3	D4	I	I1	H	H1	H2	H3	H4
110	150	84	90	90	300	304	204	150	150

EVOPLUS SMALL - WET ROTOR ELECTRONIC CIRCULATORS

Pumped liquid temperature range: from -10 °C to +110 °C - Maximum operating pressure: 16 bar (1600 kPa)

EVOPLUS D 80/250.40 M

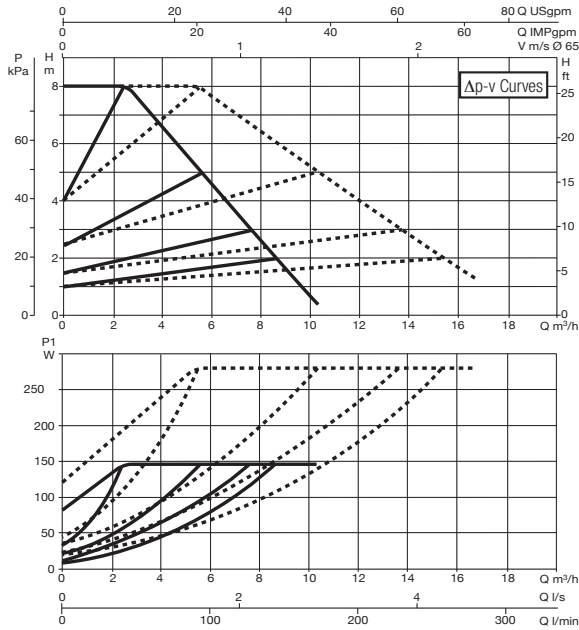

EVOPLUS D 110/250.40 M

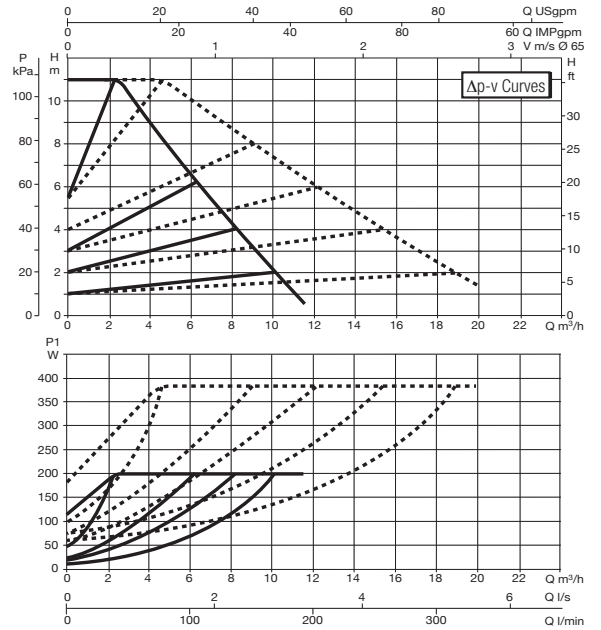

EVOPLUS D 80/250.40 M

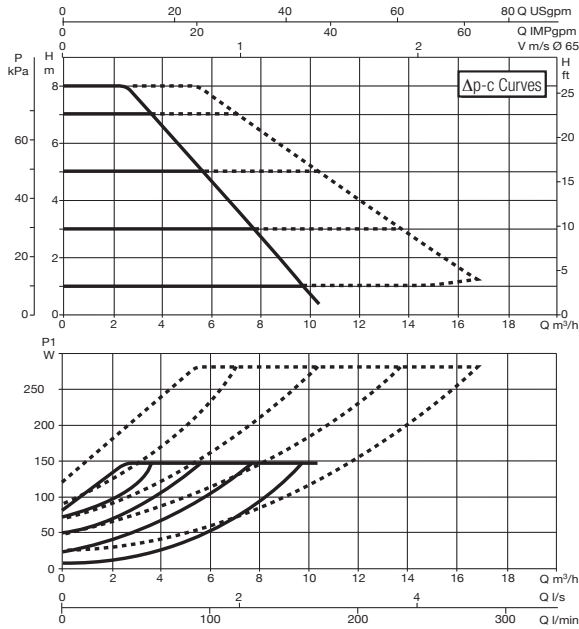

EVOPLUS D 110/250.40 M

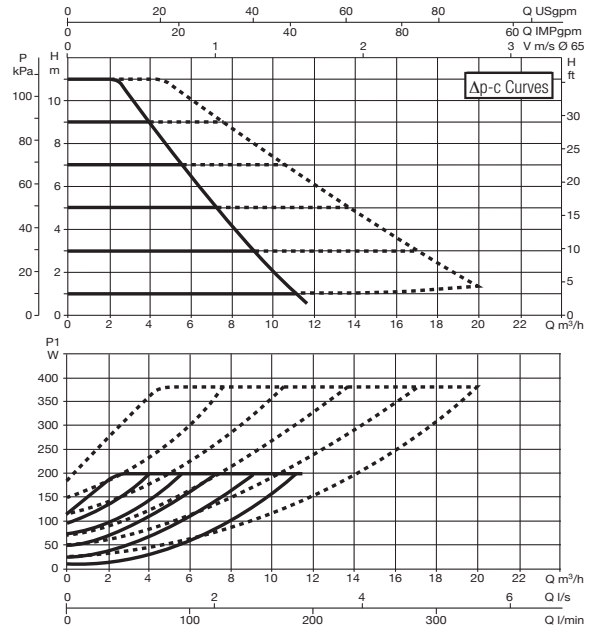

The curves are based on kinematic viscosity values = 1 mm²/s and density equal to 1000 kg/m³. Curve tolerance according to ISO 9906. Fixed speed curves available on the DNA.

MODEL	CENTRE DISTANCE mm	UNIONS ON REQUEST		COUNTERFLANGES ON REQUEST	POWER INPUT 50/60 Hz	P1 MAX W	In A	EEI*	MINIMUM SUCTION PRESSURE			WEIGHT Kg
		STANDARDISED	SPECIAL						t°	90°	100°	
EVOPLUS D 80/250.40 M	250	-	-	DN40 PN 10	220/240 V	135	0,95	EEI ≤ 0,20	m.c.w.	20	25	14,2
EVOPLUS D 110/250.40 M	250	-	-	DN40 PN 10	220/240 V	190	1,3	EEI ≤ 0,20	m.c.w.	20	25	14,2

The parameter of reference for the more efficient circulators is EEI ≤ 0,20.

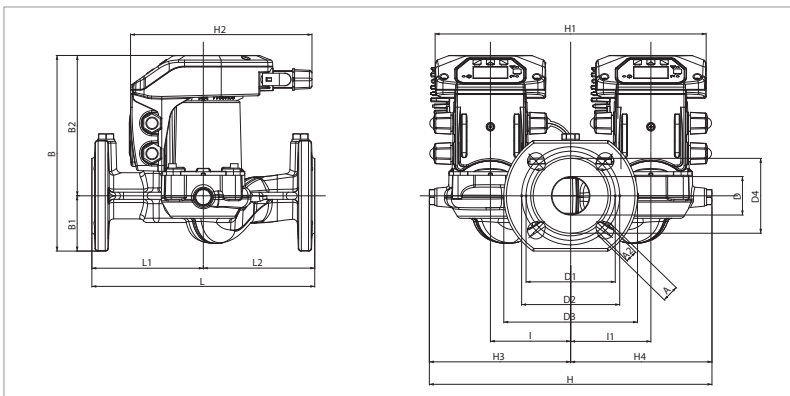

L	L1	L2	A	A2	B	B1	B2	D	D1
250	125	125	19	14	220	62	158	43	100

D2	D3	D4	I	I1	H	H1	H2	H3	H4
110	150	84	90	90	300	304	204	150	150

EVOPLUS SMALL SAN - WET ROTOR ELECTRONIC CIRCULATORS

Pumped liquid temperature range: from -10 °C to +110 °C - Maximum operating pressure: 16 bar (1600 kPa)

EVOPLUS 40/180 SAN M

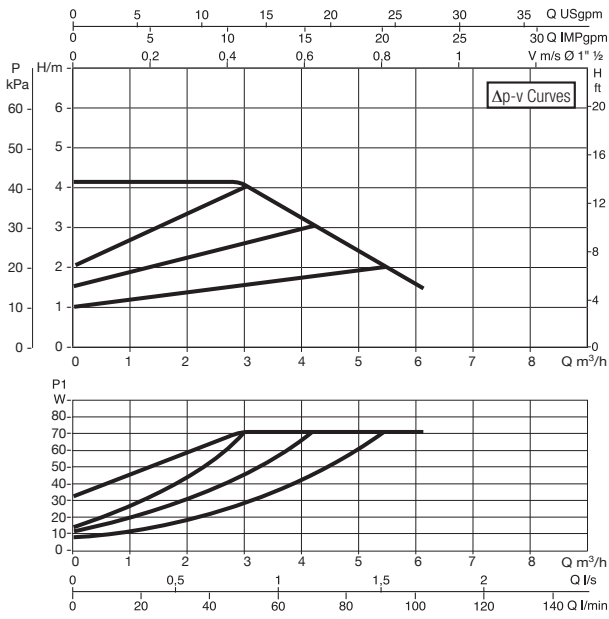

EVOPLUS 60/180 SAN M

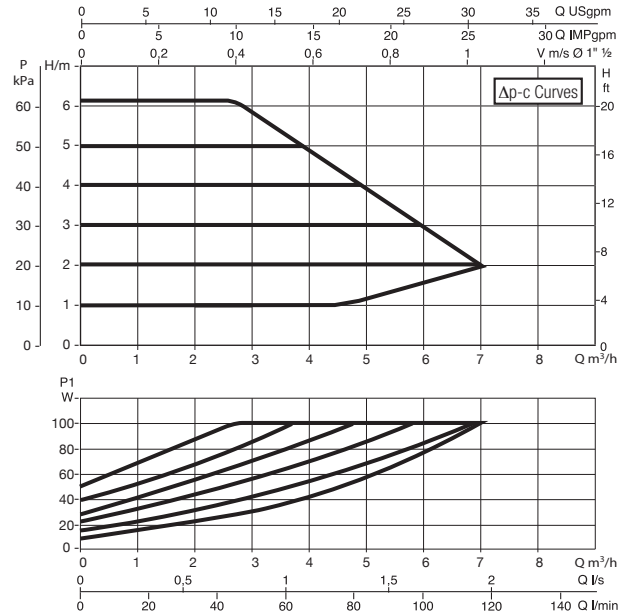
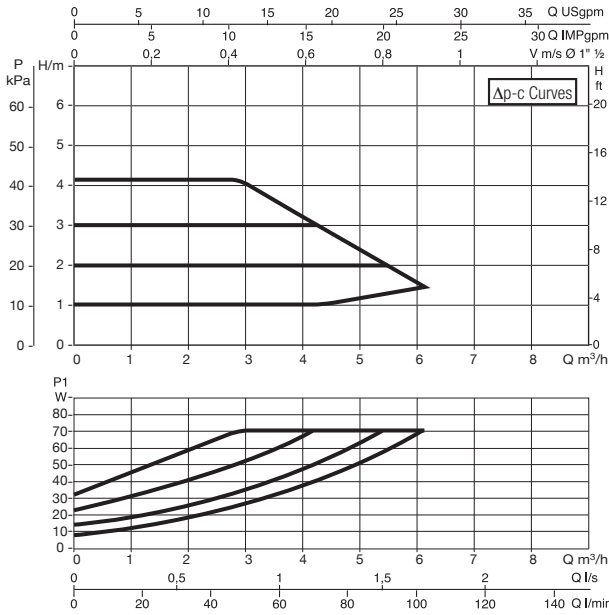
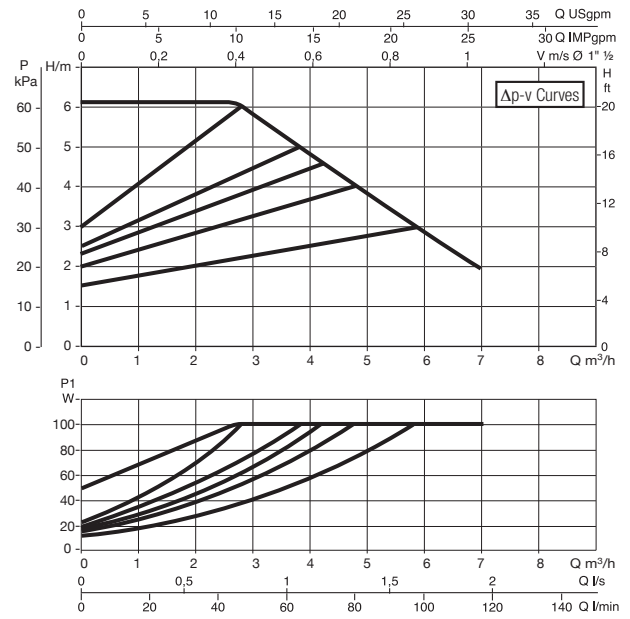

The curves are based on kinematic viscosity values = 1 mm²/s and density equal to 1000 kg/m³. Curve tolerance according to ISO 9906. Fixed speed curves available on the DNA.

MODEL	CENTRE DISTANCE mm	UNIONS ON REQUEST		COUNTERFLANGES ON REQUEST	POWER INPUT 50/60 Hz	P1 MAX W	In A	MINIMUM SUCTION PRESSURE			WEIGHT Kg
		STANDARDISED	SPECIAL					t°	90°	100°	
EVOPLUS 40/180 SAN M	180	1" F	1/2" F - 3/4" F	-	220/240 V	70	0,52	m.c.w.	20	25	4,5
EVOPLUS 60/180 SAN M	180	1" F	1/2" F - 3/4" F	-	220/240 V	100	0,72	m.c.w.	20	25	4,5

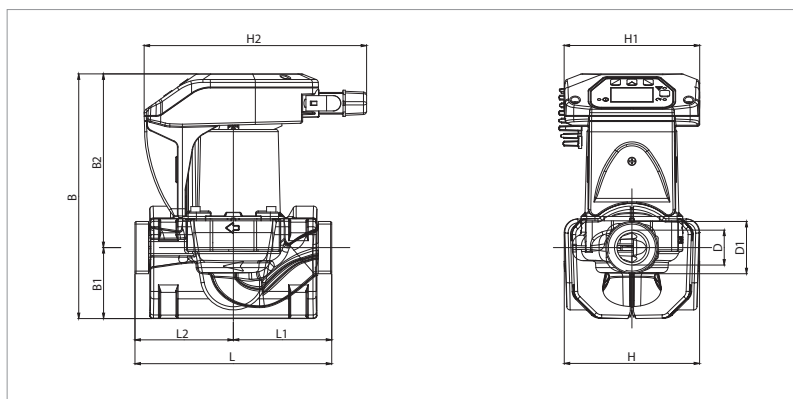

L	L1	L2	B	B1	B2	D	D1	H	H1	H2
180	90	90	224	65	159	32	1 1/2"	124	124	204

EVOPLUS SMALL SAN - WET ROTOR ELECTRONIC CIRCULATORS

Pumped liquid temperature range: from -10 °C to +110 °C - Maximum operating pressure: 16 bar (1600 kPa)

EVOPLUS 80/180 SAN M

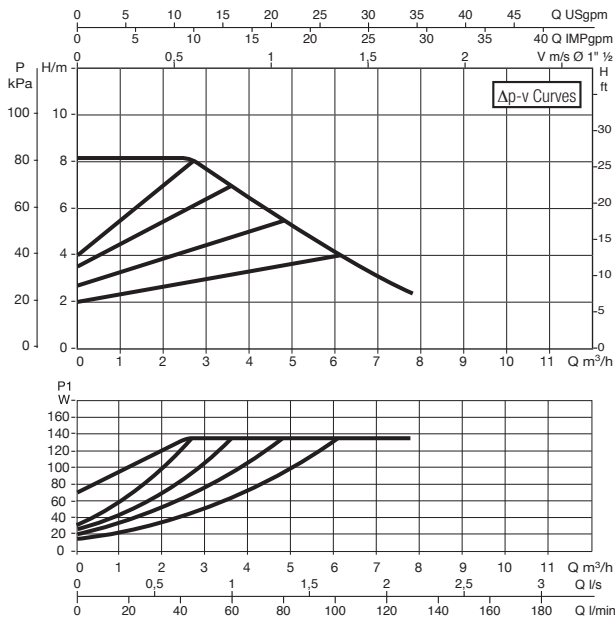

EVOPLUS 110/180 SAN M

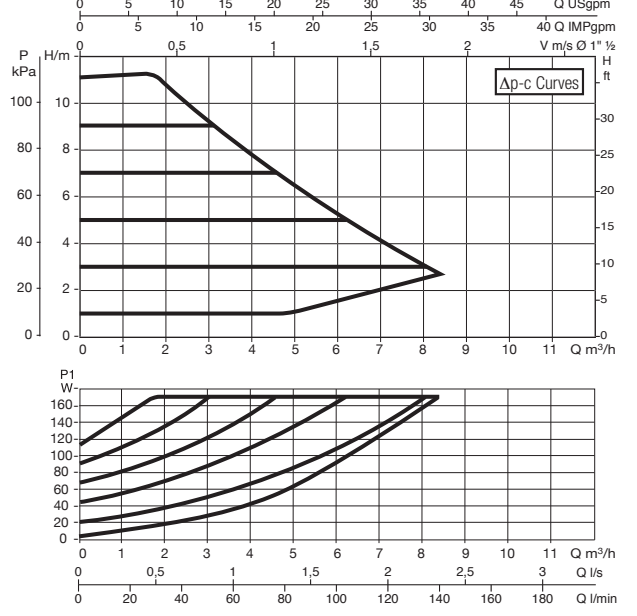
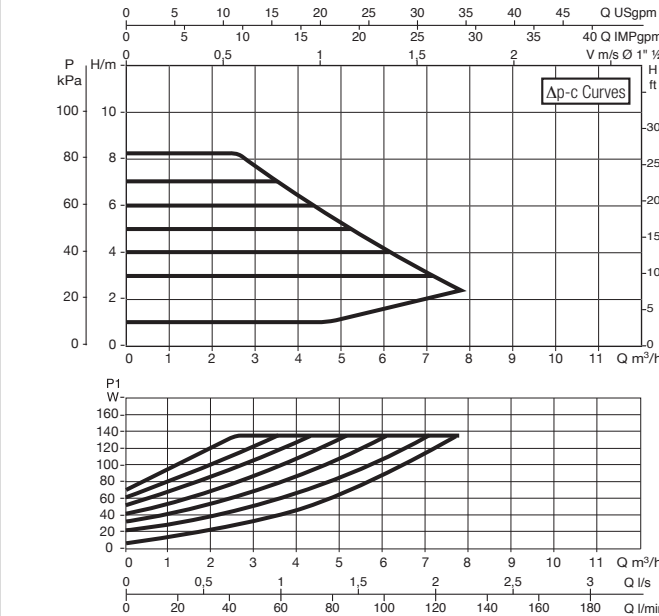
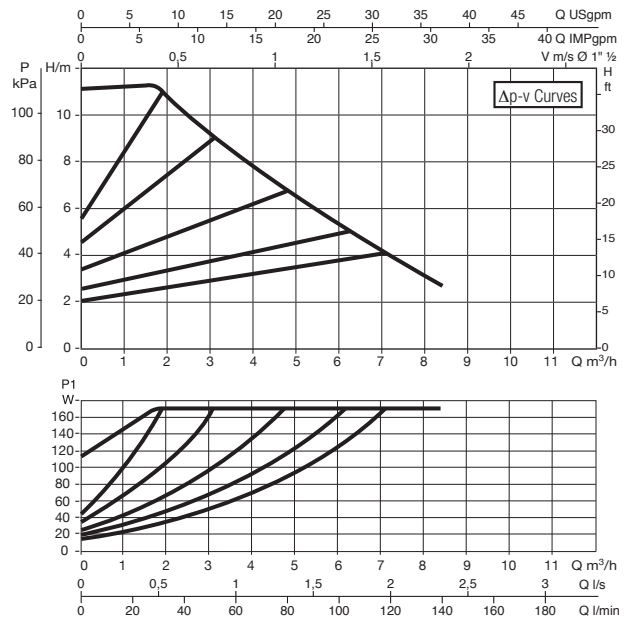

The curves are based on kinematic viscosity values = 1 mm²/s and density equal to 1000 kg/m³. Curve tolerance according to ISO 9906. Fixed speed curves available on the DNA.

MODEL	CENTRE DISTANCE mm	UNIONS ON REQUEST		COUNTERFLANGES ON REQUEST	POWER INPUT 50/60 Hz	P1 MAX W	In A	MINIMUM SUCTION PRESSURE			WEIGHT Kg
		STANDARDISED	SPECIAL					t°	90°	100°	
EVOPLUS 80/180 SAN M	180	1" F	1/2" F - 3/4" F	-	220/240 V	135	0,95	m.c.w.	20	25	4,5
EVOPLUS 110/180 SAN M	180	1" F	1/2" F - 3/4" F	-	220/240 V	170	1,16	m.c.w.	20	25	4,5

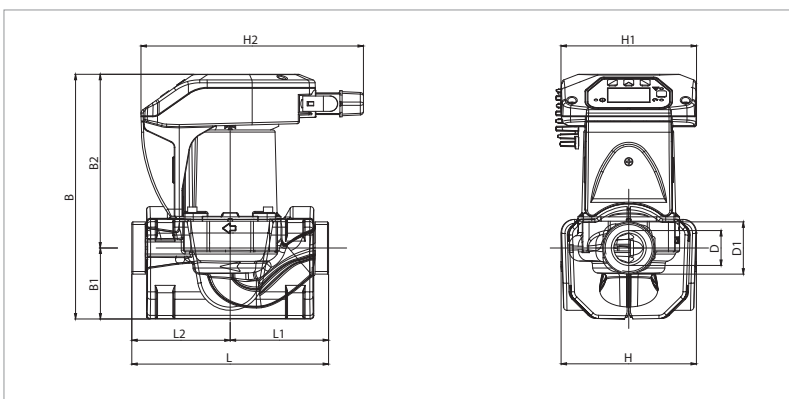

L	L1	L2	B	B1	B2	D	D1	H	H1	H2
180	90	90	224	65	159	32	1 1/2"	124	124	204

EVOPLUS SMALL SAN - WET ROTOR ELECTRONIC CIRCULATORS

Pumped liquid temperature range: from -10°C to +110 °C - Maximum operating pressure: 16 bar (1600 kPa)

EVOPLUS B 40/220.32 SAN M

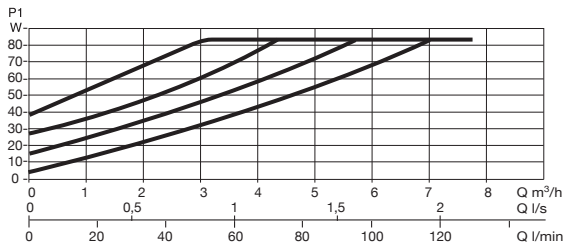
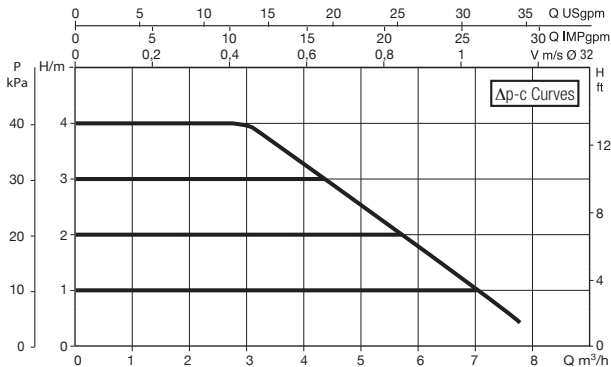
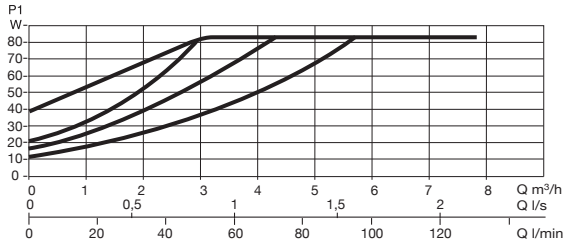
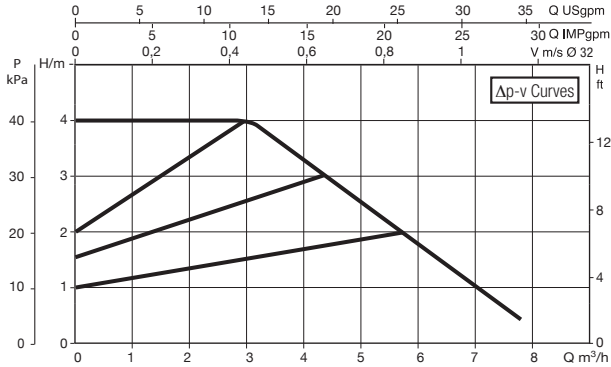

EVOPLUS B 60/220.32 SAN M

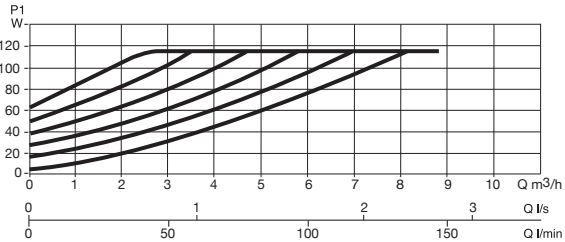
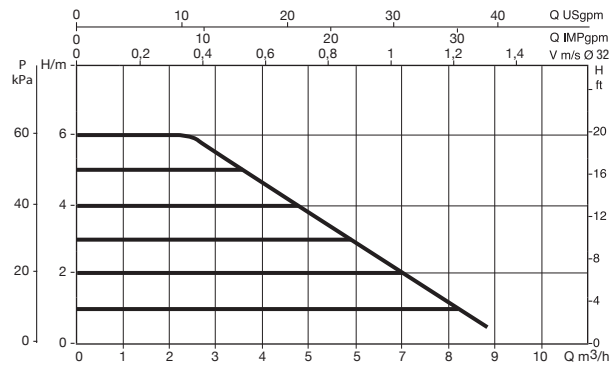
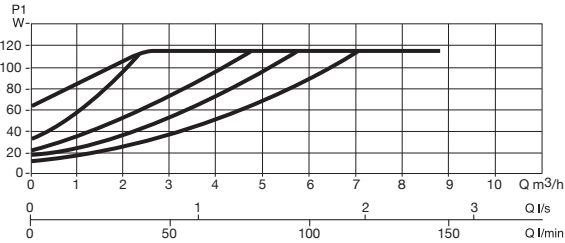
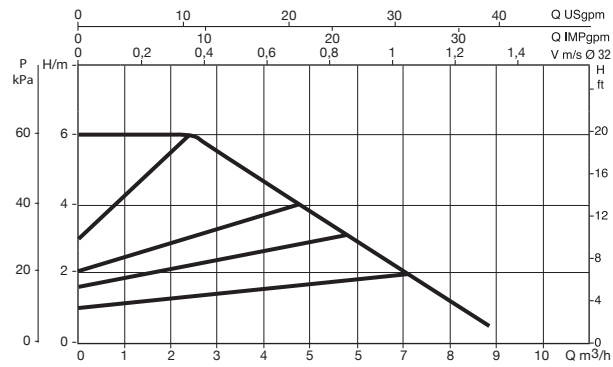

The curves are based on kinematic viscosity values = 1 mm²/s and density equal to 1000 kg/m³. Curve tolerance according to ISO 9906. Fixed speed curves available on the DNA.

MODEL	CENTRE DISTANCE mm	UNIONS ON REQUEST		COUNTERFLANGES ON REQUEST	POWER INPUT 50/60 Hz	P1 MAX W	In A	MINIMUM SUCTION PRESSURE			WEIGHT Kg
		STANDARDISED	SPECIAL					t°	90°	100°	
EVOPLUS B 40/220.32 SAN M	220	-	-	DN 32 PN 6	220/240 V	85	0,55	m.c.w.	20	25	8,6
EVOPLUS B 60/220.32 SAN M	220	-	-	DN 32 PN 6	220/240 V	110	0,75	m.c.w.	20	25	8,6

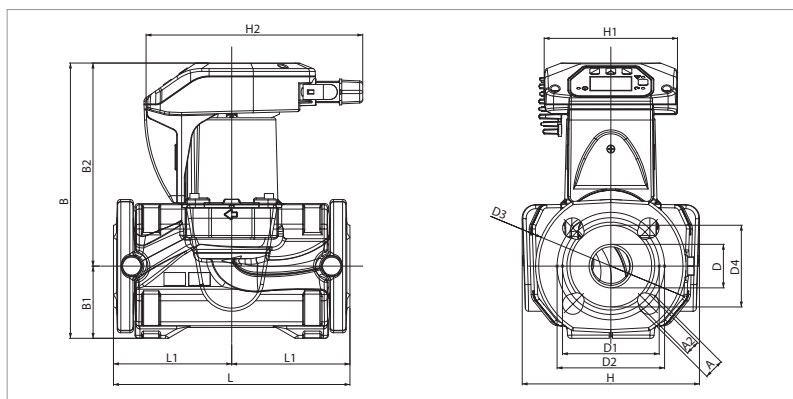

L	L1	L2	A	A2	B	B1	B2
220	110	110	19	14	256	67	189

D	D1	D2	D3	D4	H	H1	H2
40	90	100	140	76	165	124	204

EVOPLUS SMALL SAN - WET ROTOR ELECTRONIC CIRCULATORS

Pumped liquid temperature range: from -10 °C to +110 °C - Maximum operating pressure: 16 bar (1600 kPa)

EVOPLUS B 80/220.32 SAN M

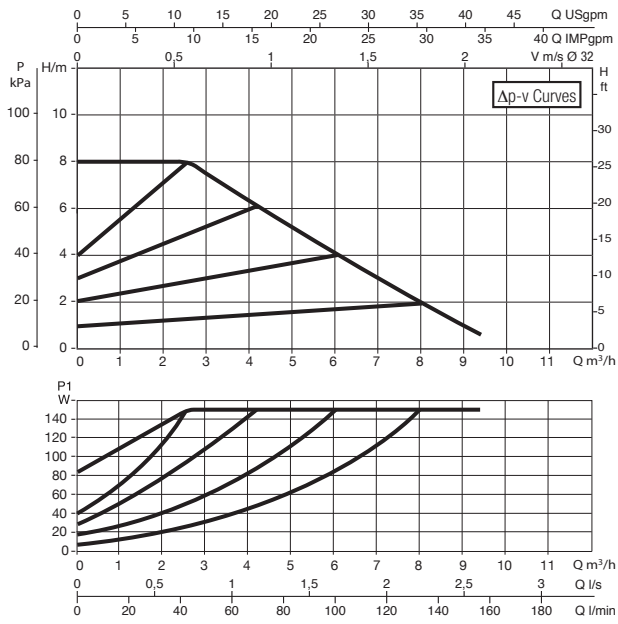

EVOPLUS B 110/220.32 SAN M

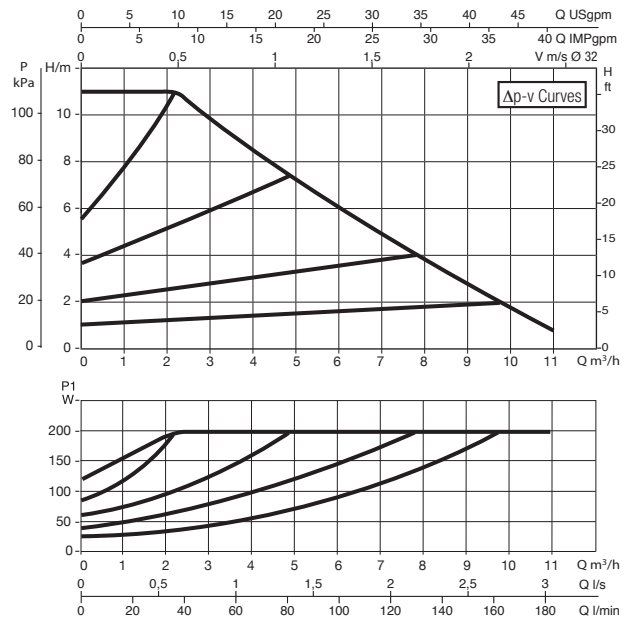

EVOPLUS B 80/220.32 SAN M

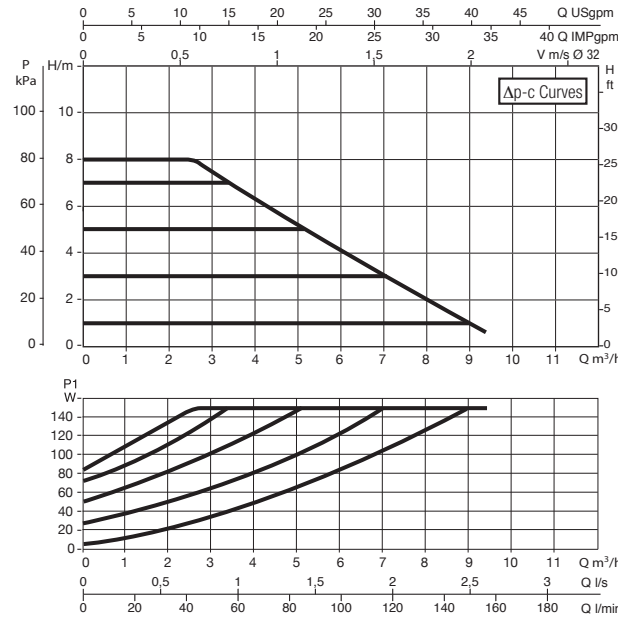

EVOPLUS B 110/220.32 SAN M

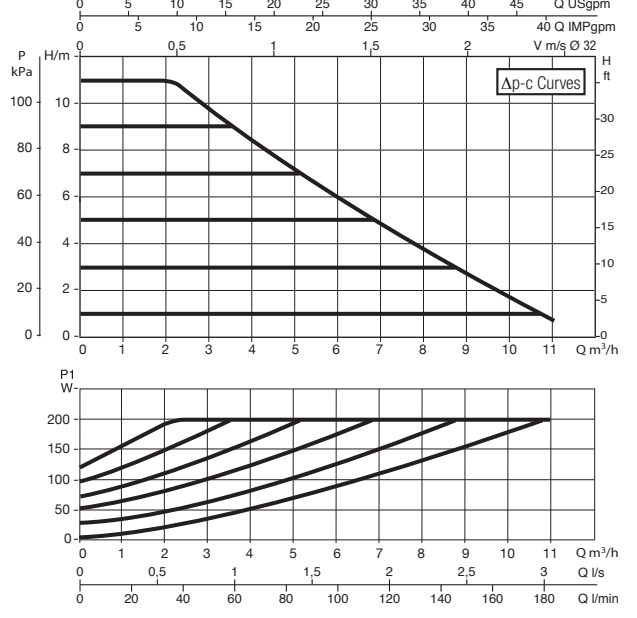

The curves are based on kinematic viscosity values = 1 mm²/s and density equal to 1000 kg/m³. Curve tolerance according to ISO 9906. Fixed speed curves available on the DNA.

MODEL	CENTRE DISTANCE mm	UNIONS ON REQUEST		COUNTERFLANGES ON REQUEST	POWER INPUT 50/60 Hz	P1 MAX W	In A	MINIMUM SUCTION PRESSURE			WEIGHT Kg
		STANDARDISED	SPECIAL					t°	90°	100°	
EVOPLUS B 80/220.32 SAN M	220	-	-	DN 32 PN 6	220/240 V	150	0,97	m.c.w.	20	25	8,6
EVOPLUS B 110/220.32 SAN M	220	-	-	DN 32 PN 6	220/240 V	200	1,3	m.c.w.	20	25	8,6

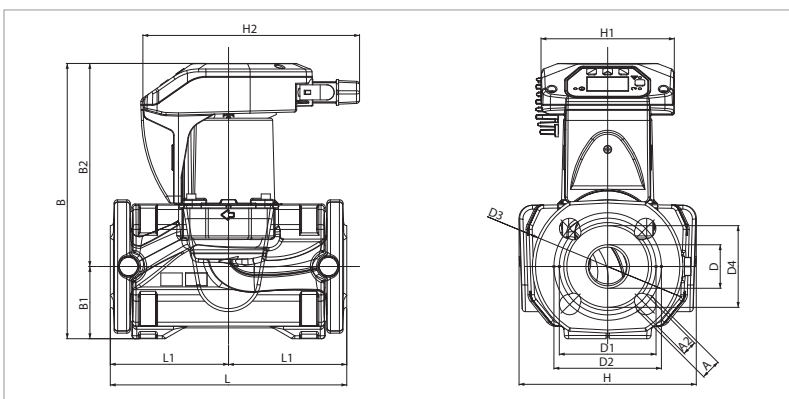

L	L1	L2	A	A2	B	B1	B2
220	110	110	19	14	256	67	189

D	D1	D2	D3	D4	H	H1	H2
40	90	100	140	76	165	124	204



EVOPLUS SMALL SAN - WET ROTOR ELECTRONIC CIRCULATORS

Pumped liquid temperature range: from -10 °C to +110 °C - Maximum operating pressure: 16 bar (1600 kPa)

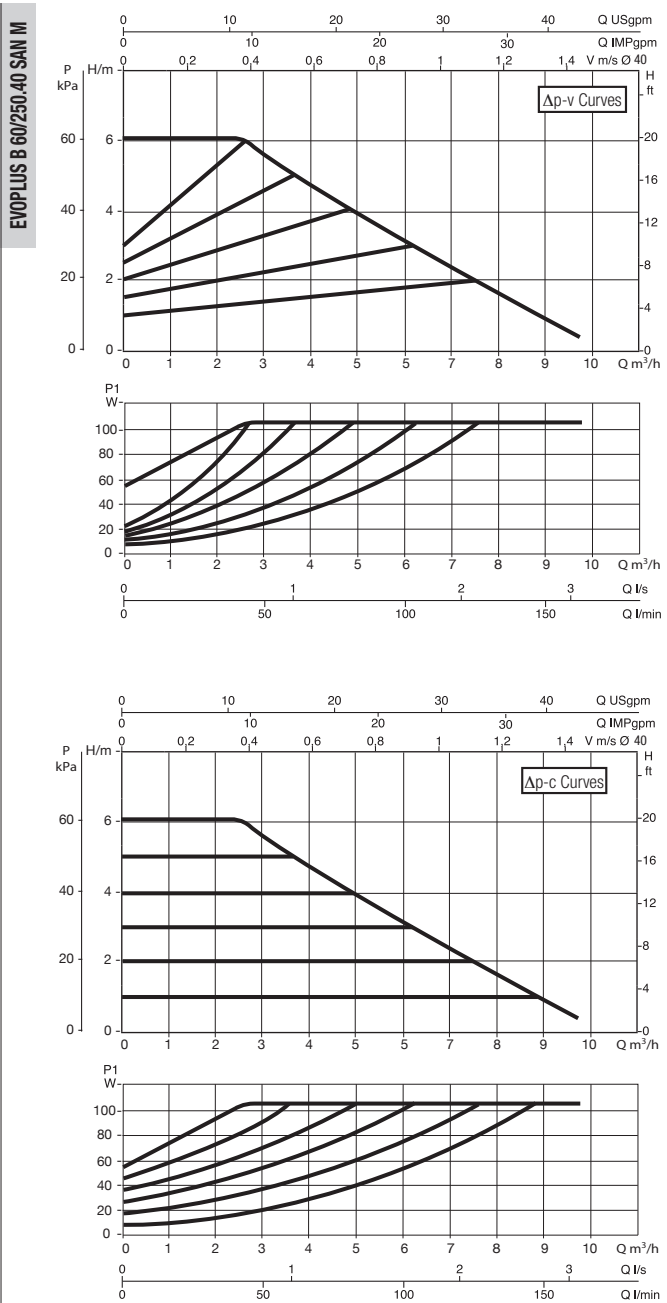
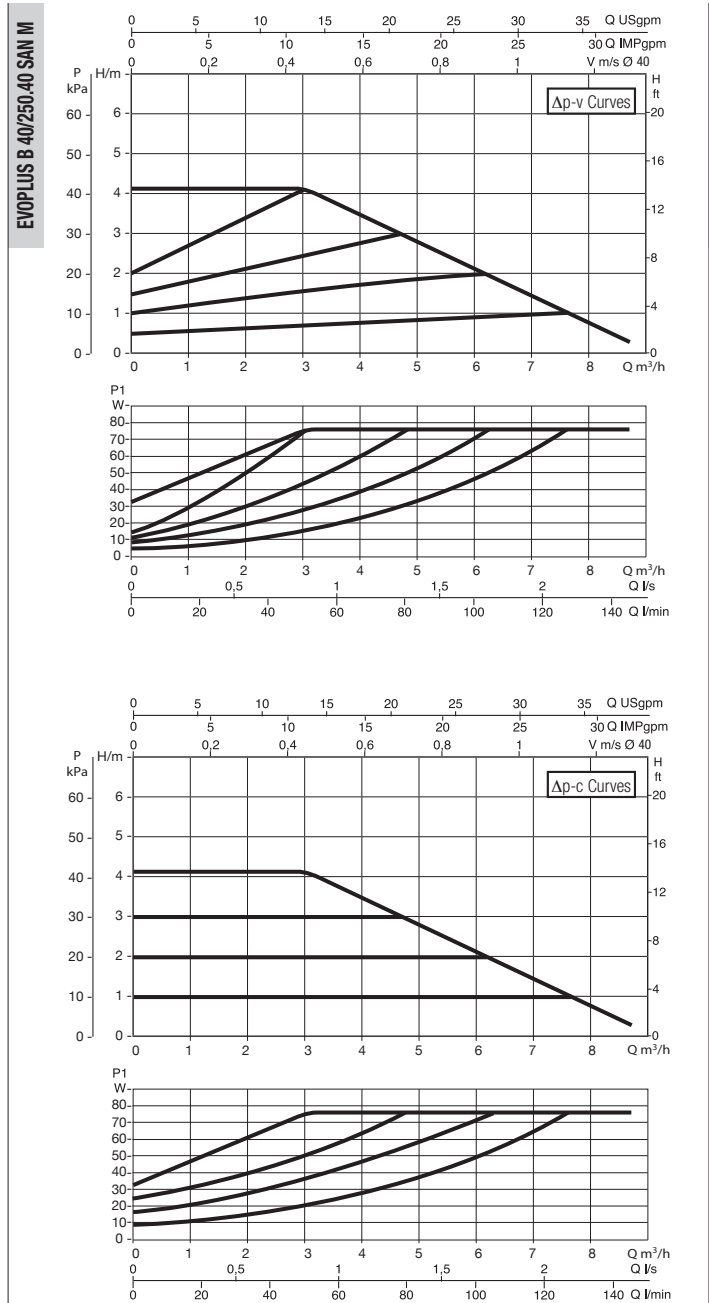

The curves are based on kinematic viscosity values = 1 mm²/s and density equal to 1000 kg/m³. Curve tolerance according to ISO 9906. Fixed speed curves available on the DNA.

MODEL	CENTRE DISTANCE mm	UNIONS ON REQUEST		COUNTERFLANGES ON REQUEST	POWER INPUT 50/60 Hz	P1 MAX W	In A	MINIMUM SUCTION PRESSURE			WEIGHT Kg
		STANDARDISED	SPECIAL					t°	90°	100°	
EVOPLUS B 40/250.40 SAN M	250	-	-	DN 40 PN 10	220/240 V	75	0,55	m.c.w.	20	25	9,3
EVOPLUS B 60/250.40 SAN M	250	-	-	DN 40 PN 10	220/240 V	105	0,75	m.c.w.	20	25	9,3

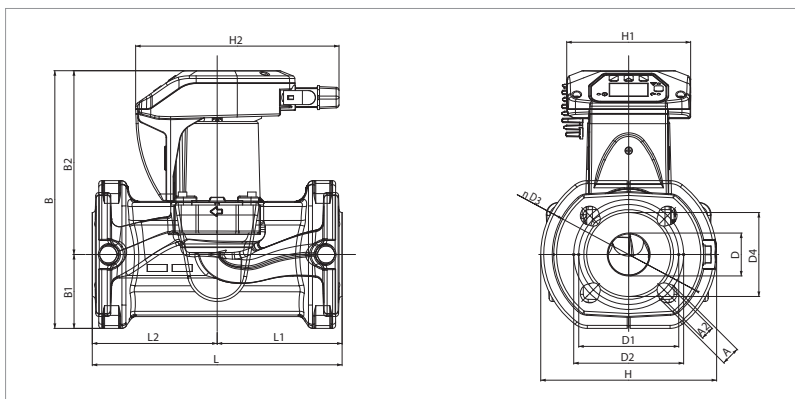

L	L1	L2	A	A2	B	B1	B2
250	125	125	19	14	258	74	184

D	D1	D2	D3	D4	H	H1	H2
43	100	110	150	84	176	124	204



EVOPLUS SMALL SAN - WET ROTOR ELECTRONIC CIRCULATORS

Pumped liquid temperature range: from -10 °C to +110 °C - Maximum operating pressure: 16 bar (1600 kPa)

EVOPLUS B 80/250.40 SAN M

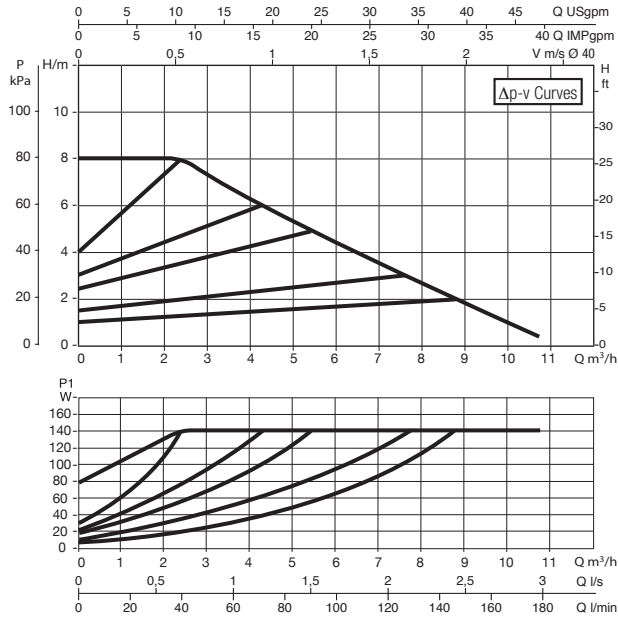

EVOPLUS B 110/250.40 SAN M

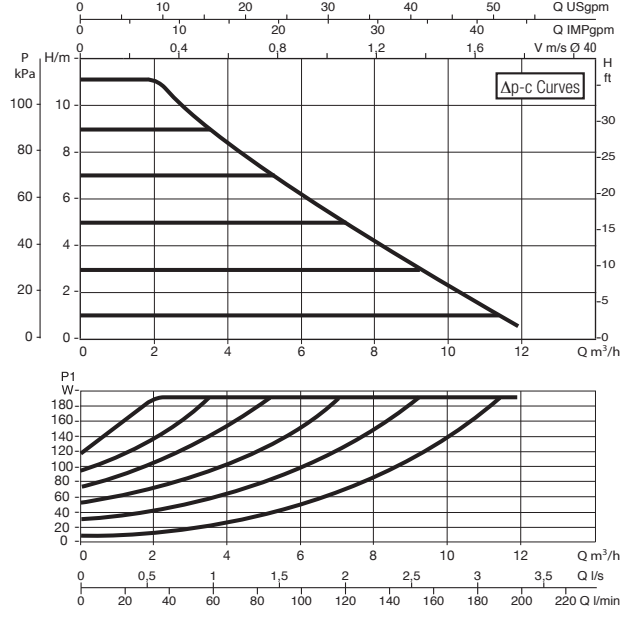
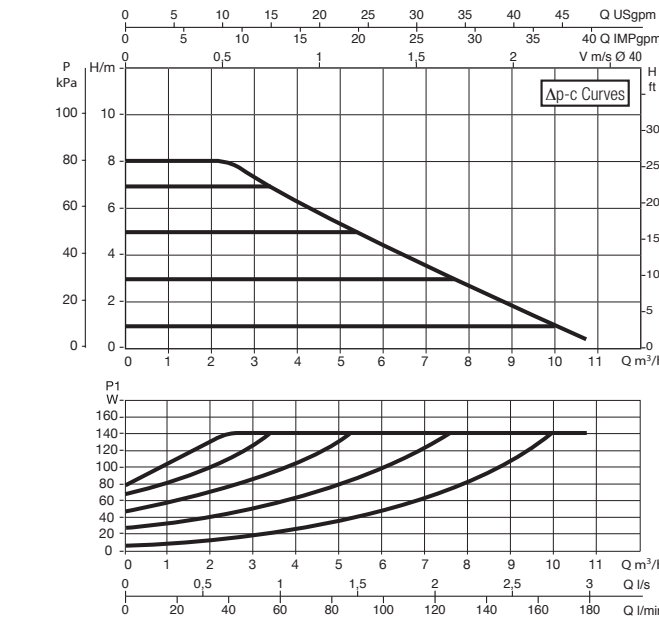
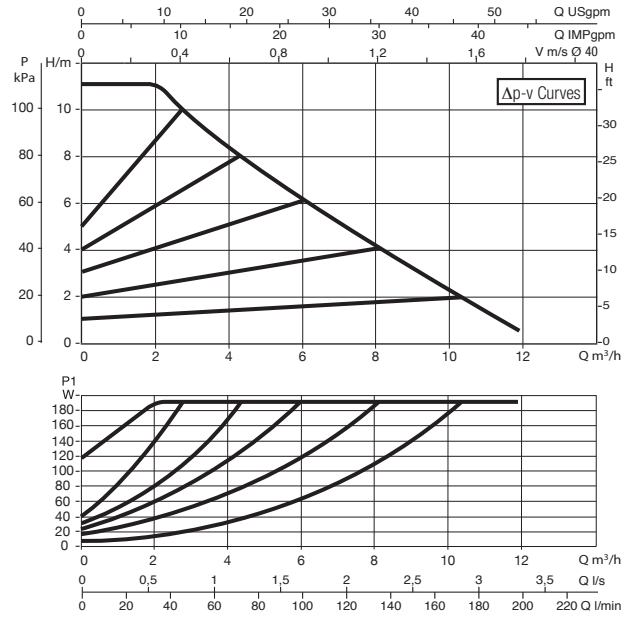

The curves are based on kinematic viscosity values = 1 mm²/s and density equal to 1000 kg/m³. Curve tolerance according to ISO 9906. Fixed speed curves available on the DNA.

MODEL	CENTRE DISTANCE mm	UNIONS ON REQUEST		COUNTERFLANGES ON REQUEST	POWER INPUT 50/60 Hz	P1 MAX W	In A	MINIMUM SUCTION PRESSURE			WEIGHT Kg
		STANDARDISED	SPECIAL					t°	90°	100°	
EVOPLUS B 80/250.40 SAN M	250	-	-	DN 40 PN 10	220/240 V	140	0,97	m.c.w.	20	25	9,3
EVOPLUS B 110/250.40 SAN M	250	-	-	DN 40 PN 10	220/240 V	190	1,3	m.c.w.	20	25	9,3

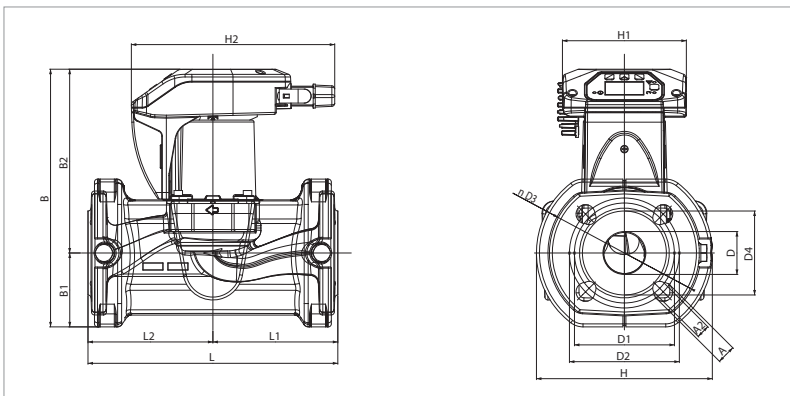

L	L1	L2	A	A2	B	B1	B2
250	125	125	19	14	258	74	184

D	D1	D2	D3	D4	H	H1	H2
43	100	110	150	84	176	124	204

EVOPLUS / EVOPLUS SAN

WET ROTOR ELECTRONIC CIRCULATORS



EVOPLUS

EVOPLUS SAN

TECHNICAL DATA

Operating range: from 3 a 75.6 m³/h with head of up to 18 metres.

Pumped liquid temperature range: from -10 °C to +110 °C.

Pumped liquid: clean, free of solids and mineral oils, non-viscous, chemically neutral, with properties similar to water. (glycol max 30%).

Maximum operating pressure: 16 bar (1600 kPa).

Standard flanges: DN 32, DN 40, DN 50, DN 65, PN 6 / PN 10 / PN 16 (4 holes), DN 80 and DN 100, PN 6 (4 holes).

Maximum ambient temperature: + 40 °C.

Minimum suction pressure: the values are shown in the corresponding tables.

Special executions on request: DN 80, DN 100 PN 10 / PN 16 (8 holes).

Accessories (Counter flanges): PN 10 DN 32 - DN 40 - DN 50 - DN 65
PN 6 DN 80 - DN 100.

Electromagnetic compatibility: EVOPLUS circulator comply with EN 61800-3 standard, category C2, as far as electromagnetic compatibility.

Electromagnetic emissions - Residential environment (containment measures might be required in some cases).

Conducted emissions - Residential environment (containment measures might be required in some cases).

APPLICATIONS

EVOPLUS circulation electronic pumps can be used in heating, ventilation, and air conditioning systems for residential and commercial buildings, like:

- Large residential buildings
- Private and public hospitals
- Real estate buildings
- Condominiums and small apartment buildings
- Schools
- Homes
- Office buildings

All the models are available both in the single and twin version.

Bronze pump execution for the recirculation of sanitary water, available in single version with DN 32, DN 40, DN 50 and DN 65 flanged ports.

Supplied as a standard ready for control using 0-10 V or PWM external signal, and for the connection to ModBus management systems (LonBus with appropriate communication module available as optional). **You can remotely control the single version thanks to the Dconnect service** (with Dconnect Box provided separately).

HEATING SYSTEM APPLICATIONS

The heating required for the different applications varies significantly during day and night, due to the external temperature, or the degree of occupancy inside the areas. To the above, one must add the different needs of the various environments, and the opening or closing of the various circuit branches of complex systems. Electronic wet rotor pumps ensure at all times, and virtually in all correctly sized systems, a sufficient level of energy, together with a quieter operation, and more comfort, together with an important reduction of operating costs.

AIR CONDITIONING APPLICATIONS

Unlike conventional electronic pumps, EVOPLUS electronic circulators can also be used in air conditioning systems where the temperature of the pumped liquid is lower than the room temperature. In these conditions, condensation tends to form on the outer surface of the circulator, which however does not affect the operation of the electronic and the mechanical components. The unit is designed and sized in such a way that it allows condensation to drain without damage to the construction components.

SANITARY RECIRCULATION APPLICATIONS

The SAN version, with bronze pump body, was specifically developed for the recirculation of sanitary water. With the constant temperature mode of operation, the temperature inside the recirculation piping is controlled without the need for thermostat valves, therefore optimizing comfort.

CONSTRUCTION FEATURES

Monobloc circulation pump consisting of the cast iron hydraulic section, and the wet rotor synchronous motor. Aluminium motor casing. Scroll type pump body featuring high hydraulic efficiency thanks to highly precise design and smooth internal surfaces. In-line suction and delivery ports.

The single version is supplied as standard with insulating casing, to avoid heat dispersion and/or the formation of condensation on the pump body.

For the twin version, the insulation must be provided by the installer. In any case, pay attention not to obstruct the condensation drainage ducts, to avoid impairing the operation of the circulator.

Technopolymer impeller, stainless steel motor shaft on ceramic bushings lubricated by the pumped liquid. Stainless steel rotor protection liner. Ceramic thrust ring, ethylene-propylene seal rings and carbon fibre composite stator liner. Asynchronous motor with permanent magnet rotor. The twin version features an automatic swing check valve incorporated in the delivery port, to avoid water recirculating through the unit when this is not running; in addition, a blank flange is also supplied as standard, to allow either of the two motors to be removed for servicing. The standard execution of the pump body is PN 16. DN 80 and DN 100 PN 16 (8 holes) also available on request.

Circulator protection class: IP X4D

Insulation class: F

Standard voltage: single-phase 220/240 V / 50/60 Hz

sound pressure value \leq 45 dB(A)

Product compliant with European Standards EN 61800-3 – EN 60335-1 – EN 60335-2-51

DCONNECT SERVICE

REMOTE CONTROL FOR ELECTRONIC RESIDENTIAL AND COMMERCIAL SYSTEMS

The Dconnect service offers simple and intuitive remote control of your installation, without the need of a server or specialist personnel.

With Dconnect, you can remotely manage your installations as if you were right in front of them.

Thanks to the system operation charts, you will also be able to optimise operation. You will also receive prompt notifications of any system faults.

THE CONNECTIVITY SERVICE ALLOWS YOU TO:

EASILY MONITOR YOUR SYSTEMS

The installations with green status are OK, while the orange ones need attention, and the red ones are experiencing problems

The screenshot shows the 'Installation list' section of the DCONNECT web interface. It features a grid of eight installation cards, each with a computer monitor icon and a 'STATUS' indicator with a green checkmark. The installations listed are:

- Impianto di pressurizzazione via Cairoli Pisa
- Condominio Cancelli Palaia
- Condominio Pero Livorno
- Condominio Nicolai Firenze
- Officine Arnoldi Pressurizzazione
- Officine Arnoldi Riscaldamento
- Officine Arnoldi Acqua Calda Sanitaria
- Officine Arnoldi gruppi frigo

TAKE ANY NECESSARY ACTIONS AS IF YOU WERE RIGHT IN THE PUMP ROOM

Using the internet site or the APPs, you will be able to easily and quickly control your systems.

The screenshot shows the detailed control interface for a pump. At the top, it displays the 'DCONNECT' logo and a network diagram. Below this, there is a product image of the pump and the following information:

- NAME : **EVOPLUS**
- PRODUCT DESCRIPTION : **EVOPLUS**
- SERIAL : **R631K**
- Time elapsed from last received data **less than 3m**

A 'Status' dropdown menu is set to 'Status'. Below this, there is a grid of monitoring cards:

- SYSTEM ERROR STATUS**: System OK (with a warning icon)
- HEAD**: 11.1 m (with a gear icon)
- PUMP STATUS**: Off (with a power icon)
- ESTIMATED FLOW**: 11.3 m³/h (with a flow icon)
- POWER**: 0 W (with a power icon)
- RPM**: 0 rpm (with a speedometer icon)
- CURRENT**: 0 mA (with a current icon)
- RUN TIME PUMP**: 16968 h (with a clock icon)
- BOARD TEMPERATURE**: -°C (with a temperature icon)
- LIQUID TEMPERATURE**: 16 °C (with a liquid temperature icon)
- LIQUID TEMPERATURE 2**: -°C (with a liquid temperature icon)
- HEATSINK TEMPERATURE**: 29 °C (with a heatsink icon)
- LINE VOLTAGE**: 228 V (with a voltage icon)

DCONNECT SERVICE

REMOTE CONTROL FOR ELECTRONIC RESIDENTIAL AND COMMERCIAL SYSTEMS

In order to use the Dconnect service, registration and connected products are required.

Connect to the website: <https://dconnect.dabpumps.com>, using Internet Browsers such as Microsoft Edge or Google Chrome.

The Android and iOS Dconnect APPs can be downloaded from the relevant Stores:



REMOTE ALARMS

In case of alarm, the Dconnect service will promptly send you a notification, so that you can check what is happening and organise a visit to the system before the issue becomes an emergency for your customer.

WHAT PRODUCTS CAN YOU MANAGE USING THE DCONNECT SERVICE?

MCE/P, MCE/C, ADAC, Active driver Plus, Ebox, Evoplus, Eskybox, Eskybox mini, Eskybox Diver, Dtron 3.

WHAT DO YOU NEED TO USE THE SERVICE?

1. DConnect Box
2. Cables for the connection of the DConnect Box / Dconnect Box 2 to the products to control
3. One or more compatible products
4. An internet connection in the system to control

For more information visit: internetofpumps.com

EVOPLUS / EVOPLUS SAN

WET ROTOR ELECTRONIC CIRCULATORS

EVOPLUS CONSTRUCTION CHARACTERISTICS COLLECTIVE SYSTEMS (ELECTRONIC DEVICE)*

EVOPLUS circulators are controlled by a latest generation NPT technology IGBT device, for better efficiency and strength. The specific features are:

- Sine-wave PWM modulation
- High carrier frequency to eliminate all audio band noise
- 2 dedicated 32 bit processors
one for driving the motor
one for the user interface, enabling to perform the following functions:
 - start/stop command
 - Economy command
 - 0-10 V analogue signal command
 - PWM signal command
 - 4-20 mA analogue signal command
 - ΔT temperature sensor signal command
- connection to ModBus system management devices. Optional LonBus with appropriate module.
- Optimised "space vector" algorithm
- Presence/absence of system alarms
- Pump in operation notification

* Inputs only available if the associated function is active.

An intuitive and functional user interface guarantees ease of calibration by all users. The easy to read OLED display on the control panel, three simple navigation keys, an in-line cascade menu featuring the latest mobile technology trends, and a wide range of functions, mean that EVOPLUS circulators are truly revolutionary products. A reliable and sturdy construction, together with a modern and innovative design, complete the product, also in terms of aesthetic value.

MATERIALS

N.	PARTS	MATERIALS
1	PUMP BODY	CAST IRON 250 UNI ISO 185 - CTF BRONZE (for the SAN version)
4	IMPELLER	TECHNOPOLYMER
7A	MOTOR SHAFT	STAINLESS STEEL
7B	ROTOR	STAINLESS STEEL LINER
8	STATOR	-
10	MOTOR CASING	DIE-CAST ALUMINIUM
127	SEAL RING	EPDM RUBBER
128	STATOR LINER	COMPOSITE AND CARBON FIBRE
130	CLOSING FLANGE	STAINLESS STEEL
131	THRUST RING SUPPORT	STAINLESS STEEL
132	BUSHINGS	ALLUMINA

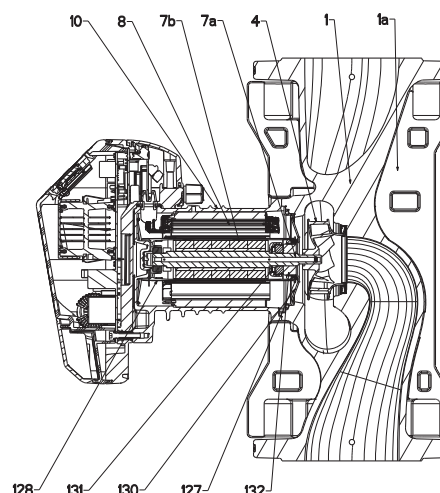

- Legend:
(example)

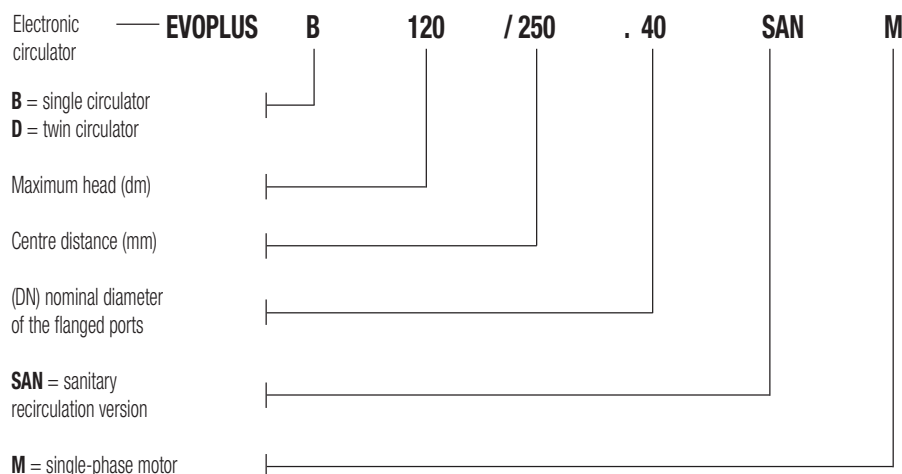

EVOPLUS / EVOPLUS SAN

WET ROTOR ELECTRONIC CIRCULATORS

MODES OF OPERATION

All the functions listed below can be consulted by the users (including less experienced ones) by simply scrolling through the menu. The calibration and the modification of the parameters are protected, and can only be completed by expert users. The factory settings of the EVOPLUS range are for proportional differential pressure control mode in the curve that ensures the best energy efficiency index (EEI).

1 - ΔP -v proportional differential pressure adjustment mode

With ΔP -v adjustment mode, with the variation of the flow rate, the value of the delivery of the head also varies in a linear manner, from H_{setp} to $H_{setp}/2$.

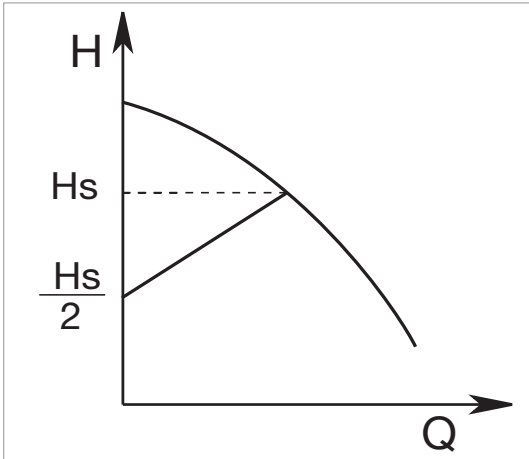

This adjustment is particularly indicated for the following systems:

a. Two-pipe heating systems with thermostat valves and with:

- head greater than 4 metres;
- very long circuit piping;
- valves with wide operating range;
- differential pressure regulators;
- high pressure drops in those parts of the system carrying the entirety of the water flow rate;
- low differential pressure.

b. Under-floor central heating systems with thermostatic valves and significant pressure drops in the boiler circuit.

c. Systems with primary circuit pumps with high pressure drops.

Example of set-up of the set-point with ΔP -v

The following operating point is required:

$$Q = 6,5 \text{ m}^3/\text{h}$$

$$H = 6 \text{ m}$$

PROCEDURE:

1. In the graph, find the desired operating point, and then find the EVOPLUS curve closest to it (in this case the point lies precisely on the curve)
2. Follow the curve upwards until reaching the intersection with the limit curve of the circulator.
3. The head reading at this limit point is the set-point head that must be entered to obtain the desired operating point.

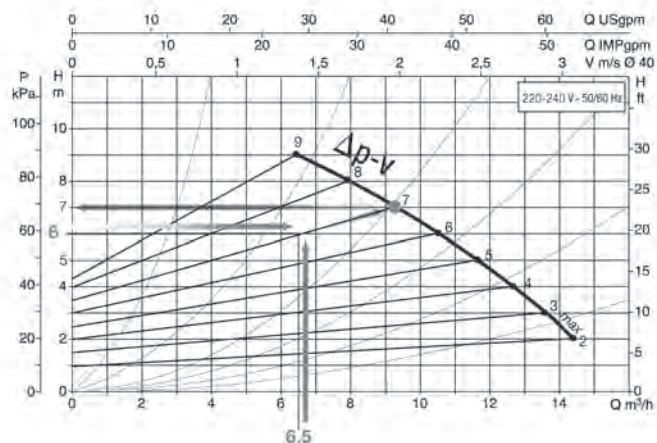

2 - ΔP -c constant differential pressure adjustment mode

The ΔP -c adjustment mode keeps the differential pressure of the system constantly at the H_{setp} value set, even in case of variation of the flow rate.

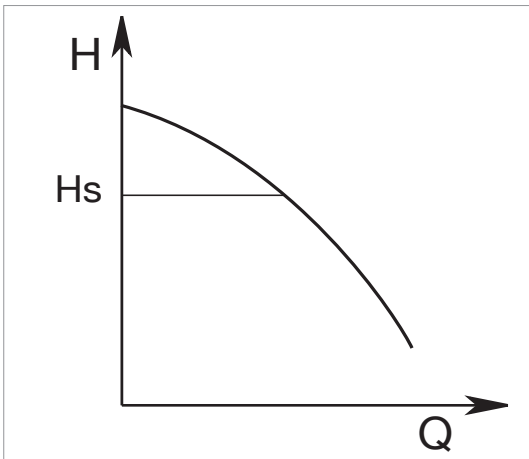

This adjustment is particularly indicated for the following systems:

a. Two-pipe heating systems with thermostat valves and with:

- head lower than 2 metres;
- natural circulation;
- low pressure drops in those parts of the system carrying the entirety of the water flow rate;
- high differential temperature (central heating).

b. underfloor heating systems with thermostat valves

c. single-pipe heating systems with thermostat valves and calibration valves

d. Systems with primary circuit pumps with low pressure drops.

3 - Constant curve adjustment modes

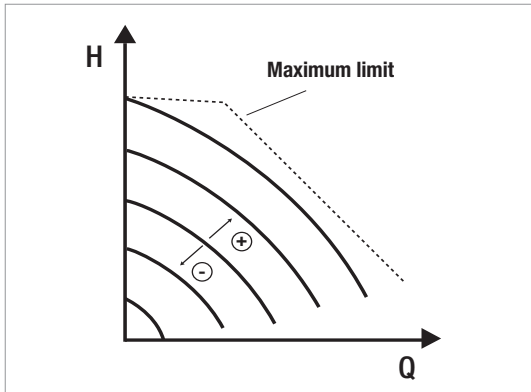

In this control mode, the circulator works based on constant speed characteristic curves. The operation curve is selected by setting the rotation speed using a percentage factor. The 100 % value indicates the maximum limit curve. The actual rotation speed may be affected by the power and differential pressure limitations of the actual circulator model. The rotation speed may be set using the display, or either a 0-10 V or PWM external signal.

Control mode indicated for constant flow rate heating and air conditioning systems.

4 - Constant differential pressure control mode with proportional control based on the water temperature

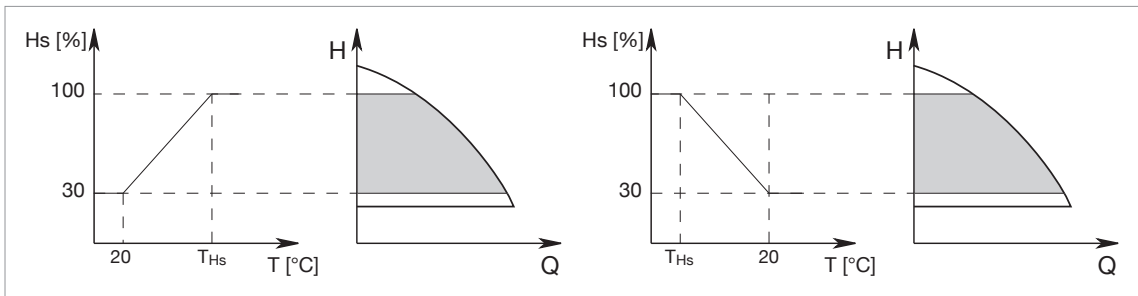

The circulator head set-point is reduced in accordance with the water temperature. The liquid temperature can be set between 0 °C to 100 °C.

This adjustment is particularly indicated for the following systems:

- in variable flow rate systems (two-pipe central heating systems), for which a further reduction of the circulator performance levels is provided in accordance with the lowering of the temperature of the circulating liquid, in case of reduced heating demand.
- in constant flow rate systems (single-pipe and under-floor central heating systems), where the performance of the circulator can only be adjusted by activating the temperature influence function. It is set through the EVOPLUS control panel.

5 - ΔT -c * constant differential temperature adjustment mode

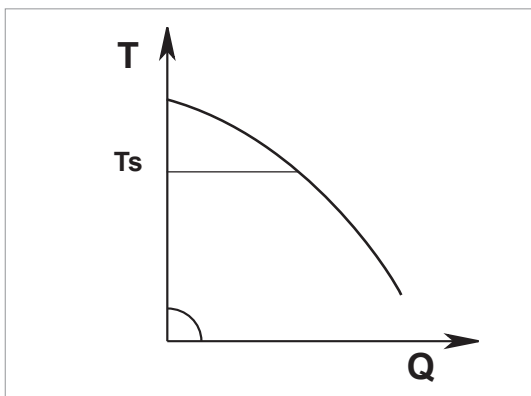

The ΔT -c control mode keeps the pumped liquid at constant temperature, changing the flow rate to the Tsetp settable value.

This adjustment is particularly indicated for the following systems:

- Under-floor heating systems.
- Systems with circuit pumps with heat exchanger.
- Solar energy systems with storage tanks.
- Solar panel swimming pool heating systems.

* Adjustment during implementation.

ECONOMY MODE

The economy function can be set directly on the control panel, by setting a reduction value (f.rid), the maximum value of which can be 50%. In all the previously listed settings, the Hset value must be replaced with an Hset x f.rid.

EVOPLUS / EVOPLUS SAN

WET ROTOR ELECTRONIC CIRCULATORS

CONNECTION DIAGRAM

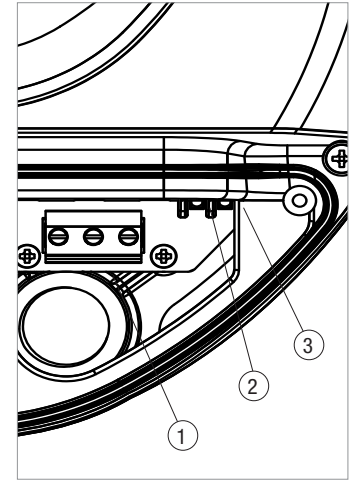
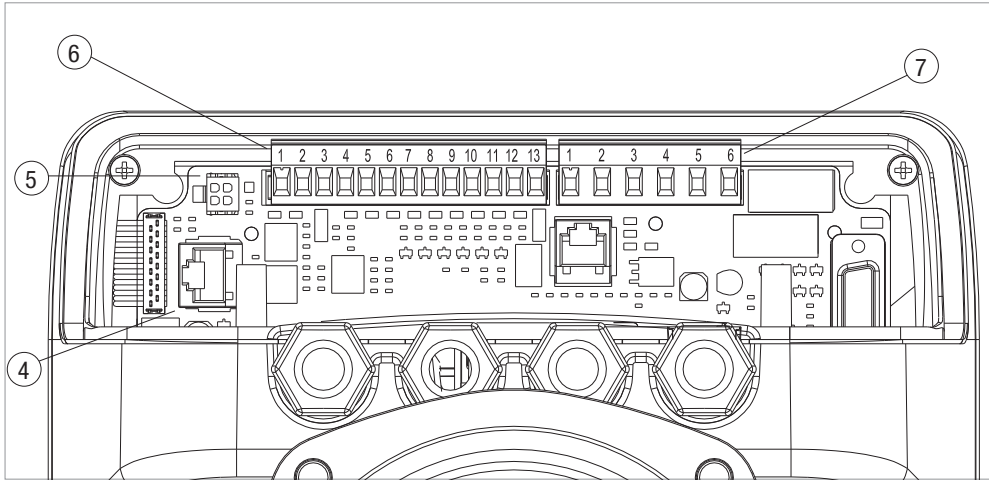

1	Removable terminal box for the connection of the power input line: 1x220-240 V, 50/60 Hz
2	Auxiliary LED
3	High voltage LED
4	Connector for twin circulators
5	Connector for pressure and temperature sensor on the circulator (as standard)
6	Removable 13-pole terminal box for the connection of MODBUS systems and inputs
7	Removable 6-pole terminal box for system status and alarm notification

POWER INPUT CONNECTION

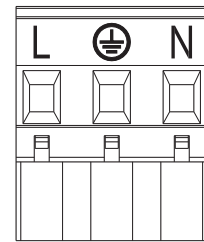

Removable power input terminal box

USER INTERFACE

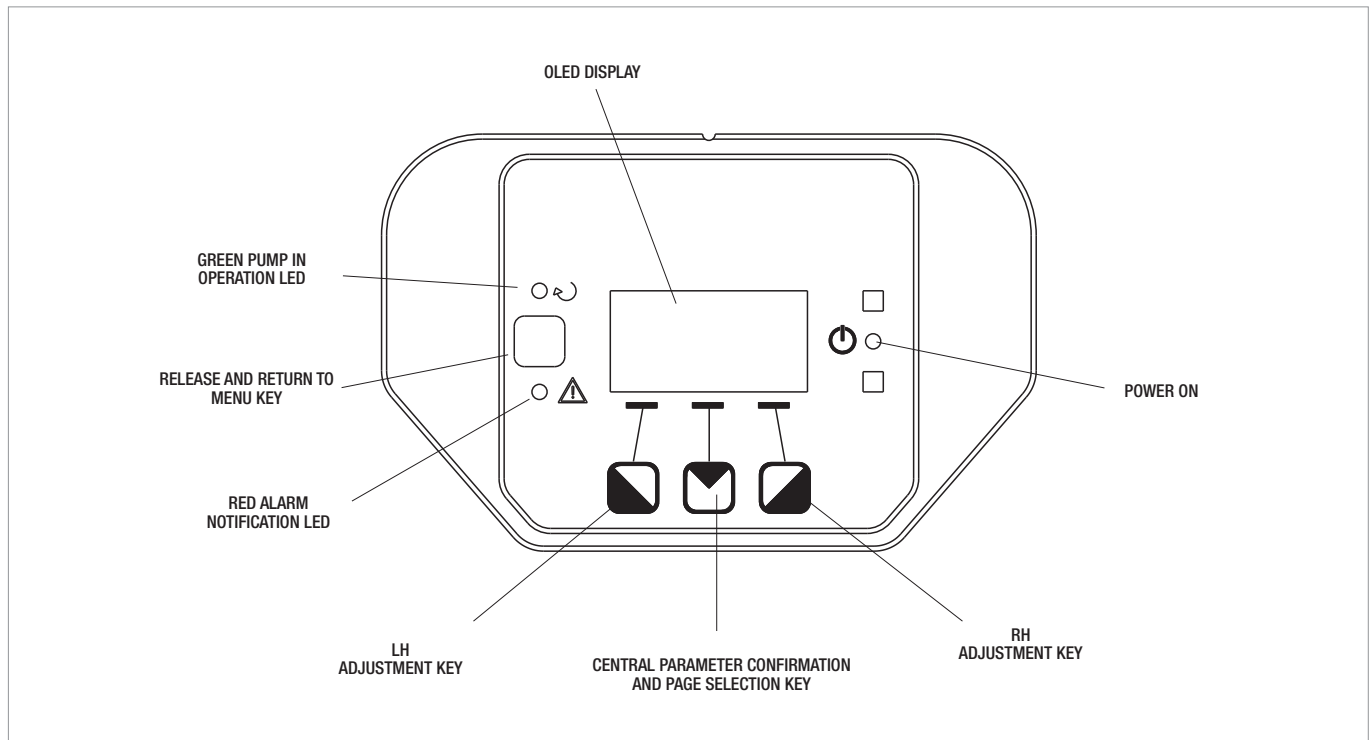

EVOPLUS / EVOPLUS SAN

WET ROTOR ELECTRONIC CIRCULATORS

Digital inputs

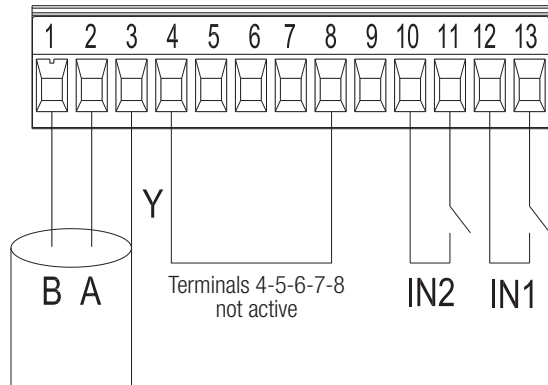

Input	Terminal no.	Type of contact	Associated function
IN1	12	Clean contact	EXT: If it is activated from the control panel, it will be possible to remotely control the switching on and off of the pump.
	13		
IN2	10	Clean contact	Economy: If it is activated from the control panel, it will be possible to remotely activate the set-point reduction function.
	11		

If the **EXT** and **Economy** functions have been activated using the control panel, the system will behave as follows:

IN1	IN2	System status
Open	Open	Pump stopped
Open	Close	Pump stopped
Close	Open	Pump in operation with set-point set by the user
Close	Close	Pump in operation with reduced set-point

MODBUS

EVOPLUS circulators provide serial communication through an RS-485 input. The communication is established in accordance with the MODBUS specifications. Using the MODBUS, it is possible to remotely set the circulator operating parameters, like the desired differential pressure, the temperature influence, the control mode, etc. At the same time, the circulator can provide important information on the status of the system.

Modbus terminals	Terminal no.	Description
A	2	Terminal not inverted (+)
B	1	Terminal inverted (+)
Y	3	GND

LONBUS

Using some modules available on the market, the circulator, and therefore its status, can also be made available to a LonWorks network. It will then be possible to change the parameters of the circulator by reading and amending the registers as indicated in the "Modbus Protocol instruction manual", available at the following address: "<http://www.dabpumps.it/evoplus>".

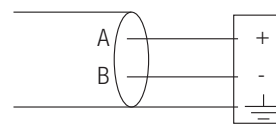

Gateway/ Evoplus connection

ANALOGUE AND PWM INPUT

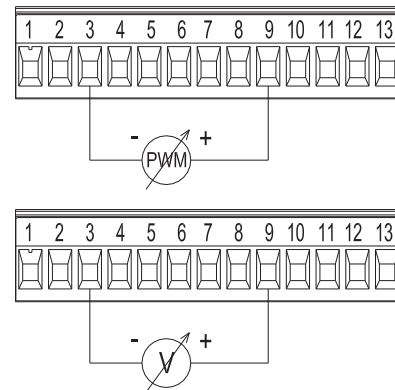

Connection diagram for the external 0-10 V and PWM signals. The 2 signals share the same terminals of the terminal box, and therefore are mutually exclusive.

Digital outputs

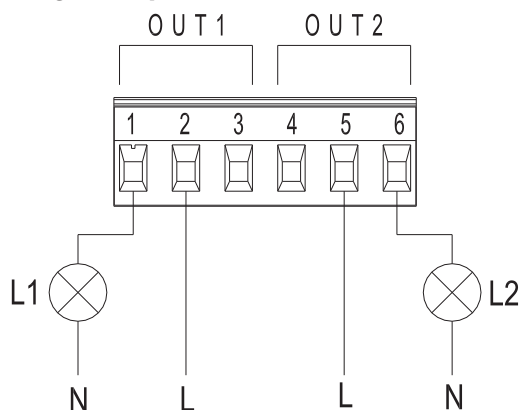

Light L1 comes on when the system includes an alarm, and goes off when no faults are detected, while light L2 comes on when the pump is in operation, and goes off when the pump is stopped.

OUTPUT	TERMINAL NO.	TYPE OF CONTACT	ASSOCIATED FUNCTION
OUT1	1	NC	Presence/absence of system alarms
	2	COM	
	3	NO	
OUT2	4	NC	Pump in operation/Pump stopped
	5	COM	
	6	NO	

Outputs OUT1 and OUT2 are available on the 6-pole removable terminal box, where the type of contact is also shown (NC = Normally Closed, COM = Common, NO = Normally Open).

CHARACTERISTICS OF THE OUTPUT CONTACTS

Max sustainable voltage [V]	250
Max sustainable current [A]	5 - If resistive load 2,5 - If inductive load
Max cable section accepted [mm ²]	1,5

EVOPLUS RANGE

WET ROTOR ELECTRONIC CIRCULATORS

PERFORMANCE RANGE

The performance curves are based on kinematic viscosity values = 1 mm²/s and density equal to 1000 kg/m³. Curve tolerance according to ISO 9906.

GRAPHIC SELECTION TABLE

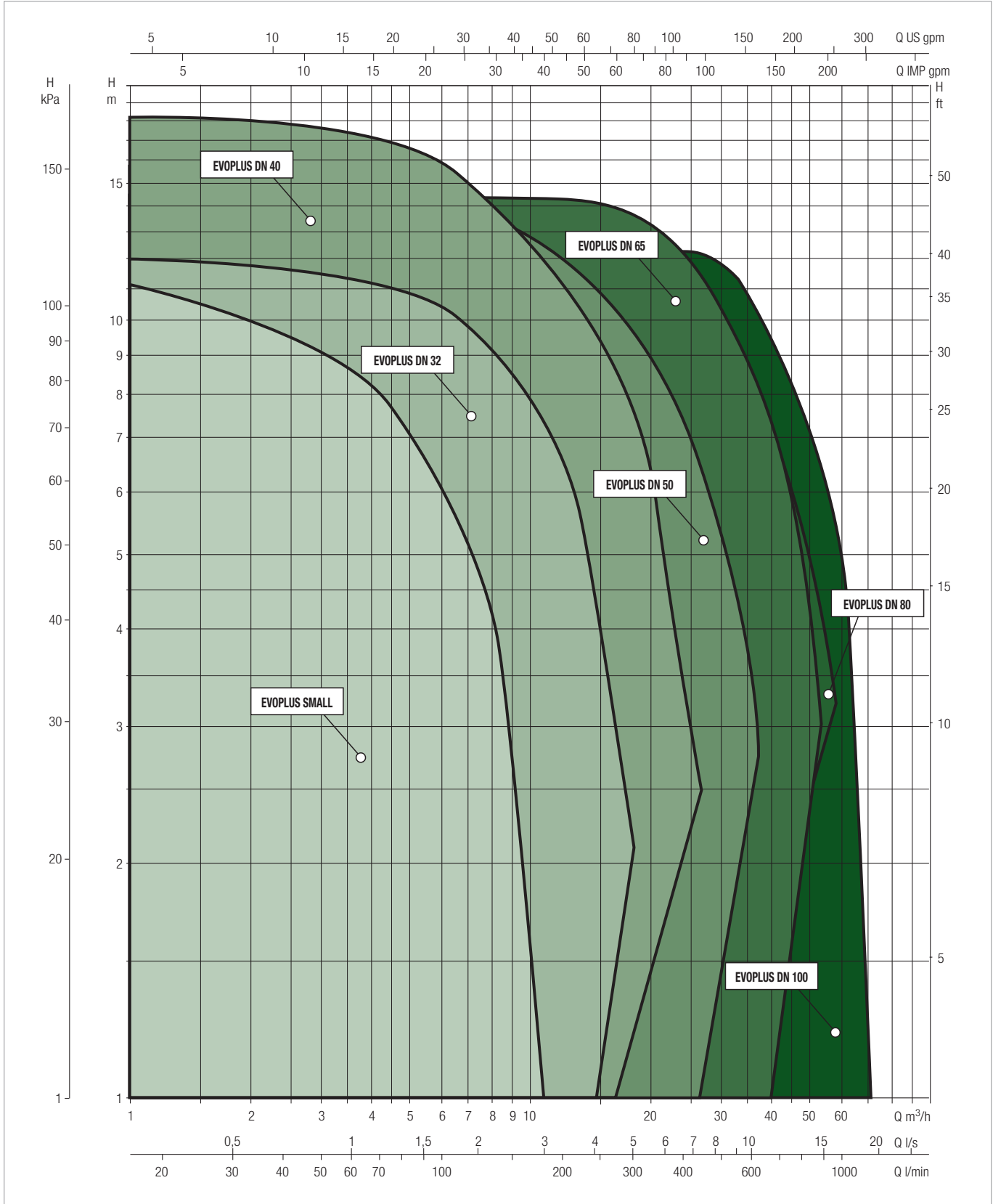

EVOPLUS / EVOPLUS SAN

WET ROTOR ELECTRONIC CIRCULATORS

SELECTION TABLE - EVOPLUS

MODEL	Q=m ³ h	0	4,2	5,4	7,2	9,6	12	14,4	18	24	30	36	42	54	72	
	Q=l/min	0	70	90	120	160	200	240	300	400	500	600	700	900	1200	
EVOPLUS B 120/220.32 M	H (m)	12,1	11,5	10,7	9,5	7,9	6,3	4,7	2,2							
EVOPLUS B 40/220.40 M		4	3,6	3,1	2,5	1,7										
EVOPLUS B 60/220.40 M		6		5,9	5,1	4,1	3	2								
EVOPLUS B 80/220.40 M		8		7,9	7,4	6,1	5	3,7	2							
EVOPLUS B 100/220.40 M		10			9,7	8,3	7	5,5	3,5							
EVOPLUS B 120/250.40 M		12			11,5	10,1	8,7	7,3	5,2							
EVOPLUS B 150/250.40 M		15			14,5	12,8	11,3	9,7	7,5	3,8						
EVOPLUS B 180/250.40 M		18		16,2	14,6	13	11,2	9,6	7,4	3,9						
EVOPLUS B 40/240.50 M		4		3,9	3,6	3,1	2,6	2,1	1,4							
EVOPLUS B 60/240.50 M		6				5,4	4,7	4	3,2	1,6						
EVOPLUS B 80/240.50 M		8			7,4	6,6	5,9	5,2	4,2	2,6						
EVOPLUS B 100/280.50 M		10			9,4	8,4	7,5	6,7	5,5	3,6	2					
EVOPLUS B 120/280.50 M		12			11	9,9	9	8,2	6,9	4,8	3					
EVOPLUS B 150/280.50 M		15,3			12,4	11,5	10,6	9,6	8,3	6,2	4,2					
EVOPLUS B 180/280.50 M		17,1			14	13	12	11,1	9,7	7,4	5,2	3,1				
EVOPLUS B 40/340.65 M		4			4	3,8	3,4	3	2,4	1,4						
EVOPLUS B 60/340.65 M		6				6	5,9	5,4	4,7	3,7	2,2					
EVOPLUS B 80/340.65 M		8				7,8	7,4	6,8	5,9	4,6	3,5	2				
EVOPLUS B 100/340.65 M		10,1				9,8	9,1	8,4	7,6	6,1	4,7	3,1				
EVOPLUS B 120/340.65 M		12				11,5	10,8	10	9	7,4	5,9	4,6	2,8			
EVOPLUS B 150/340.65 M		15,2					14,9	14,7	14	12,1	10,3	8,5	6,9			
EVOPLUS B 40/360.80 M		4							4	3,1	2,2	1,4				
EVOPLUS B 60/360.80 M		6							6	5,2	4	3	2			
EVOPLUS B 80/360.80 M		8							8	6,7	5,4	4,2	3,2			
EVOPLUS B 100/360.80 M		10								9,7	8,3	6,7	5,4	3		
EVOPLUS B 120/360.80 M		12,1								11,6	9,9	8,3	6,8	4,1		
EVOPLUS B 40/450.100 M		4									3,9	3	2			
EVOPLUS B 60/450.100 M		6									5,7	4,7	3,6	1,3		
EVOPLUS B 80/450.100 M		8									8	7,2	5,7	3,4		
EVOPLUS B 100/450.100 M		10,1									10,1	9,2	7,6	4,9	0,7	
EVOPLUS B 120/450.100 M		12,2									11,8	10,4	8,7	5,9	1,5	

EVOPLUS / EVOPLUS SAN

WET ROTOR ELECTRONIC CIRCULATORS

SELECTION TABLE - EVOPLUS

MODEL	Q=m ³ h	0	4,2	5,4	7,2	9,6	12	14,4	18	24	30	36	42	54	72	
	Q=l/min	0	70	90	120	160	200	240	300	400	500	600	700	900	1200	
EVOPLUS D 120/220.32 M	H (m)	12,1	11,5	10,7	9,5	7,9	6,3	4,7	2,2							
EVOPLUS D 40/220.40 M		4	3,6	3,1	2,5	1,7										
EVOPLUS D 60/220.40 M		6		5,9	5,1	4,1	3	2								
EVOPLUS D 80/220.40 M		8		7,9	7,4	6,1	5	3,7	2							
EVOPLUS D 100/220.40 M		10			9,7	8,3	7	5,5	3,5							
EVOPLUS D 120/250.40 M		12			11,5	10,1	8,7	7,3	5,2							
EVOPLUS D 150/250.40 M		15			14,5	12,8	11,3	9,7	7,5	3,8						
EVOPLUS D 180/250.40 M		18		16,2	14,6	13	11,2	9,6	7,4	3,9						
EVOPLUS D 40/240.50 M		4		3,9	3,6	3,1	2,6	2,1	1,4							
EVOPLUS D 60/240.50 M		6				5,4	4,7	4	3,2	1,6						
EVOPLUS D 80/240.50 M		8			7,4	6,6	5,9	5,2	4,2	2,6						
EVOPLUS D 100/280.50 M		10			9,4	8,4	7,5	6,7	5,5	3,6	2					
EVOPLUS D 120/280.50 M		12			11	9,9	9	8,2	6,9	4,8	3					
EVOPLUS D 150/280.50 M		15,3			12,4	11,5	10,6	9,6	8,3	6,2	4,2					
EVOPLUS D 180/280.50 M		17,1			14	13	12	11,1	9,7	7,4	5,2	3,1				
EVOPLUS D 40/340.65 M		4			4	3,8	3,4	3	2,4	1,4						
EVOPLUS D 60/340.65 M		6				6	5,9	5,4	4,7	3,7	2,2					
EVOPLUS D 80/340.65 M		8				7,8	7,4	6,8	5,9	4,6	3,5	2				
EVOPLUS D 100/340.65 M		10,1				9,8	9,1	8,4	7,6	6,1	4,7	3,1				
EVOPLUS D 120/340.65 M		12				11,5	10,8	10	9	7,4	5,9	4,6	2,8			
EVOPLUS D 150/340.65 M		15,2					14,9	14,7	14	12,1	10,3	8,5	6,9			
EVOPLUS D 40/360.80 M		4							4	3,1	2,2	1,4				
EVOPLUS D 60/360.80 M		6							6	5,2	4	3	2			
EVOPLUS D 80/360.80 M		8							8	6,7	5,4	4,2	3,2			
EVOPLUS D 100/360.80 M		10								9,7	8,3	6,7	5,4	3		
EVOPLUS D 120/360.80 M		12,1								11,6	9,9	8,3	6,8	4,1		
EVOPLUS D 40/450.100 M		4									3,9	3	2			
EVOPLUS D 60/450.100 M		6									5,7	4,7	3,6	1,3		
EVOPLUS D 80/450.100 M		8									8	7,2	5,7	3,4		
EVOPLUS D 100/450.100 M		10,1									10,1	9,2	7,6	4,9	0,7	
EVOPLUS D 120/450.100 M		12,2									11,8	10,4	8,7	5,9	1,5	

EVOPLUS / EVOPLUS SAN

WET ROTOR ELECTRONIC CIRCULATORS

SELECTION TABLE - EVOPLUS SAN

MODEL	Q=m ³ h	0	4,2	5,4	7,2	9,6	12	14,4	18	24	30	36	42	54	72
	Q=l/min	0	70	90	120	160	200	240	300	400	500	600	700	900	1200
EVOPLUS B 120/220.32 SAN M		12,1	11,5	10,7	9,5	7,9	6,3	4,7	2,2						
EVOPLUS B 120/250.40 SAN M		12			11,5	10,1	8,7	7,3	5,2						
EVOPLUS B 150/250.40 SAN M		15			14,5	12,8	11,3	9,7	7,5	3,8					
EVOPLUS B 180/250.40 SAN M		18		16,2	14,6	13	11,2	9,6	7,4	3,9					
EVOPLUS B 100/280.50 SAN M		10			9,4	8,4	7,5	6,7	5,5	3,6	2				
EVOPLUS B 120/280.50 SAN M		12			11	9,9	9	8,2	6,9	4,8	3				
EVOPLUS B 150/280.50 SAN M		15,3			12,4	11,5	10,6	9,6	8,3	6,2	4,2				
EVOPLUS B 180/280.50 SAN M		17,1			14	13	12	11,1	9,7	7,4	5,2	3,1			
EVOPLUS B 40/340.65 SAN M		4			4	3,8	3,4	3	2,4	1,4					
EVOPLUS B 60/340.65 SAN M		6				6	5,9	5,4	4,7	3,7	2,2				
EVOPLUS B 80/340.65 SAN M		8				7,8	7,4	6,8	5,9	4,6	3,5	2			
EVOPLUS B 100/340.65 SAN M		10,1				9,8	9,1	8,4	7,6	6,1	4,7	3,1			
EVOPLUS B 120/340.65 SAN M		12				11,5	10,8	10	9	7,4	5,9	4,6	2,8		
EVOPLUS B 150/340.65 SAN M		15,2					14,9	14,7	14	12,1	10,3	8,5	6,9		

EVOPLUS - WET ROTOR ELECTRONIC CIRCULATORS

Pumped liquid temperature range: from -10 °C to +110 °C - Maximum operating pressure: 16 bar (1600 kPa)

EVOPLUS B 120/220.32 M

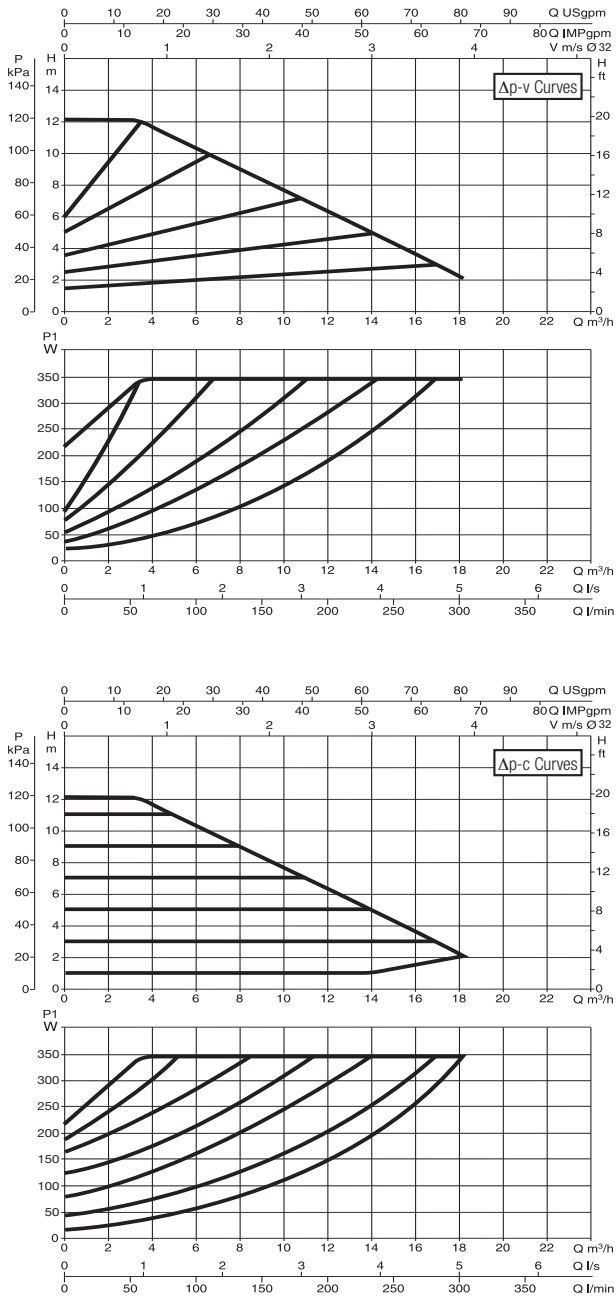

The curves are based on kinematic viscosity values = 1 mm²/s and density equal to 1000 kg/m³. Curve tolerance according to ISO 9906. Fixed speed curves available on the DNA.

MODEL	CENTRE DISTANCE mm	COUNTERFLANGES ON REQUEST	POWER INPUT 50/60 Hz	P1 MAX W	In A	EEI*	MINIMUM SUCTION PRESSURE			WEIGHT Kg
							t°	90°	100°	
EVOPLUS B 120/220.32 M	220	DN32 PN 6	220/240 V	340	1,7	EEI ≤ 0,22	m.c.w.	20	25	24

The parameter of reference for the more efficient circulators is EEI ≤ 0,20.

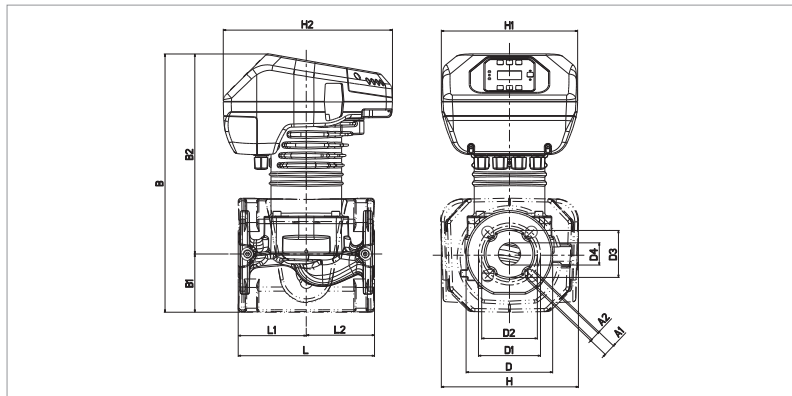

L	L1	L2	A1	A2	B	B1	B2
220	110	110	19	14	417	94	323

D	D1	D2	D3	D4	H	H1	H2
140	100	90	76	36	222	220	273

EVOPLUS - WET ROTOR ELECTRONIC CIRCULATORS

Pumped liquid temperature range: from -10 °C to +110 °C - Maximum operating pressure: 16 bar (1600 kPa)

EVOPLUS B 40/220.40 M

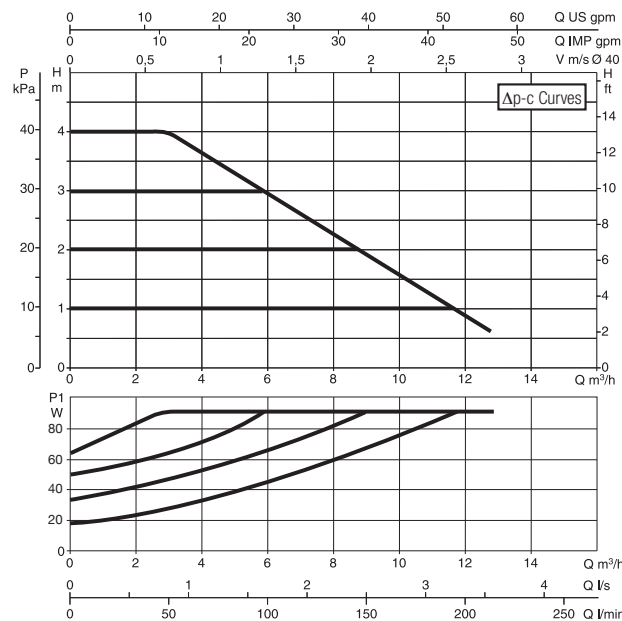
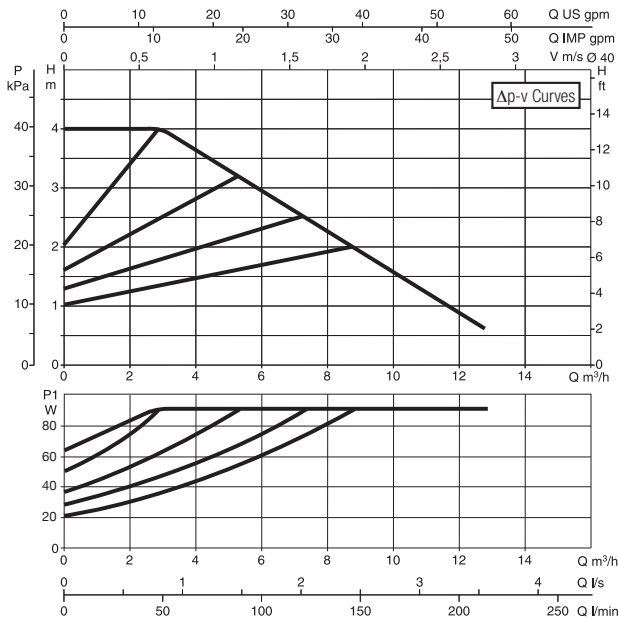

EVOPLUS B 60/220.40 M

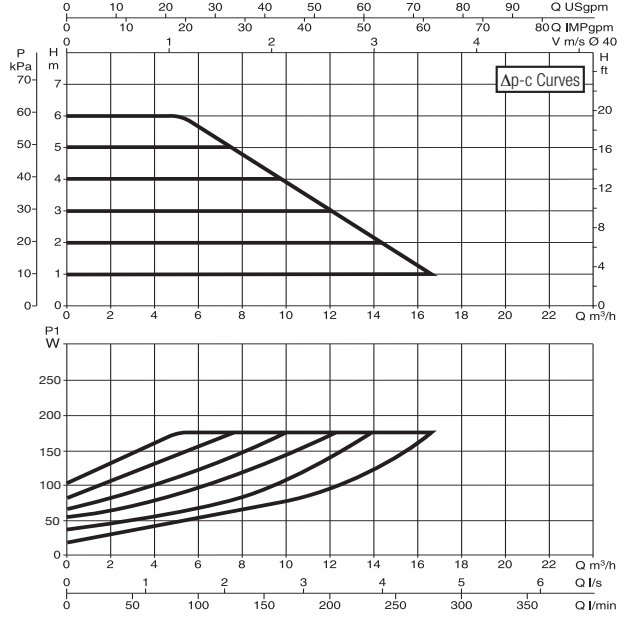
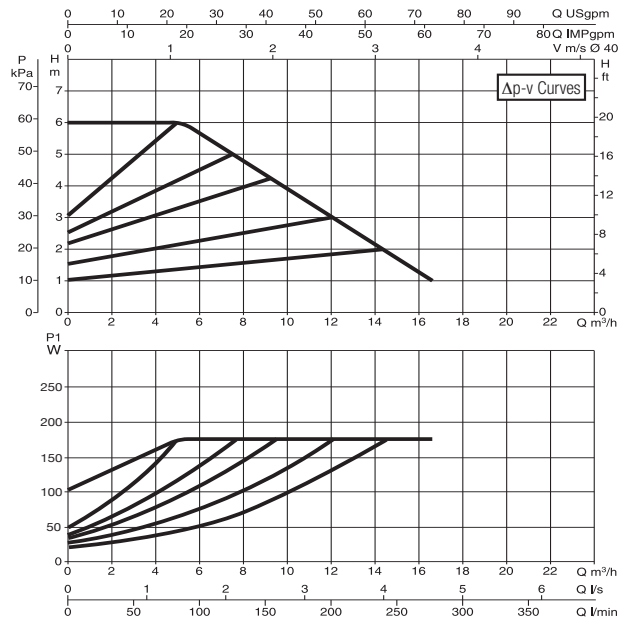

The curves are based on kinematic viscosity values = 1 mm²/s and density equal to 1000 kg/m³. Curve tolerance according to ISO 9906. Fixed speed curves available on the DNA.

MODEL	CENTRE DISTANCE mm	COUNTERFLANGES ON REQUEST	POWER INPUT 50/60 Hz	P1 MAX W	In A	EEI *	MINIMUM SUCTION PRESSURE			WEIGHT Kg
							t°	90°	100°	
EVOPLUS B 40/220.40 M	220	DN40 PN 10	220/240 V	90	0,7	EEI ≤ 0,23	m.c.w.	20	25	20,8
EVOPLUS B 60/220.40 M	220	DN40 PN 10	220/240 V	175	1	EEI ≤ 0,23	m.c.w.	20	25	20,8

The parameter of reference for the more efficient circulators is EEI ≤ 0,20.

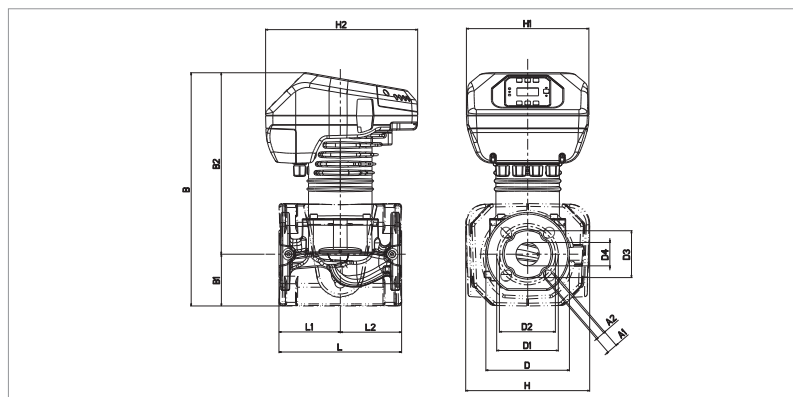

L	L1	L2	A1	A2	B	B1	B2
220	110	110	19	14	419	93	326

D	D1	D2	D3	D4	H	H1	H2
150	110	100	84	42	222	220	273

EVOPLUS - WET ROTOR ELECTRONIC CIRCULATORS

Pumped liquid temperature range: from -10 °C to +110 °C - Maximum operating pressure: 16 bar (1600 kPa)

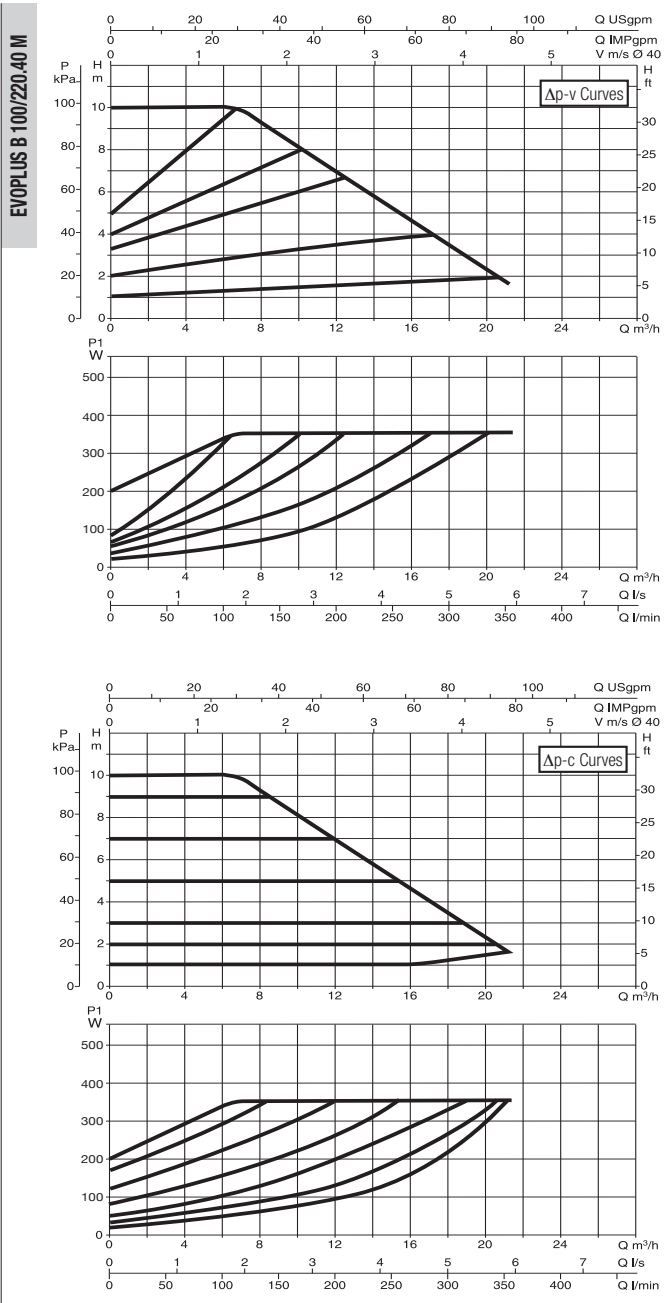
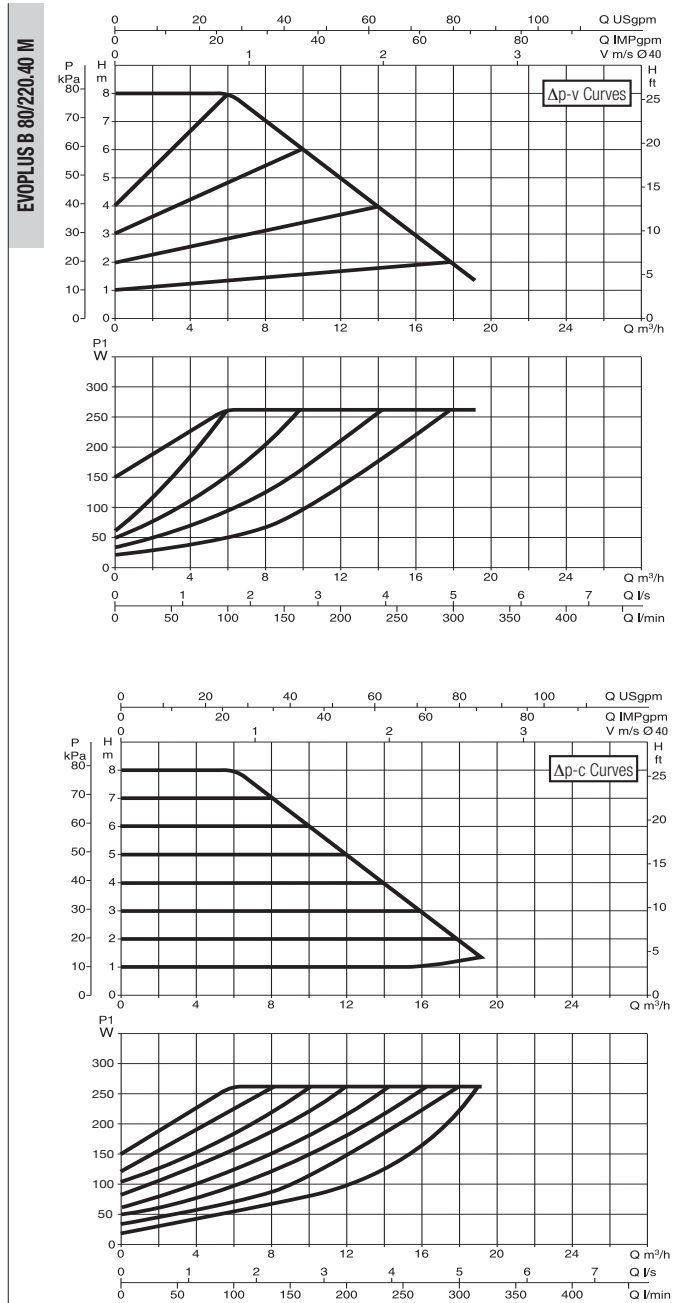

The curves are based on kinematic viscosity values = 1 mm²/s and density equal to 1000 kg/m³. Curve tolerance according to ISO 9906. Fixed speed curves available on the DNA.

MODEL	CENTRE DISTANCE mm	COUNTERFLANGES ON REQUEST	POWER INPUT 50/60 Hz	P1 MAX W	In A	EEI*	MINIMUM SUCTION PRESSURE			WEIGHT Kg
							t°	90°	100°	
EVOPLUS B 80/220.40 M	220	DN40 PN 10	220/240 V	260	1,35	EEI ≤ 0,21	m.c.w.	20	25	20,8
EVOPLUS B 100/220.40 M	220	DN40 PN 10	220/240 V	350	1,75	EEI ≤ 0,20	m.c.w.	20	25	20,8

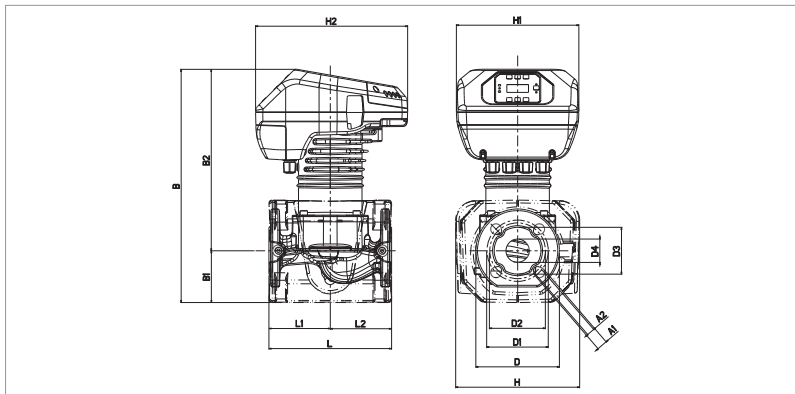

The parameter of reference for the more efficient circulators is EEI ≤ 0,20.

L	L1	L2	A1	A2	B	B1	B2
220	110	110	19	14	419	93	326

D	D1	D2	D3	D4	H	H1	H2
150	110	100	84	42	222	220	273



EVOPLUS - WET ROTOR ELECTRONIC CIRCULATORS

Pumped liquid temperature range: from -10 °C to +110 °C - Maximum operating pressure: 16 bar (1600 kPa)

EVOPLUS B 120/250.40 M

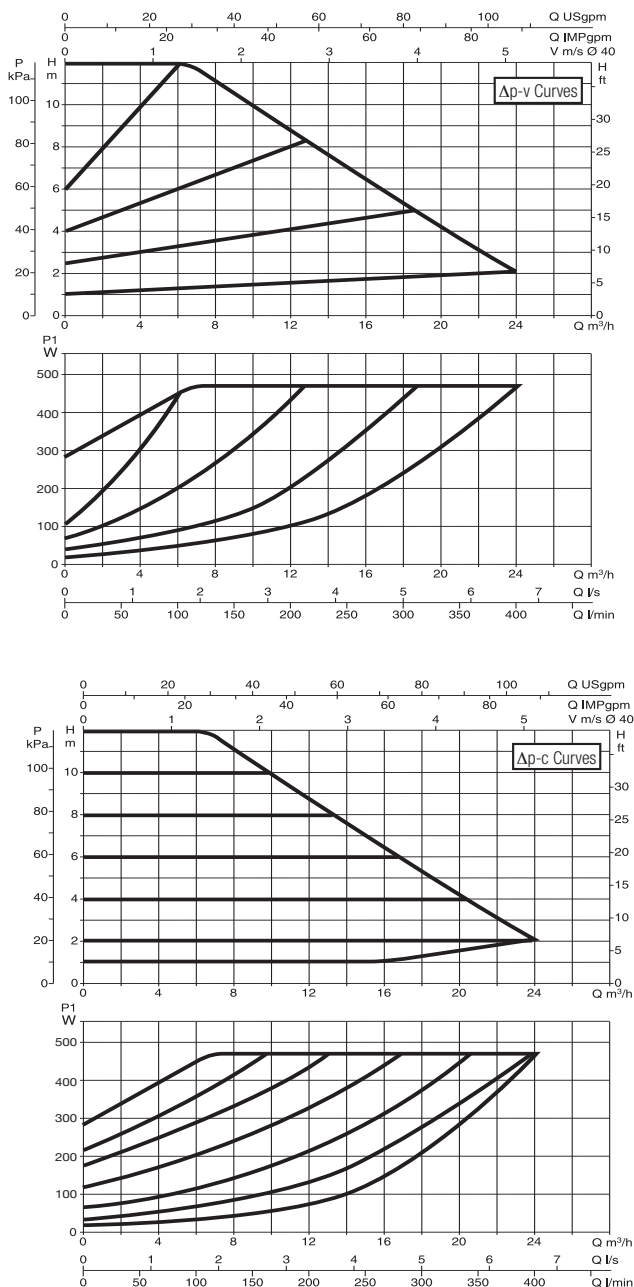

EVOPLUS B 150/250.40 M

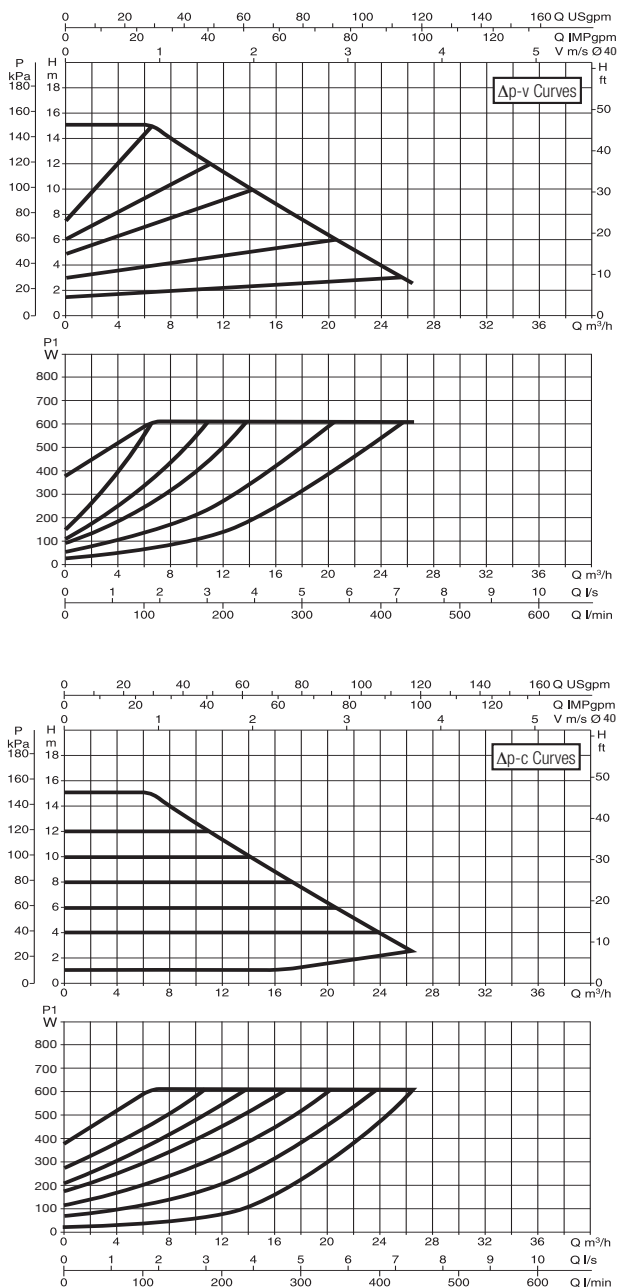

The curves are based on kinematic viscosity values = 1 mm²/s and density equal to 1000 kg/m³. Curve tolerance according to ISO 9906. Fixed speed curves available on the DNA.

MODEL	CENTRE DISTANCE mm	COUNTERFLANGES ON REQUEST	POWER INPUT 50/60 Hz	P1 MAX W	In A	EEI*	MINIMUM SUCTION PRESSURE			WEIGHT Kg
							t°	90°	100°	
EVOPLUS B 120/250.40 M	250	DN40 PN 10	220/240 V	465	2,2	EEI ≤ 0,20	m.c.w.	20	25	20
EVOPLUS B 150/250.40 M	250	DN40 PN 10	220/240 V	610	2,9	EEI ≤ 0,20	m.c.w.	20	25	20

The parameter of reference for the more efficient circulators is EEI ≤ 0,20.

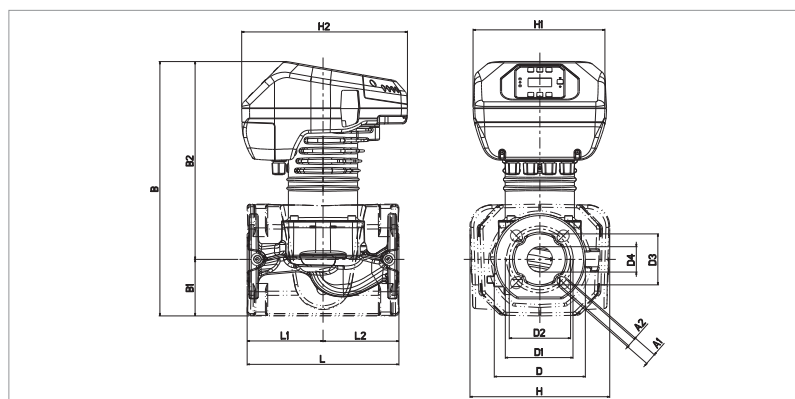

L	L1	L2	A1	A2	B	B1	B2
250	125	125	19	14	419	93	326

D	D1	D2	D3	D4	H	H1	H2
150	110	100	84	42	230	220	273

EVOPLUS - WET ROTOR ELECTRONIC CIRCULATORS

Pumped liquid temperature range: from -10 °C to +110 °C - Maximum operating pressure: 16 bar (1600 kPa)

EVOPLUS B 180/250.40 M

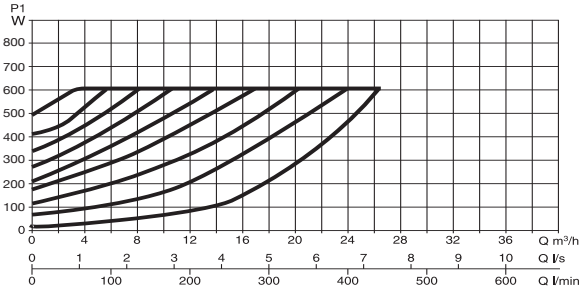
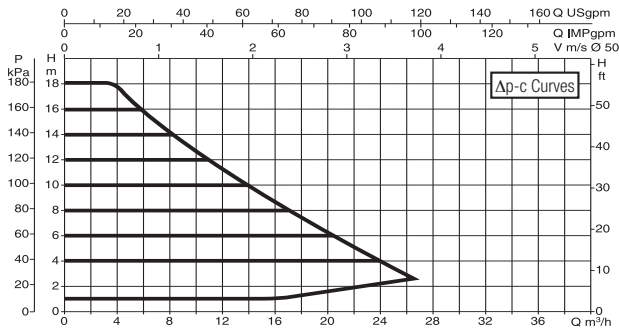
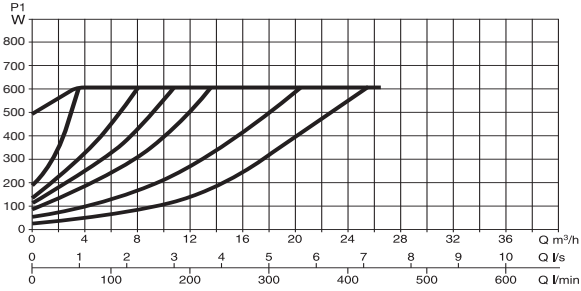
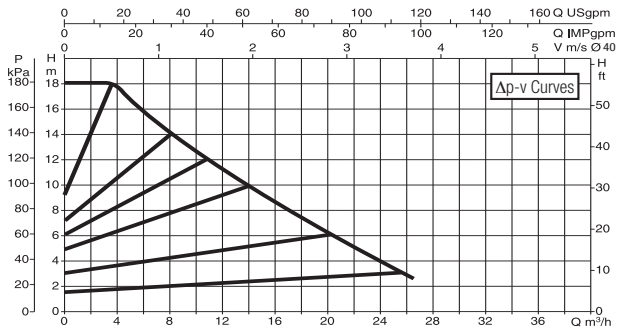

The curves are based on kinematic viscosity values = 1 mm²/s and density equal to 1000 kg/m³. Curve tolerance according to ISO 9906. Fixed speed curves available on the DNA.

MODEL	CENTRE DISTANCE mm	COUNTERFLANGES ON REQUEST	POWER INPUT 50/60 Hz	P1 MAX W	In A	EEI*	MINIMUM SUCTION PRESSURE			WEIGHT Kg
							t°	90°	100°	
EVOPLUS B 180/250.40 M	250	DN40 PN 10	220/240 V	610	2,9	EEI ≤ 0,20	m.c.w.	20	25	20

The parameter of reference for the more efficient circulators is EEI ≤ 0,20.

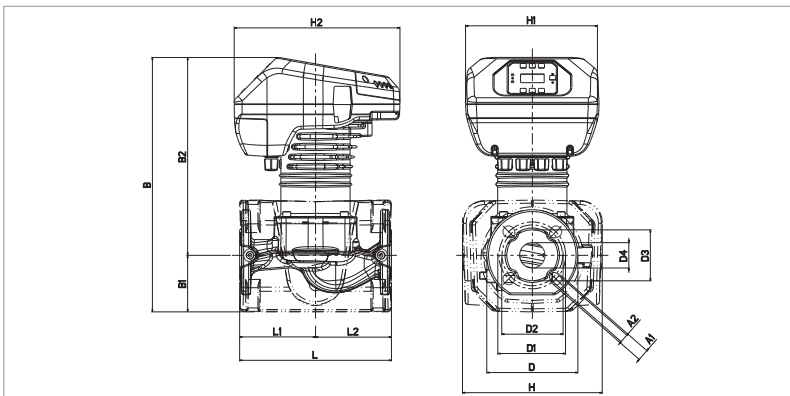

L	L1	L2	A1	A2	B	B1	B2
250	125	125	19	14	419	93	326

D	D1	D2	D3	D4	H	H1	H2
150	110	100	84	42	230	220	273

EVOPLUS - WET ROTOR ELECTRONIC CIRCULATORS

Pumped liquid temperature range: from -10 °C to +110 °C - Maximum operating pressure: 16 bar (1600 kPa)

EVOPLUS B 40/240.50 M

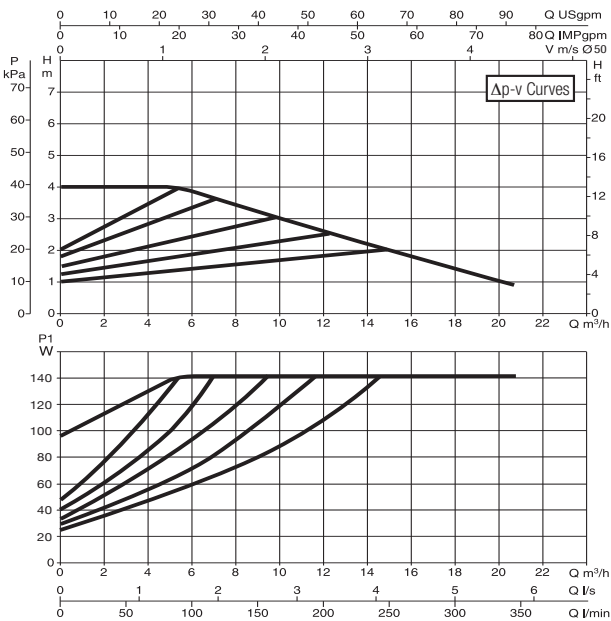

EVOPLUS B 60/240.50 M

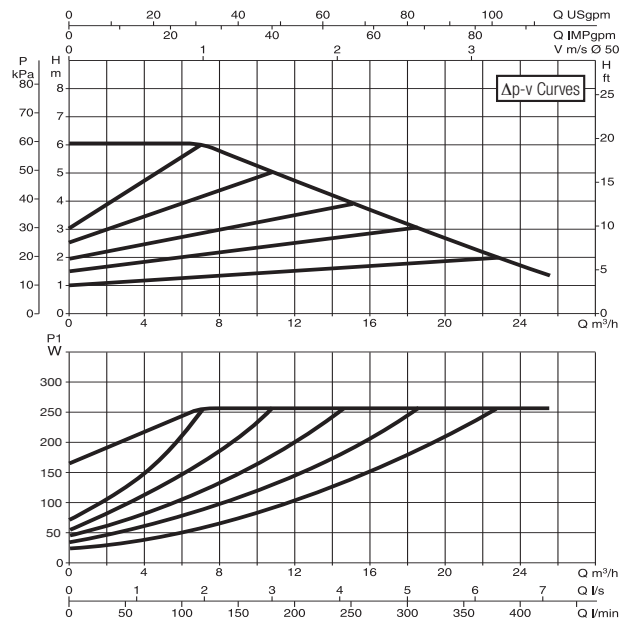

WET ROTOR ELECTRONIC CIRCULATORS

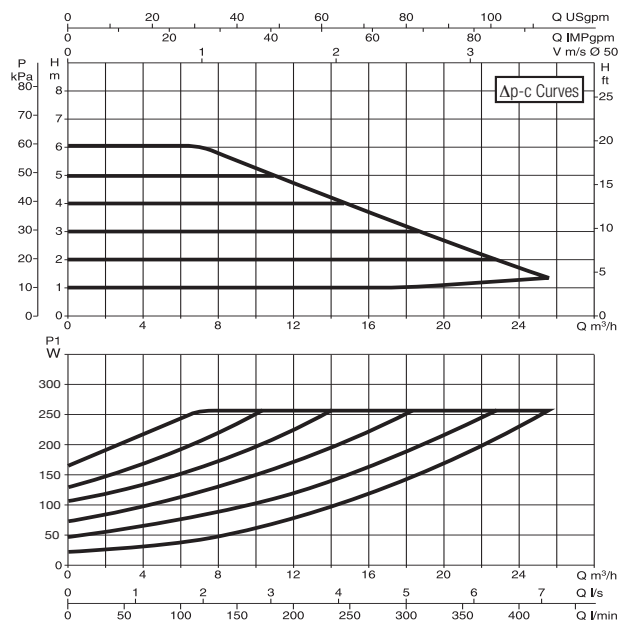
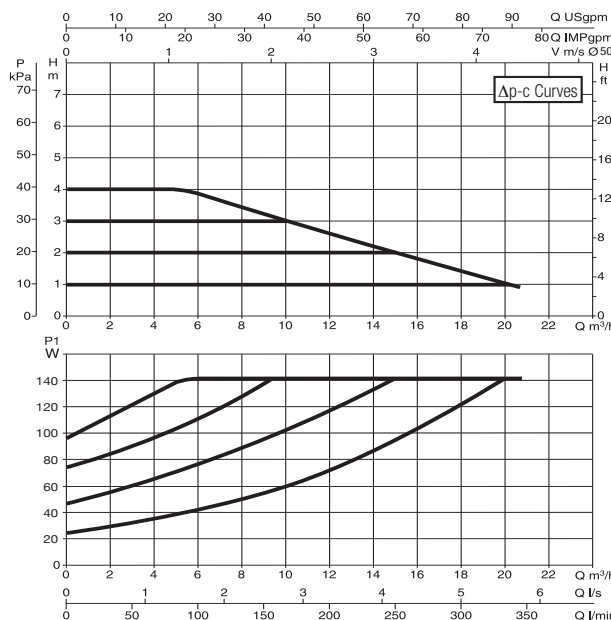

The curves are based on kinematic viscosity values = 1 mm²/s and density equal to 1000 kg/m³. Curve tolerance according to ISO 9906. Fixed speed curves available on the DNA.

MODEL	CENTRE DISTANCE mm	COUNTERFLANGES ON REQUEST	POWER INPUT 50/60 Hz	P1 MAX W	In A	EEI*	MINIMUM SUCTION PRESSURE			WEIGHT Kg
							t°	90°	100°	
EVOPLUS B 40/240.50 M	240	DN50 PN 10	220/240 V	140	0,87	EEI ≤ 0,23	m.c.w.	20	25	21,4
EVOPLUS B 60/240.50 M	240	DN50 PN 10	220/240 V	260	1,35	EEI ≤ 0,21	m.c.w.	20	25	21,4

*The parameter of reference for the more efficient circulators is EEI ≤ 0,20.

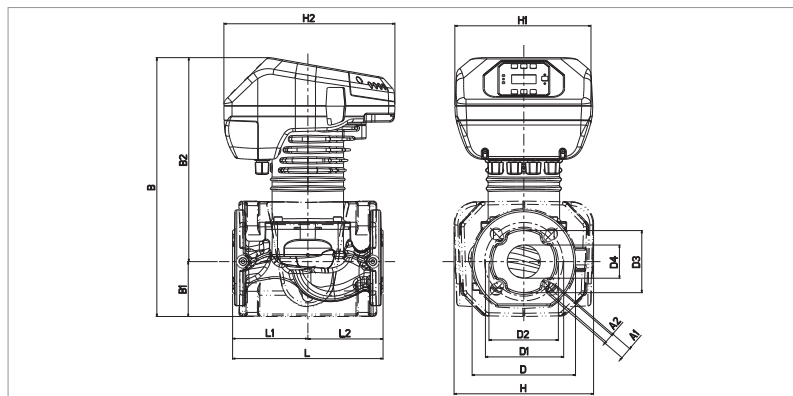

L	L1	L2	A1	A2	B	B1	B2
240	120	120	19	14	413	87	325

D	D1	D2	D3	D4	H	H1	H2
165	125	110	99	53	222	220	273

EVOPLUS - WET ROTOR ELECTRONIC CIRCULATORS

Pumped liquid temperature range: from -10 °C to +110 °C - Maximum operating pressure: 16 bar (1600 kPa)

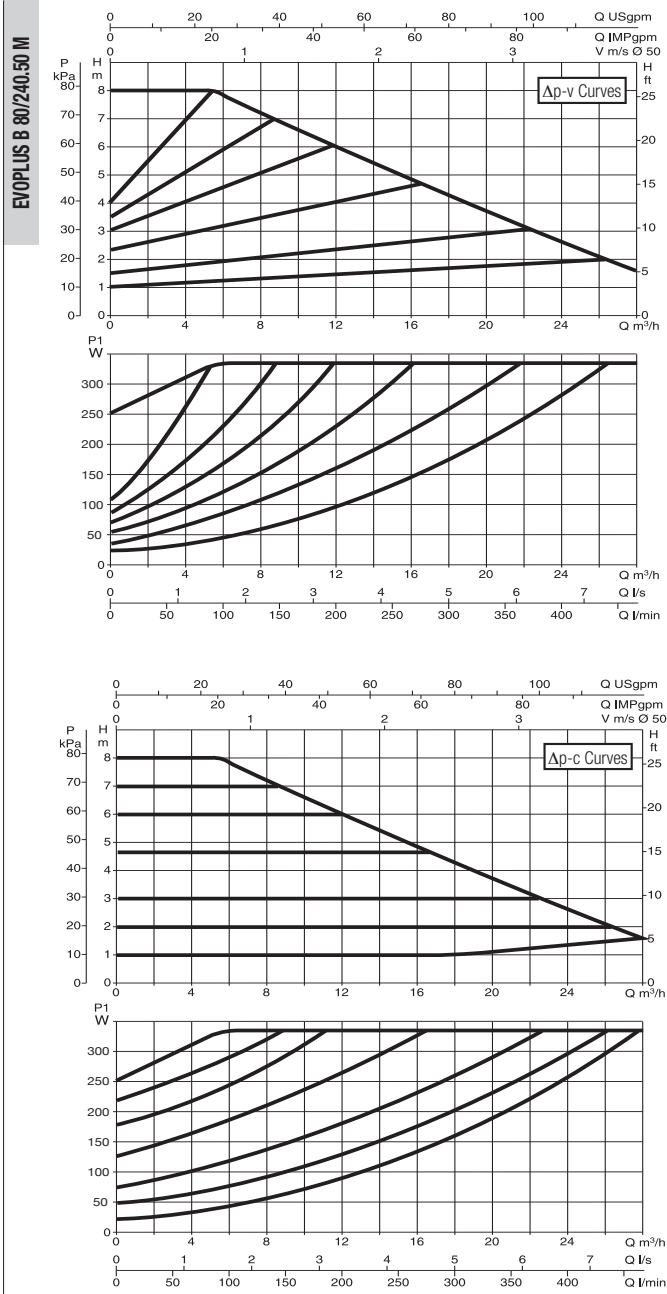

The curves are based on kinematic viscosity values = 1 mm²/s and density equal to 1000 kg/m³. Curve tolerance according to ISO 9906. Fixed speed curves available on the DNA.

MODEL	CENTRE DISTANCE mm	COUNTERFLANGES ON REQUEST	POWER INPUT 50/60 Hz	P1 MAX W	In A	EEI*	MINIMUM SUCTION PRESSURE			WEIGHT Kg
							t°	90°	100°	
EVOPLUS B 80/240.50 M	240	DN50 PN 10	220/240 V	330	0,87	EEI ≤ 0,21	m.c.w.	20	25	21,4

*The parameter of reference for the more efficient circulators is EEI ≤ 0,20.

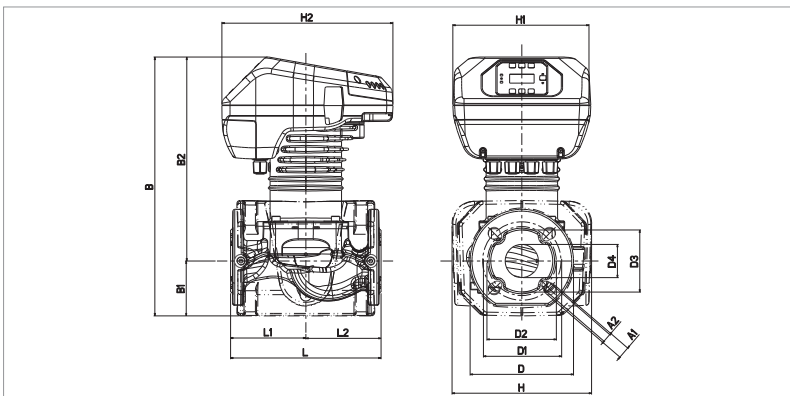

L	L1	L2	A1	A2	B	B1	B2
240	120	120	19	14	413	87	325

D	D1	D2	D3	D4	H	H1	H2
165	125	110	99	53	222	220	273

EVOPLUS - WET ROTOR ELECTRONIC CIRCULATORS

Pumped liquid temperature range: from -10 °C to +110 °C - Maximum operating pressure: 16 bar (1600 kPa)

EVOPLUS B 100/280.50 M

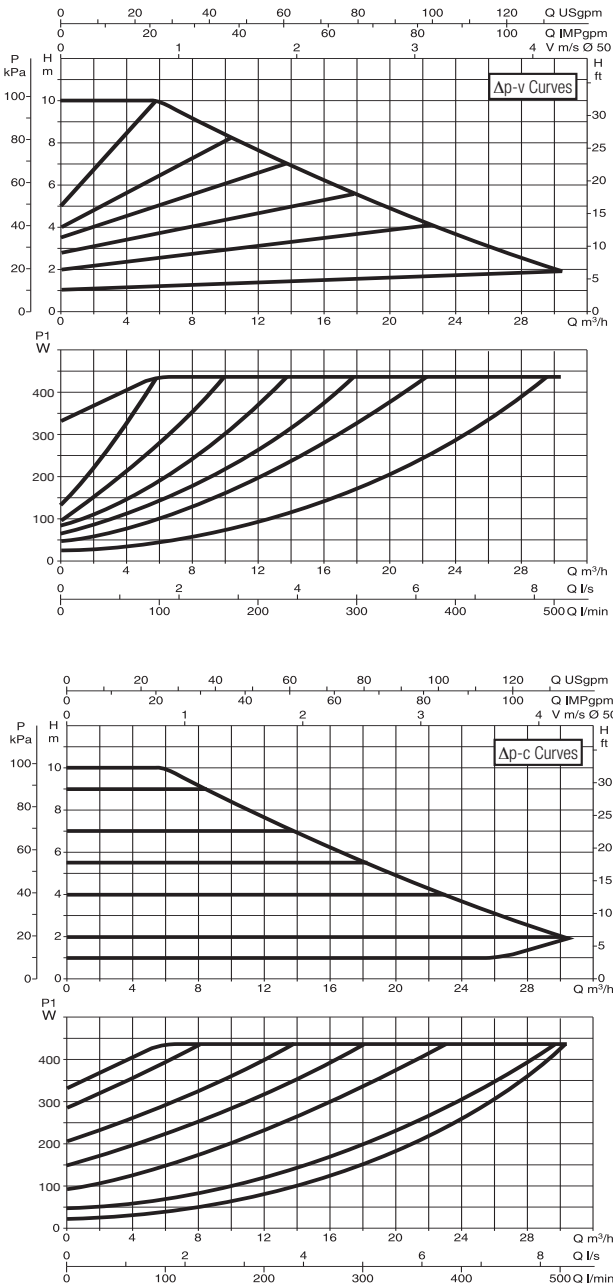

EVOPLUS B 120/280.50 M

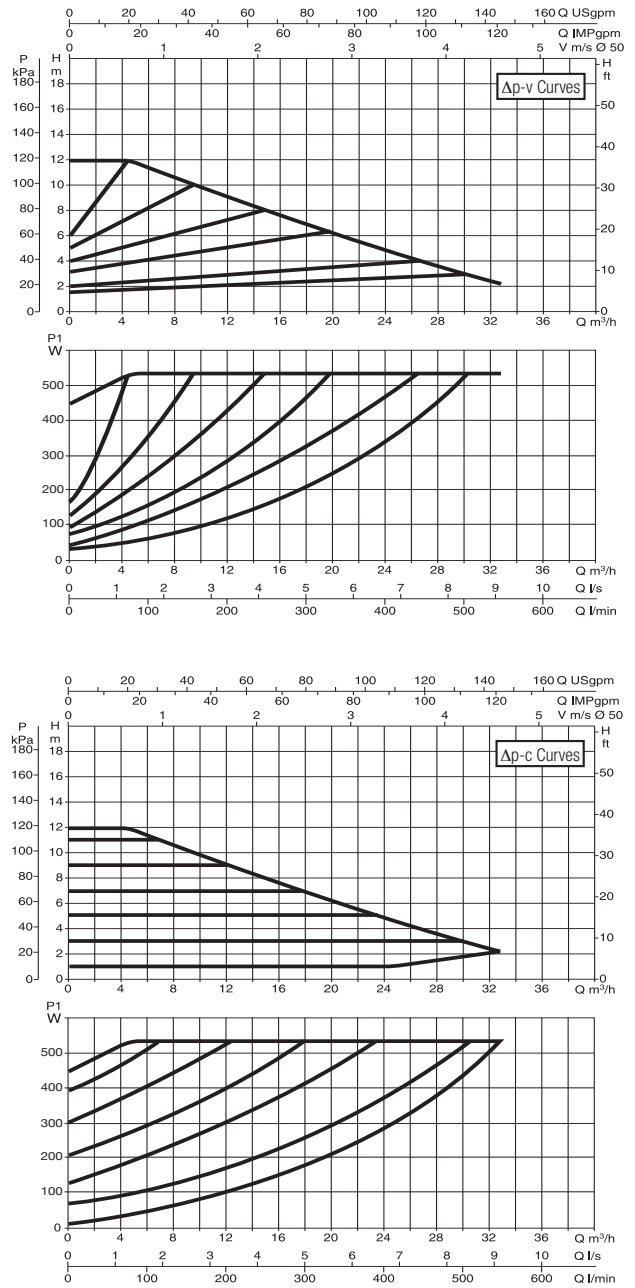

The curves are based on kinematic viscosity values = 1 mm²/s and density equal to 1000 kg/m³. Curve tolerance according to ISO 9906. Fixed speed curves available on the DNA.

MODEL	CENTRE DISTANCE mm	COUNTERFLANGES ON REQUEST	POWER INPUT 50/60 Hz	P1 MAX W	In A	EEI*	MINIMUM SUCTION PRESSURE			WEIGHT Kg
							t°	90°	100°	
EVOPLUS B 100/280.50 M	280	DN50 PN 10	220/240 V	430	2,1	EEI ≤ 0,20	m.c.w.	20	25	22
EVOPLUS B 120/280.50 M	280	DN50 PN 10	220/240 V	530	2,5	EEI ≤ 0,19	m.c.w.	20	25	21,8

* The parameter of reference for the more efficient circulators is EEI ≤ 0,20.

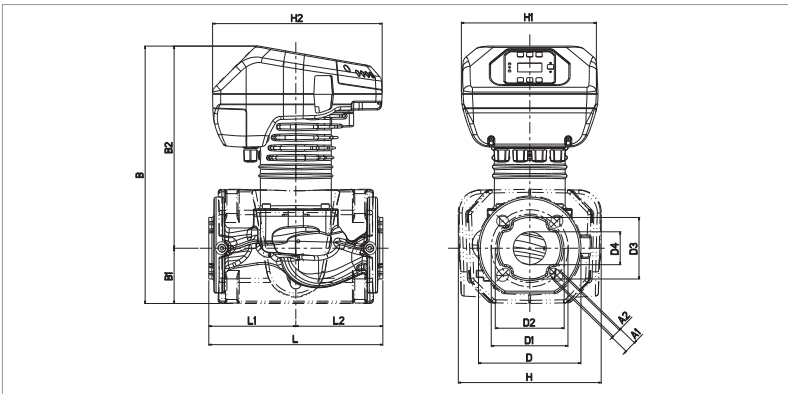

L	L1	L2	A1	A2	B	B1	B2
280	140	140	19	14	413	87	325

D	D1	D2	D3	D4	H	H1	H2
165	125	110	99	53	230	220	273

EVOPLUS - WET ROTOR ELECTRONIC CIRCULATORS

Pumped liquid temperature range: from -10 °C to +110 °C - Maximum operating pressure: 16 bar (1600 kPa)

EVOPLUS B 150/280.50 M

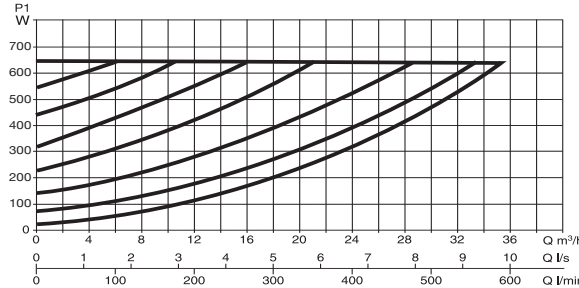
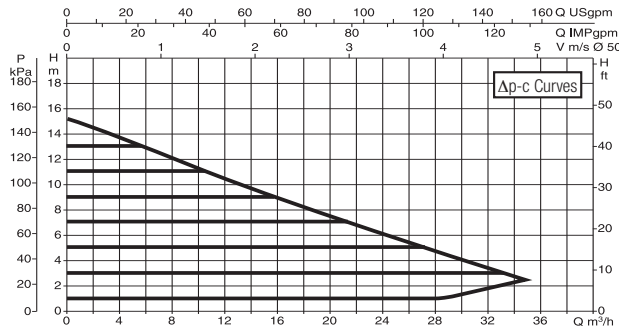
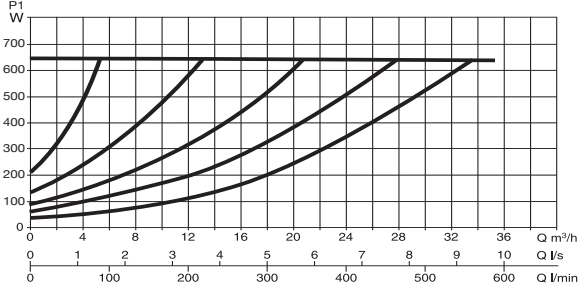
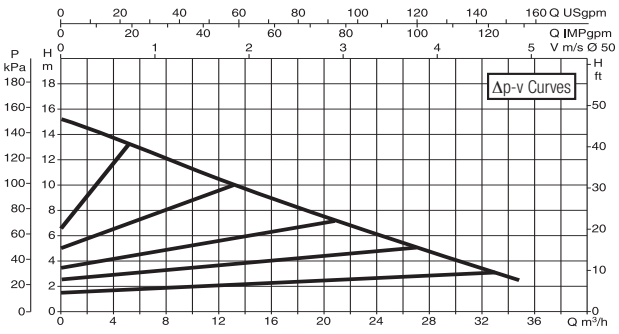

EVOPLUS B 180/280.50 M

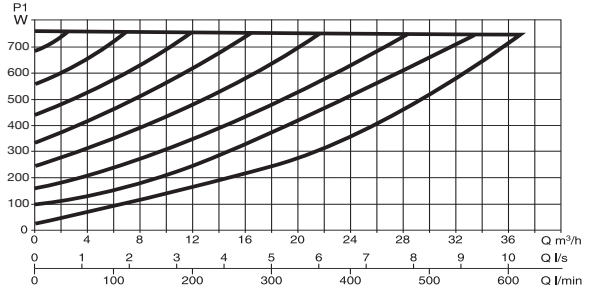
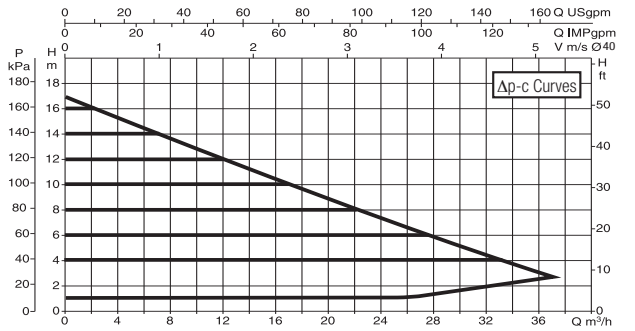
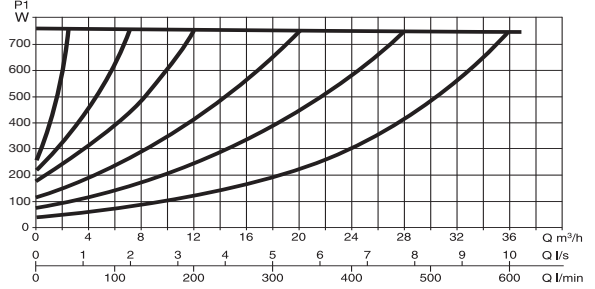
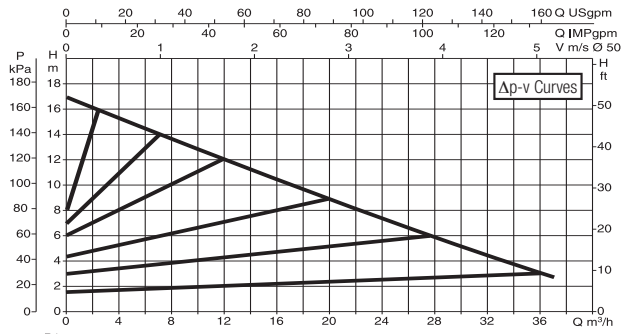

The curves are based on kinematic viscosity values = 1 mm²/s and density equal to 1000 kg/m³. Curve tolerance according to ISO 9906. Fixed speed curves available on the DNA.

MODEL	CENTRE DISTANCE mm	COUNTERFLANGES ON REQUEST	POWER INPUT 50/60 Hz	P1 MAX W	In A	EEI*	MINIMUM SUCTION PRESSURE			WEIGHT Kg
							t°	90°	100°	
EVOPLUS B 150/280.50 M	280	DN50 PN 10	220/240 V	640	3	EEI ≤ 0,19	m.c.w.	20	25	22,8
EVOPLUS B 180/280.50 M	280	DN50 PN 10	220/240 V	750	3,45	EEI ≤ 0,19	m.c.w.	20	25	22,8

* The parameter of reference for the more efficient circulators is EEI ≤ 0,20.

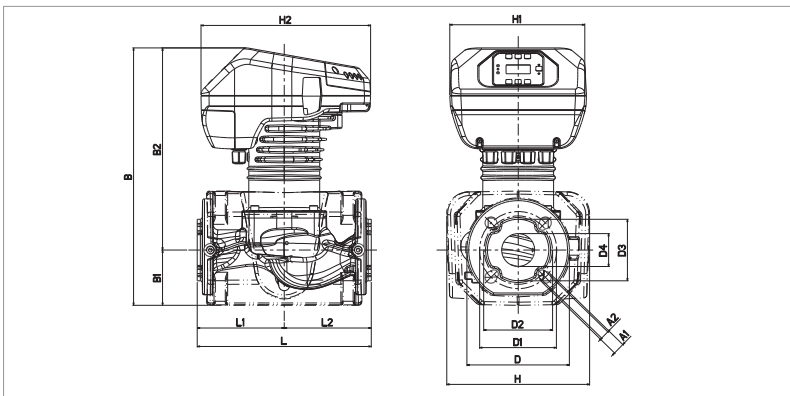

L	L1	L2	A1	A2	B	B1	B2
280	140	140	19	14	413	87	325

D	D1	D2	D3	D4	H	H1	H2
165	125	110	99	53	230	220	273

EVOPLUS - WET ROTOR ELECTRONIC CIRCULATORS

Pumped liquid temperature range: from -10 °C to +110 °C - Maximum operating pressure: 16 bar (1600 kPa)

EVOPLUS B 40/340.65 M

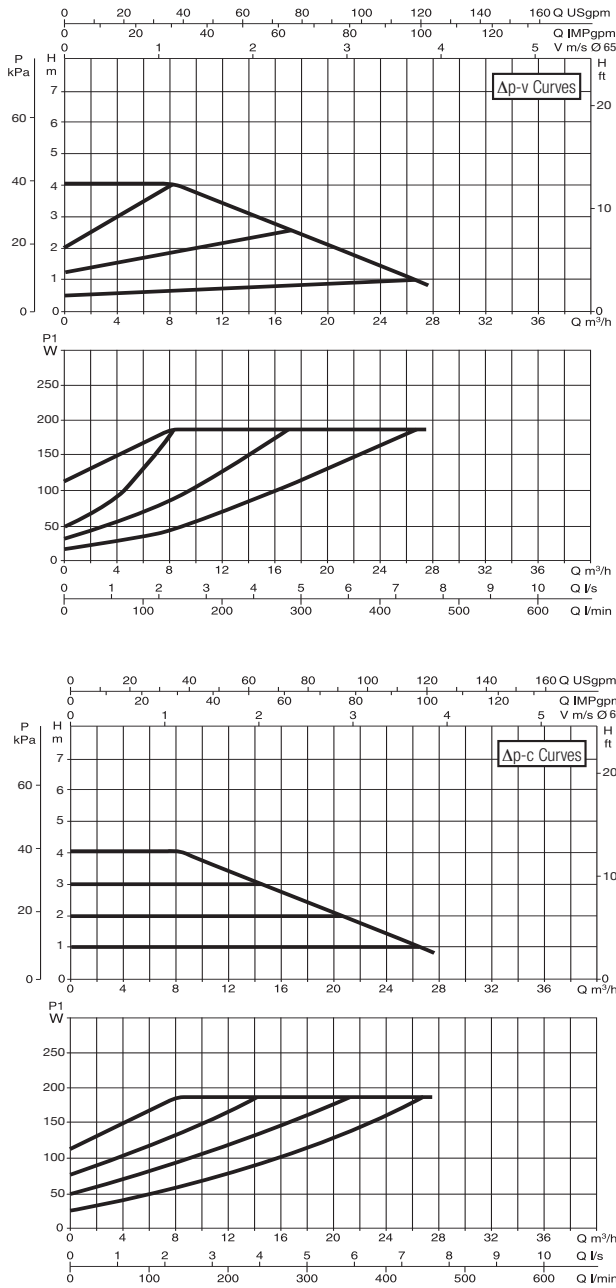

EVOPLUS B 60/340.65 M

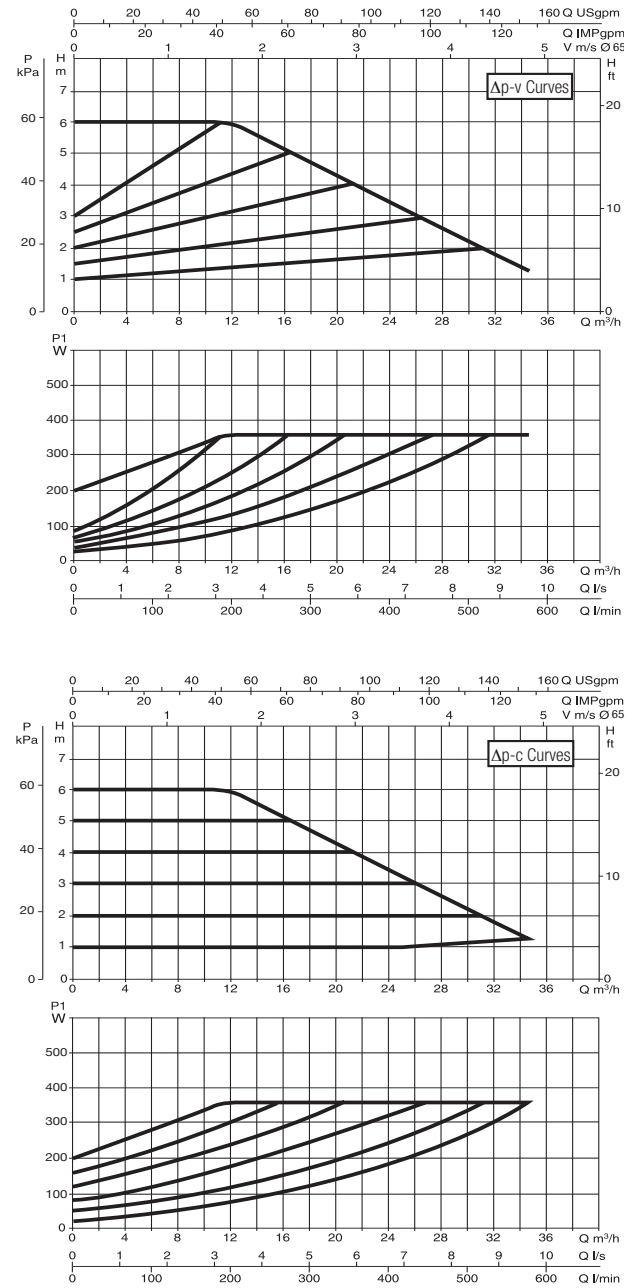

WET ROTOR ELECTRONIC CIRCULATORS

The curves are based on kinematic viscosity values = 1 mm²/s and density equal to 1000 kg/m³. Curve tolerance according to ISO 9906. Fixed speed curves available on the DNA.

MODEL	CENTRE DISTANCE mm	COUNTERFLANGES ON REQUEST	POWER INPUT 50/60 Hz	P1 MAX W	In A	EEI*	MINIMUM SUCTION PRESSURE			WEIGHT Kg
							t°	90°	100°	
EVOPLUS B 40/340.65 M	340	DN65 PN 10	220/240 V	190	1,1	EEI ≤ 0,21	m.c.w.	20	25	23,8
EVOPLUS B 60/340.65 M	340	DN65 PN 10	220/240 V	355	1,8	EEI ≤ 0,20	m.c.w.	20	25	23,8

* The parameter of reference for the more efficient circulators is EEI ≤ 0,20.

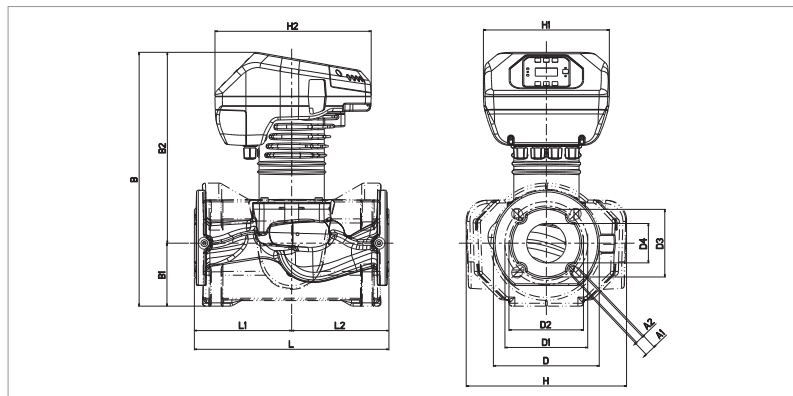

L	L1	L2	A1	A2	B	B1	B2
340	170	170	19	14	443	110	333

D	D1	D2	D3	D4	H	H1	H2
185	145	130	118	69	280	220	273

EVOPLUS - WET ROTOR ELECTRONIC CIRCULATORS

Pumped liquid temperature range: from -10 °C to +110 °C - Maximum operating pressure: 16 bar (1600 kPa)

EVOPLUS B 80/340.65 M

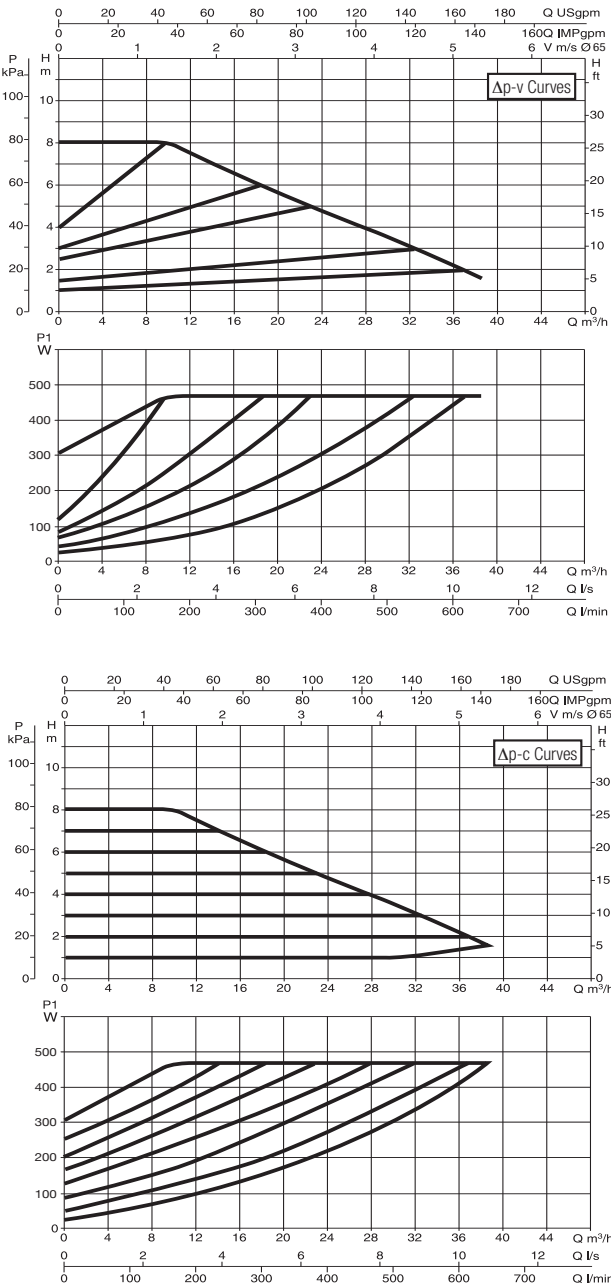

EVOPLUS B 100/340.65 M

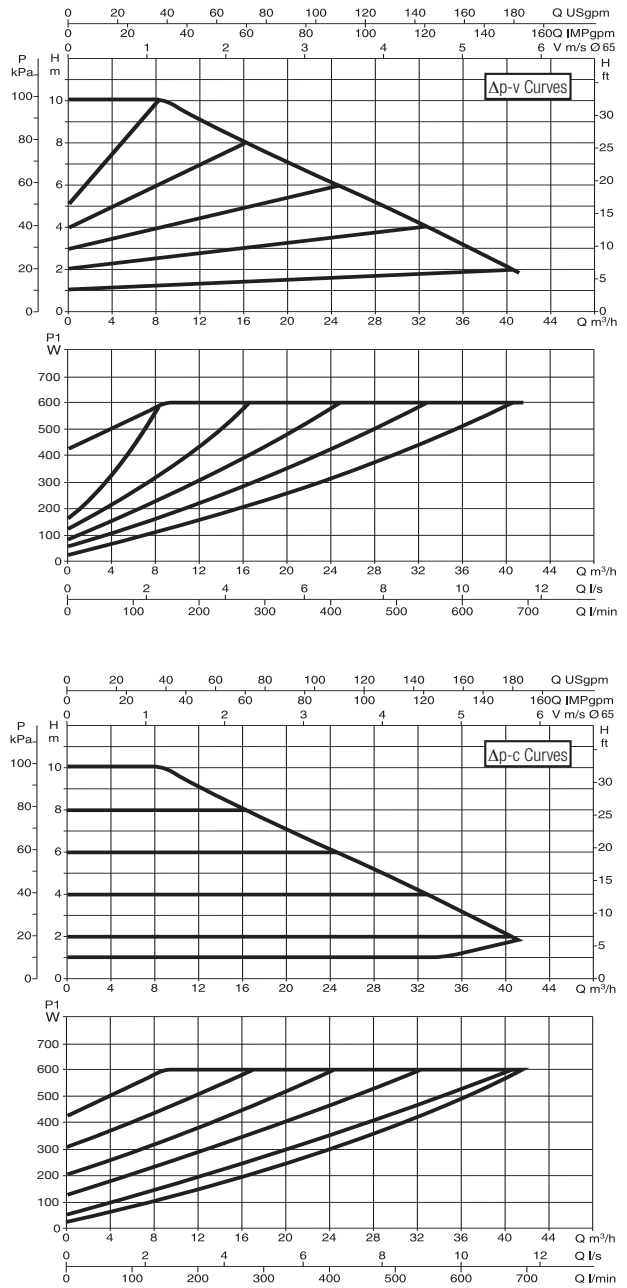

The curves are based on kinematic viscosity values = 1 mm²/s and density equal to 1000 kg/m³. Curve tolerance according to ISO 9906. Fixed speed curves available on the DNA.

MODEL	CENTRE DISTANCE mm	COUNTERFLANGES ON REQUEST	POWER INPUT 50/60 Hz	P1 MAX W	In A	EEI*	MINIMUM SUCTION PRESSURE			WEIGHT Kg
							t°	90°	100°	
EVOPLUS B 80/340.65 M	340	DN65 PN 10	220/240 V	465	2,2	EEI ≤ 0,19	m.c.w.	20	25	24,6
EVOPLUS B 100/340.65 M	340	DN65 PN 10	220/240 V	590	2,8	EEI ≤ 0,18	m.c.w.	20	25	25

* The parameter of reference for the more efficient circulators is EEI ≤ 0,20.

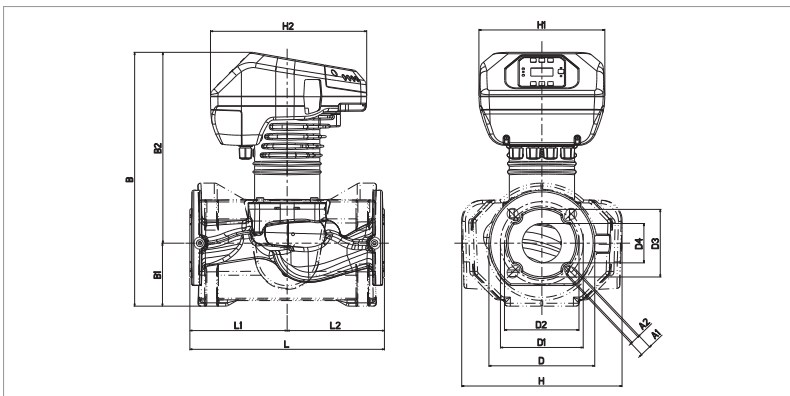

L	L1	L2	A1	A2	B	B1	B2
340	170	170	19	14	443	110	333

D	D1	D2	D3	D4	H	H1	H2
185	145	130	118	69	280	220	273

EVOPLUS - WET ROTOR ELECTRONIC CIRCULATORS

Pumped liquid temperature range: from -10 °C to +110 °C - Maximum operating pressure: 16 bar (1600 kPa)

EVOPLUS B 120/340.65 M

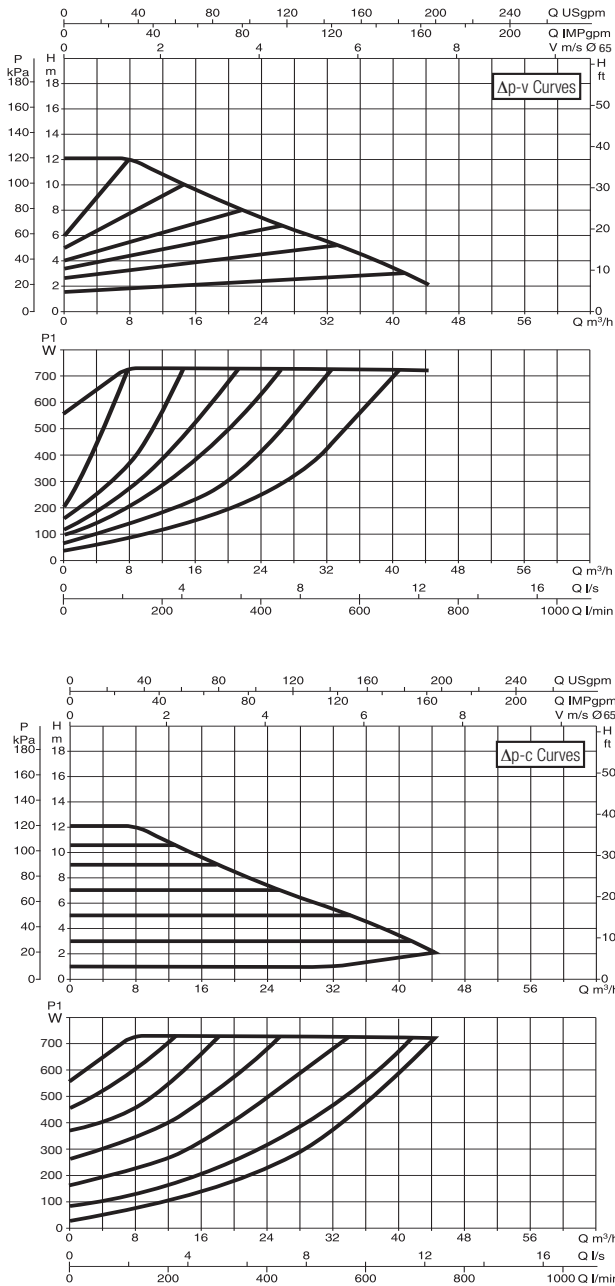

EVOPLUS B 150/340.65 M

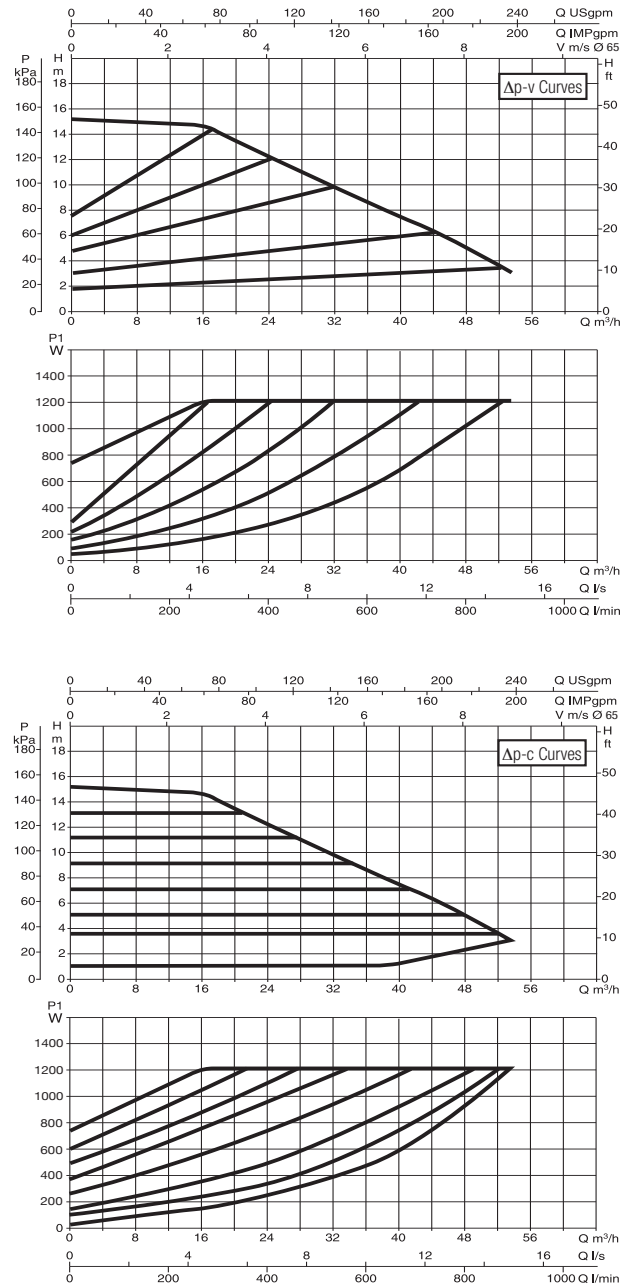

The curves are based on kinematic viscosity values = 1 mm²/s and density equal to 1000 kg/m³. Curve tolerance according to ISO 9906. Fixed speed curves available on the DNA.

MODEL	CENTRE DISTANCE mm	COUNTERFLANGES ON REQUEST	POWER INPUT 50/60 Hz	P1 MAX W	In A	EEI*	MINIMUM SUCTION PRESSURE			WEIGHT Kg
							t°	90°	100°	
EVOPLUS B 120/340.65 M	340	DN65 PN 10	220/240 V	730	3,45	EEI ≤ 0,18	m.c.w.	20	25	24,6
EVOPLUS B 150/340.65 M	340	DN65 PN 10	220/240 V	1210	5,5	EEI ≤ 0,18	m.c.w.	20	25	27

* The parameter of reference for the more efficient circulators is EEI ≤ 0,20.

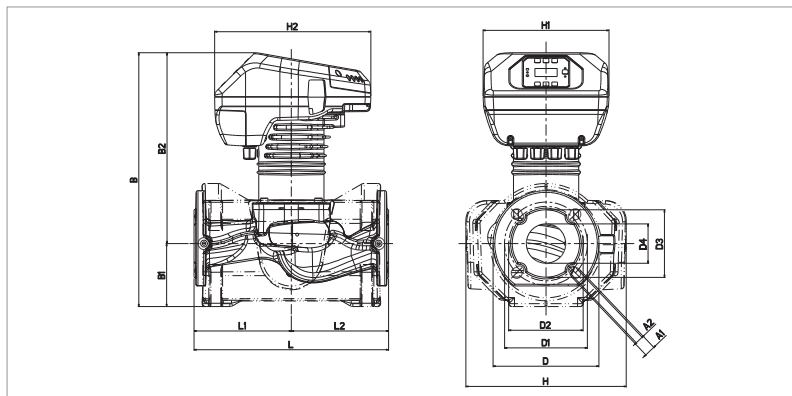

L	L1	L2	A1	A2	B	B1	B2
340	170	170	19	14	443	110	333

D	D1	D2	D3	D4	H	H1	H2
185	145	130	118	69	280	220	273

EVOPLUS - WET ROTOR ELECTRONIC CIRCULATORS

Pumped liquid temperature range: from -10 °C to +110 °C - Maximum operating pressure: 16 bar (1600 kPa)

EVOPLUS B 40/360.80 M

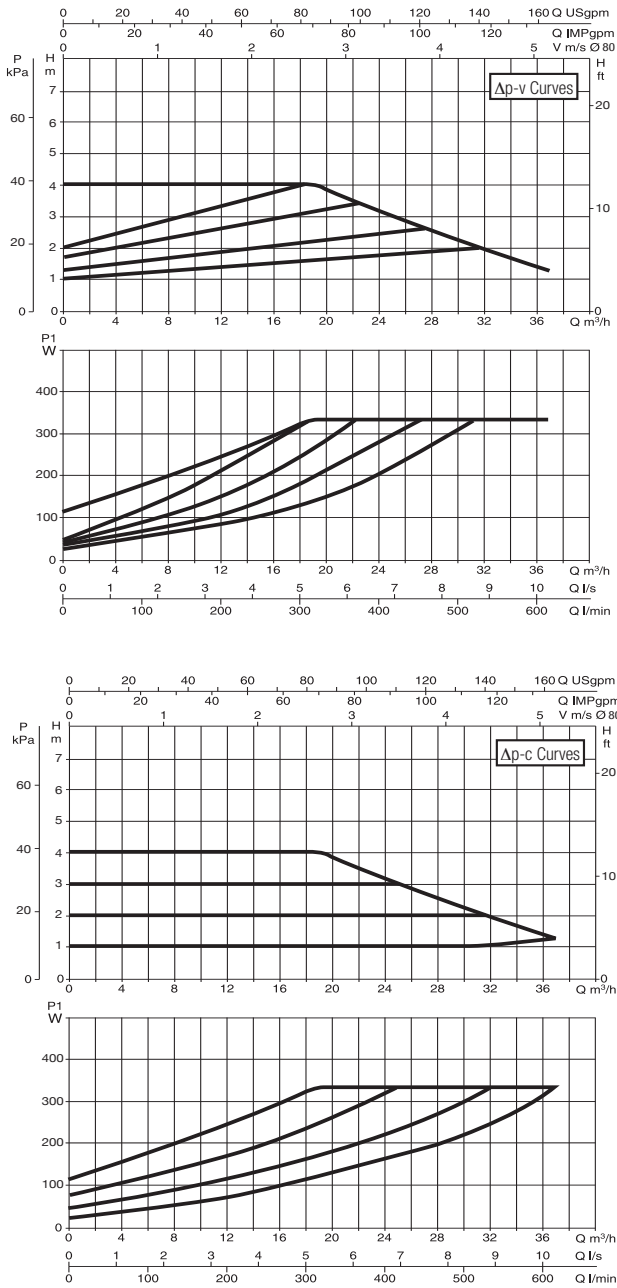

EVOPLUS B 60/360.80 M

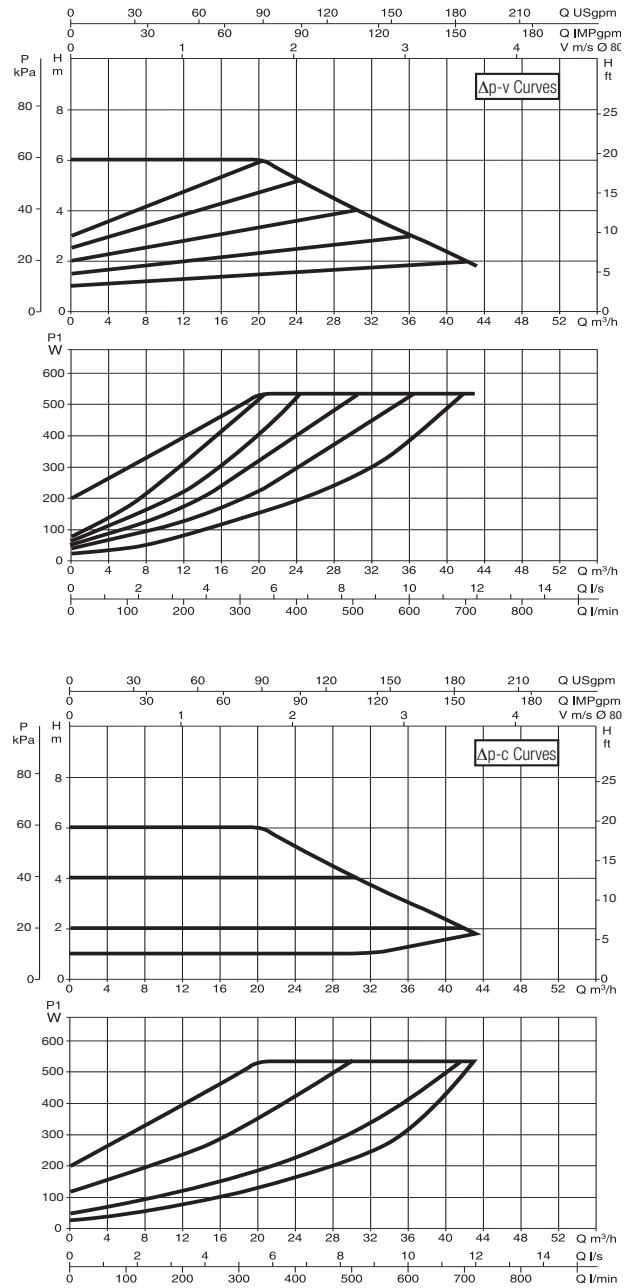

The curves are based on kinematic viscosity values = 1 mm²/s and density equal to 1000 kg/m³. Curve tolerance according to ISO 9906. Fixed speed curves available on the DNA.

MODEL	CENTRE DISTANCE mm	COUNTERFLANGES ON REQUEST	POWER INPUT 50/60 Hz	P1 MAX W	In A	EEI*	MINIMUM SUCTION PRESSURE			WEIGHT Kg
							t°	90°	100°	
EVOPLUS B 40/360.80 M	360	DN80 PN 10	220/240 V	330	1,65	EEI ≤ 0,19	m.c.w.	20	25	30,2
EVOPLUS B 60/360.80 M	360	DN80 PN 10	220/240 V	535	2,5	EEI ≤ 0,20	m.c.w.	20	25	30,2

*The parameter of reference for the more efficient circulators is EEI ≤ 0,20.

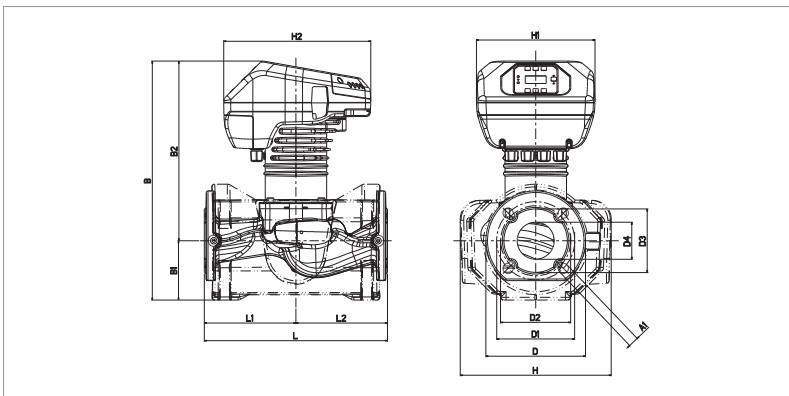

L	L1	L2	A1	B	B1	B2	D
360	180	180	19	446	106	340	200

D1	D3	D4	H	H1	H2
160	132	80	279	220	273

EVOPLUS - WET ROTOR ELECTRONIC CIRCULATORS

Pumped liquid temperature range: from -10 °C to +110 °C - Maximum operating pressure: 16 bar (1600 kPa)

EVOPLUS B 80/360.80 M

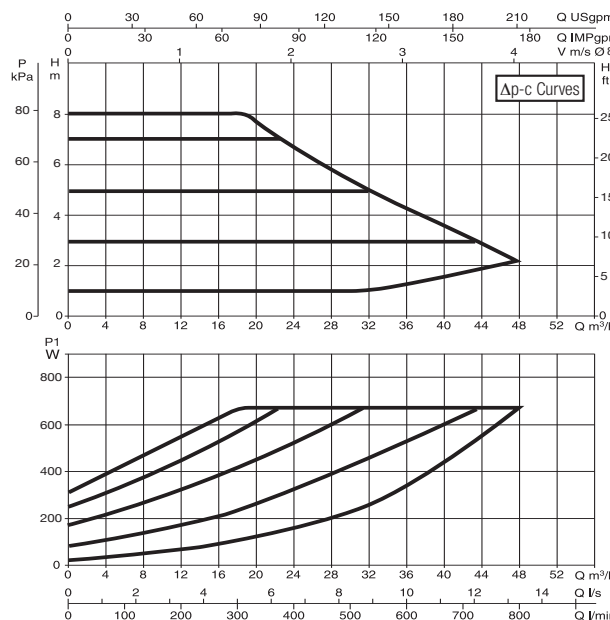
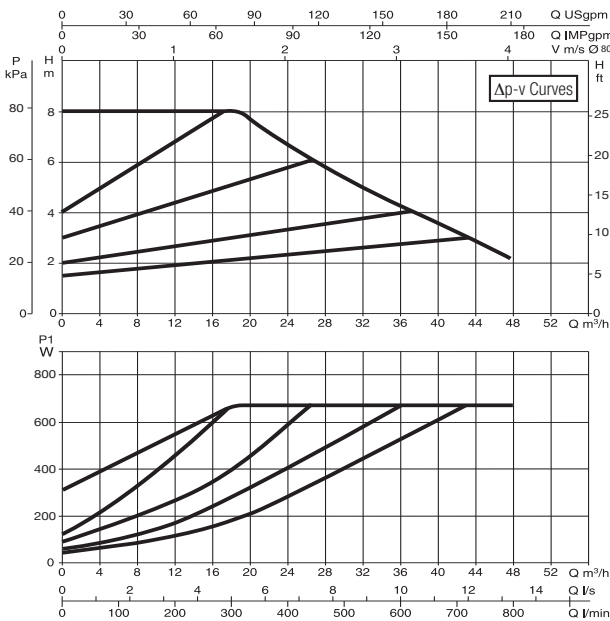

EVOPLUS B 100/360.80 M

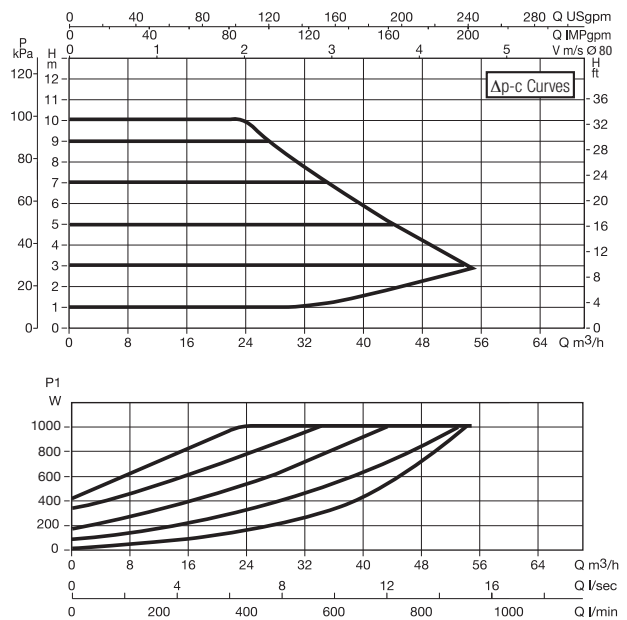
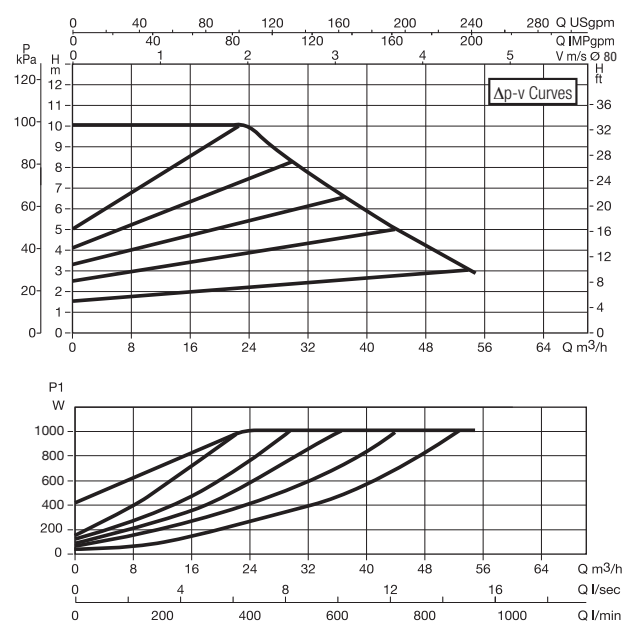

The curves are based on kinematic viscosity values = 1 mm²/s and density equal to 1000 kg/m³. Curve tolerance according to ISO 9906. Fixed speed curves available on the DNA.

MODEL	CENTRE DISTANCE mm	COUNTERFLANGES ON REQUEST	POWER INPUT 50/60 Hz	P1 MAX W	In A	EEI*	MINIMUM SUCTION PRESSURE			WEIGHT Kg
							t°	90°	100°	
EVOPLUS B 80/360.80 M	360	DN80 PN 10	220/240 V	670	3	EEI ≤ 0,20	m.c.w.	20	25	32
EVOPLUS B 100/360.80 M	360	DN80 PN 10	220/240 V	1005	4,5	EEI ≤ 0,19	m.c.w.	20	25	32,2

*The parameter of reference for the more efficient circulators is EEI ≤ 0,20.

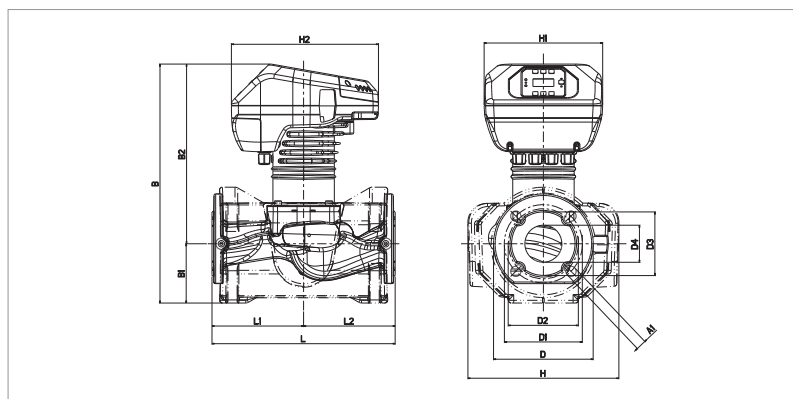

L	L1	L2	A1	B	B1	B2	D
360	180	180	19	360	180	180	19

D1	D3	D4	H	H1	H2
160	132	80	279	220	273

EVOPLUS - WET ROTOR ELECTRONIC CIRCULATORS

Pumped liquid temperature range: from -10 °C to +110 °C - Maximum operating pressure: 16 bar (1600 kPa)

EVOPLUS B 120/360.80 M

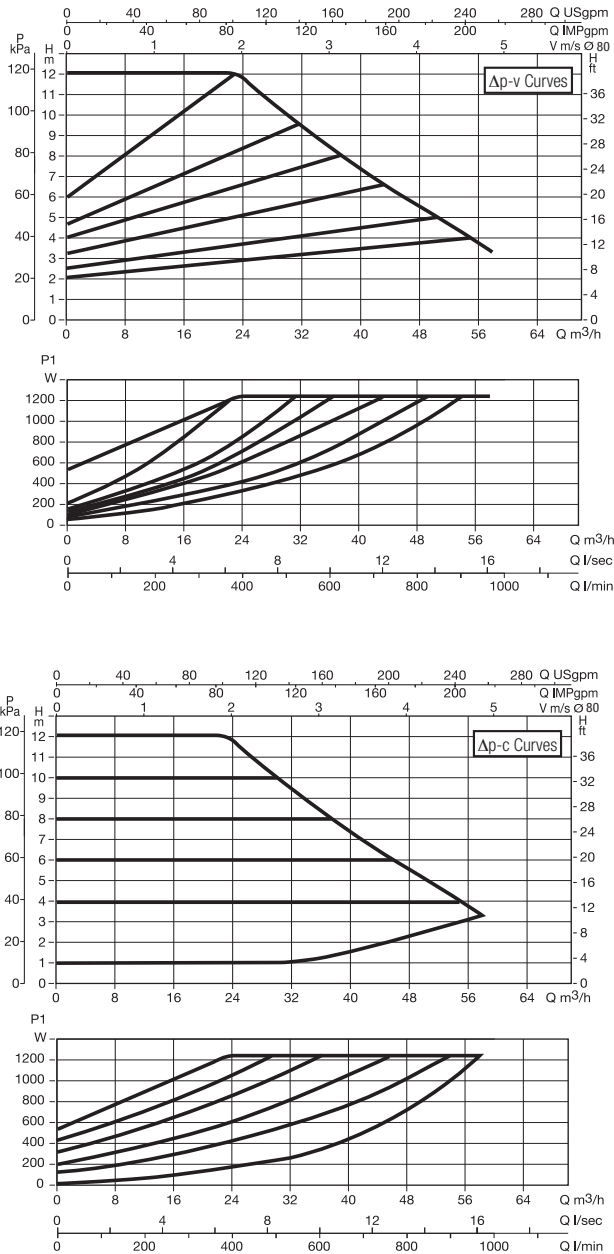

The curves are based on kinematic viscosity values = 1 mm²/s and density equal to 1000 kg/m³. Curve tolerance according to ISO 9906. Fixed speed curves available on the DNA.

MODEL	CENTRE DISTANCE mm	COUNTERFLANGES ON REQUEST	POWER INPUT 50/60 Hz	P1 MAX W	In A	EEI*	MINIMUM SUCTION PRESSURE			WEIGHT Kg
							t°	90°	100°	
EVOPLUS B 120/360.80 M	360	DN80 PN 10	220/240 V	1235	5,5	EEI ≤ 0,19	m.c.w.	20	25	32,2

* The parameter of reference for the more efficient circulators is EEI ≤ 0,20.

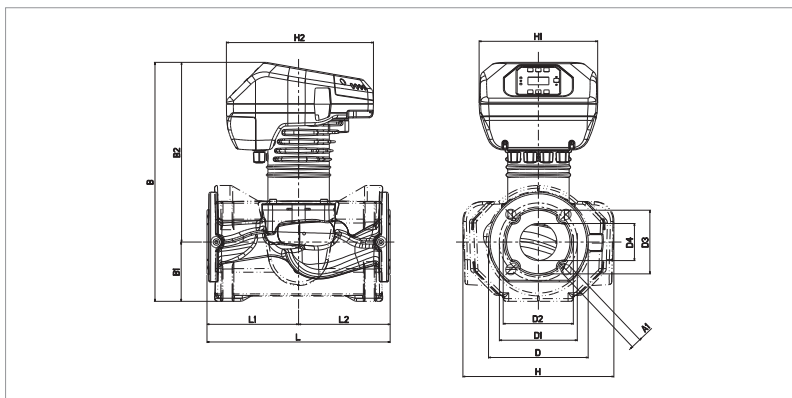

L	L1	L2	A1	B	B1	B2	D
360	180	180	19	446	106	340	200

D1	D3	D4	H	H1	H2
160	132	80	279	220	273

EVOPLUS - WET ROTOR ELECTRONIC CIRCULATORS

Pumped liquid temperature range: from -10 °C to +110 °C - Maximum operating pressure: 16 bar (1600 kPa)

EVOPLUS B 40/450,100 M

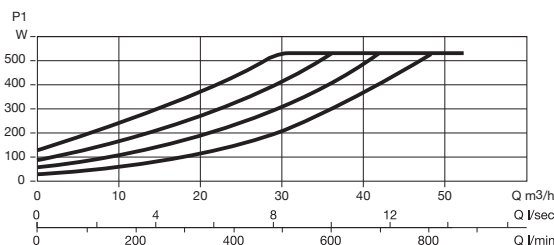
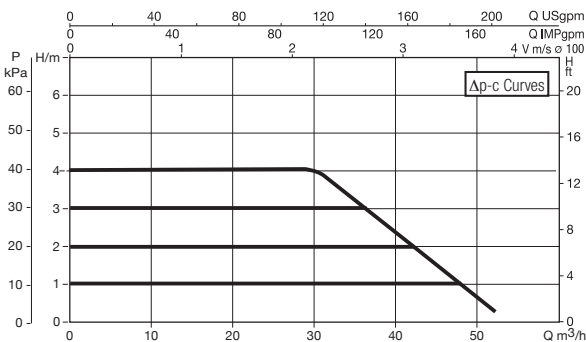
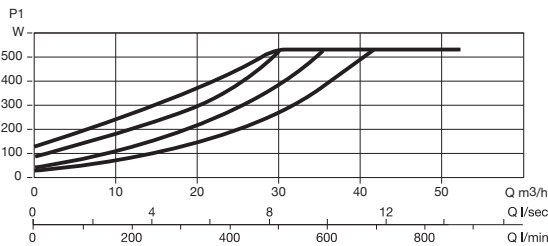
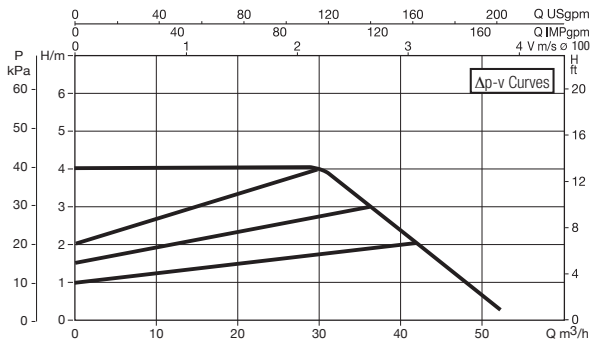

EVOPLUS B 60/450,100 M

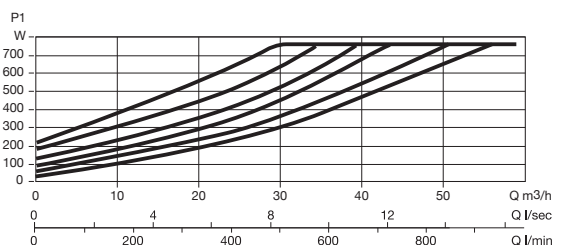
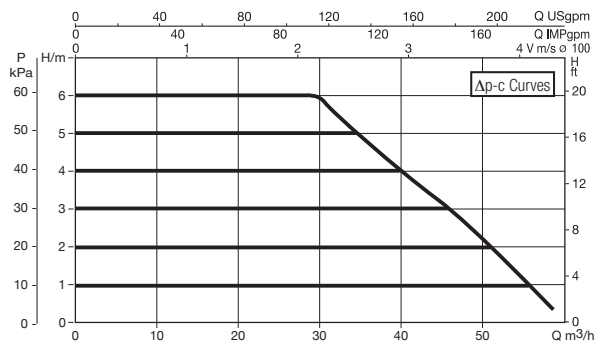
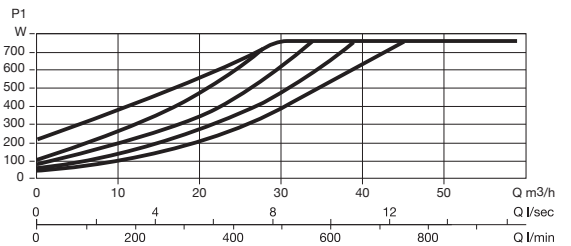
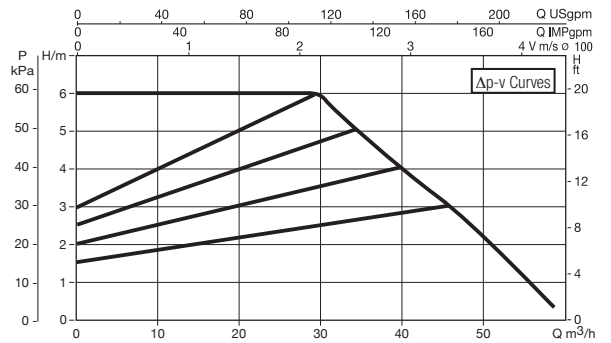

The curves are based on kinematic viscosity values = 1 mm²/s and density equal to 1000 kg/m³. Curve tolerance according to ISO 9906. Fixed speed curves available on the DNA.

MODEL	CENTRE DISTANCE mm	COUNTERFLANGES ON REQUEST	POWER INPUT 50/60 Hz	P1 MAX W	In A	EEI*	MINIMUM SUCTION PRESSURE			WEIGHT Kg
							t°	90°	100°	
EVOPLUS B 40/450.100 M	450	DN100 PN 10	220/240 V	530	2,5	EEI ≤ 0,19	m.c.w.	20	25	37,5
EVOPLUS B 60/450.100 M	450	DN100 PN 10	220/240 V	760	3,5	EEI ≤ 0,18	m.c.w.	20	25	37,5

* The parameter of reference for the more efficient circulators is EEI ≤ 0,20.

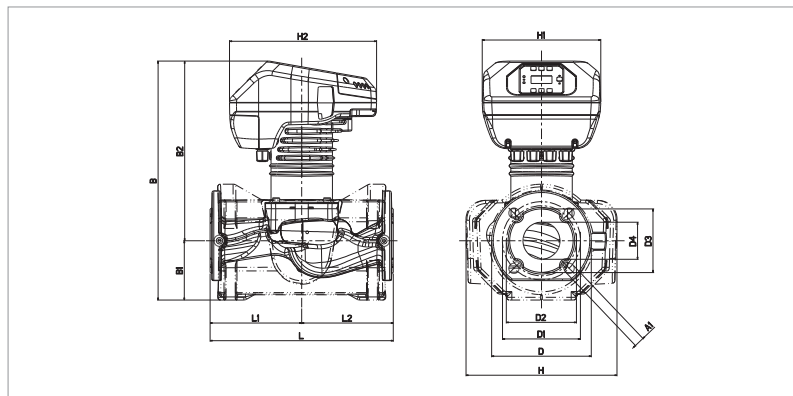

L	L1	L2	A1	B	B1	B2	D
450	225	225	19	463	110	353	220

D1	D3	D4	H	H1	H2
180	156	105	292	220	273

EVOPLUS - WET ROTOR ELECTRONIC CIRCULATORS

Pumped liquid temperature range: from -10 °C to +110 °C - Maximum operating pressure: 16 bar (1600 kPa)

EVOPLUS B 80/450,100 M

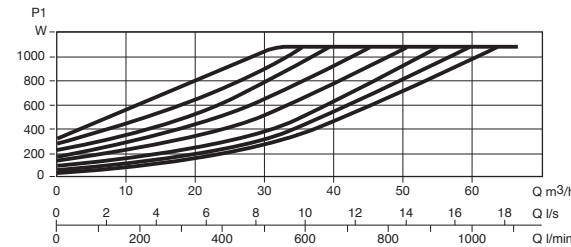
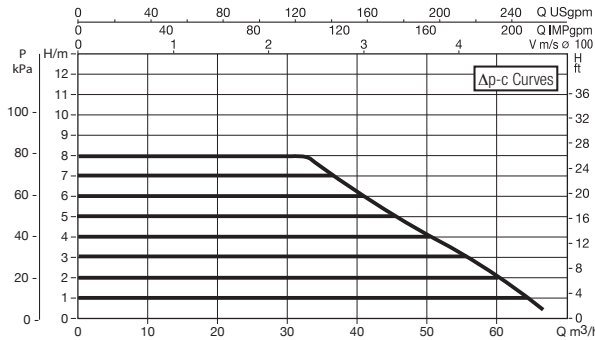
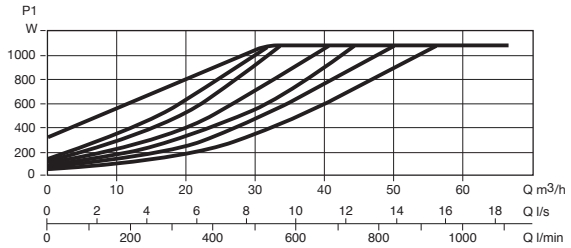
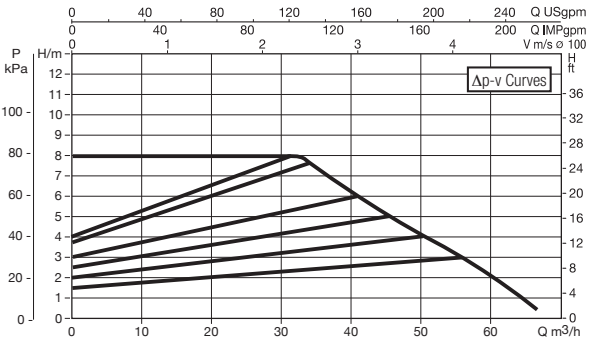

EVOPLUS B 100/450,100 M

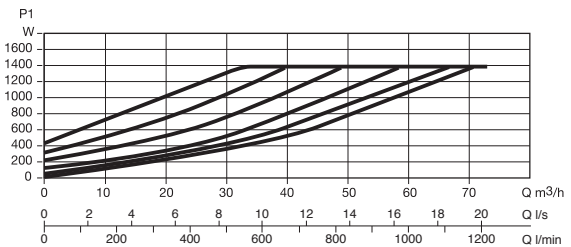
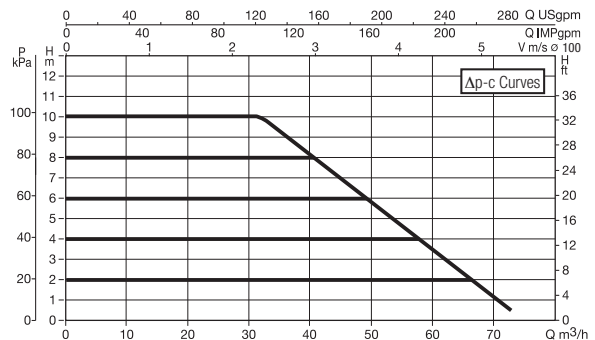
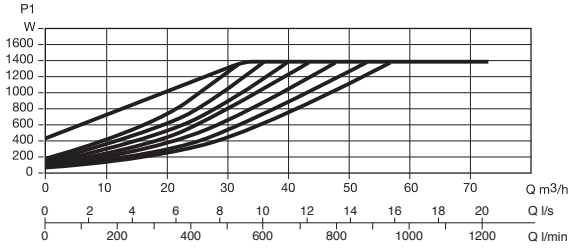
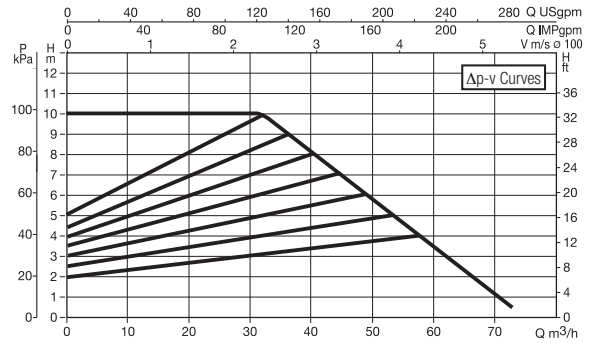

The curves are based on kinematic viscosity values = 1 mm²/s and density equal to 1000 kg/m³. Curve tolerance according to ISO 9906. Fixed speed curves available on the DNA.

MODEL	CENTRE DISTANCE mm	COUNTERFLANGES ON REQUEST	POWER INPUT 50/60 Hz	P1 MAX W	In A	EEI*	MINIMUM SUCTION PRESSURE			WEIGHT Kg
							t°	90°	100°	
EVOPLUS B 80/450.100 M	450	DN100 PN 10	220/240 V	1080	4,8	EEI ≤ 0,18	m.c.w.	20	25	36,6
EVOPLUS B 100/450.100 M	450	DN100 PN 10	220/240 V	1380	6	EEI ≤ 0,19	m.c.w.	20	25	36,8

* The parameter of reference for the more efficient circulators is EEI ≤ 0,20.

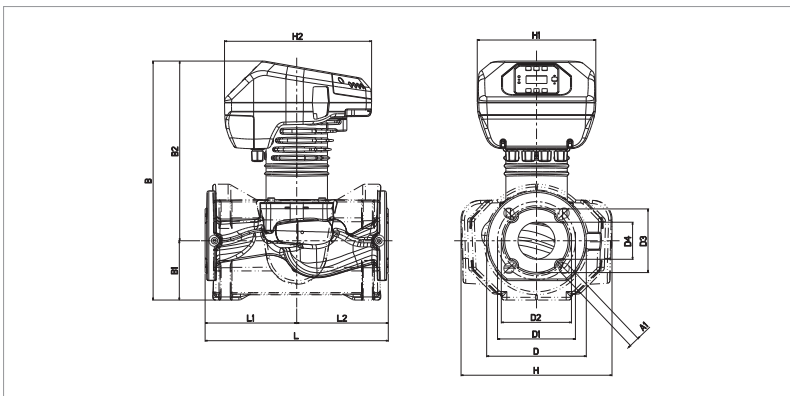

L	L1	L2	A1	B	B1	B2	D
450	225	225	19	463	110	353	220

D1	D3	D4	H	H1	H2
180	156	105	292	220	273

EVOPLUS - WET ROTOR ELECTRONIC CIRCULATORS

Pumped liquid temperature range: from -10 °C to +110 °C - Maximum operating pressure: 16 bar (1600 kPa)

EVOPLUS B 120/450.100 M

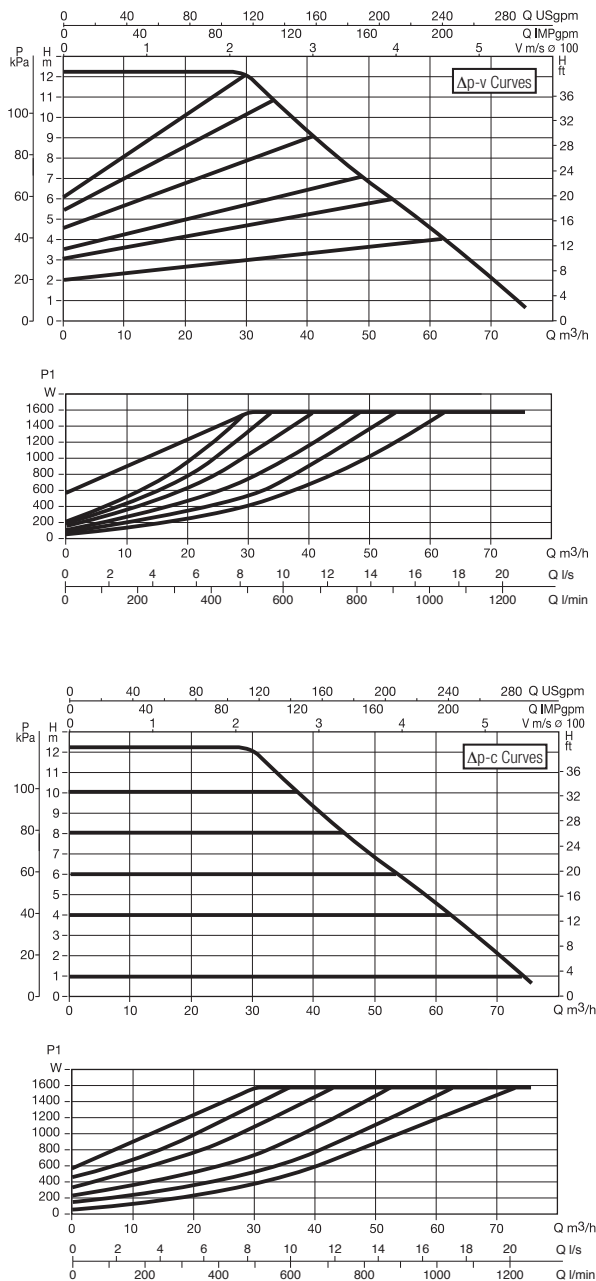

The curves are based on kinematic viscosity values = 1 mm²/s and density equal to 1000 kg/m³. Curve tolerance according to ISO 9906. Fixed speed curves available on the DNA.

MODEL	CENTRE DISTANCE mm	COUNTERFLANGES ON REQUEST	POWER INPUT 50/60 Hz	P1 MAX W	In A	EEI*	MINIMUM SUCTION PRESSURE			WEIGHT Kg
							t°	90°	100°	
EVOPLUS B 120/450.100 M	450	DN100 PN 10	220/240 V	1560	7	EEI ≤ 0,19	m.c.w.	20	25	36,3

* The parameter of reference for the more efficient circulators is EEI ≤ 0,20.

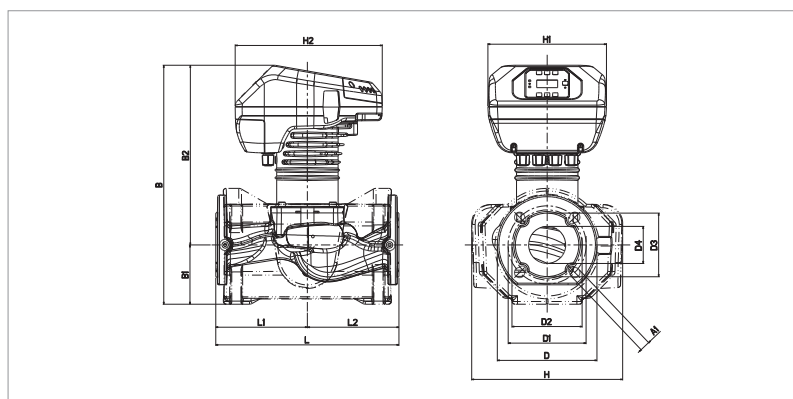

L	L1	L2	A1	B	B1	B2	D
450	225	225	19	463	110	353	220

D1	D3	D4	H	H1	H2
180	156	105	292	220	273

EVOPLUS - WET ROTOR ELECTRONIC CIRCULATORS

Pumped liquid temperature range: from -10 °C to +110 °C - Maximum operating pressure: 16 bar (1600 kPa)

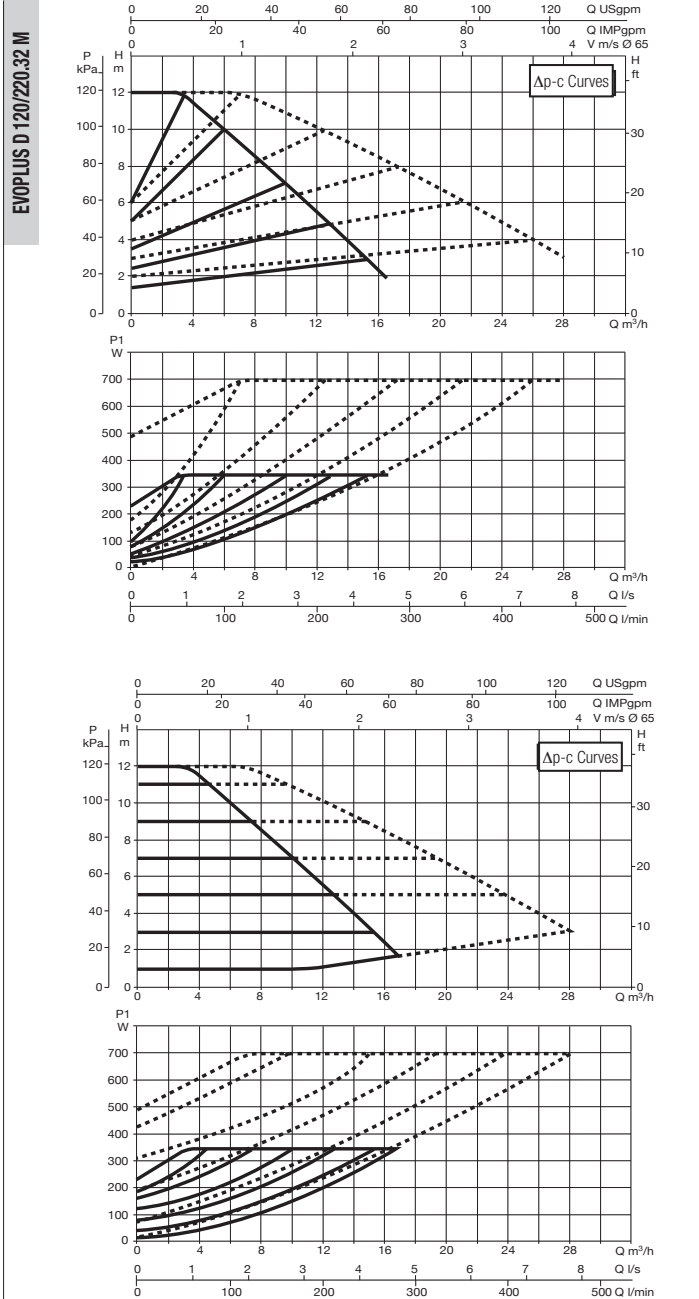

The curves are based on kinematic viscosity values = 1 mm²/s and density equal to 1000 kg/m³. Curve tolerance according to ISO 9906. Fixed speed curves available on the DNA.

MODEL	CENTRE DISTANCE mm	COUNTERFLANGES ON REQUEST	POWER INPUT 50/60 Hz	P1 MAX W	In A	EEI*	MINIMUM SUCTION PRESSURE			WEIGHT Kg
							t°	90°	100°	
EVOPLUS D 120/220.32 M	220	DN32 PN 6	220/240 V	340	1,7	EEI ≤ 0,22	m.c.w.	20	25	36,2

* The parameter of reference for the more efficient circulators is EEI ≤ 0,20.

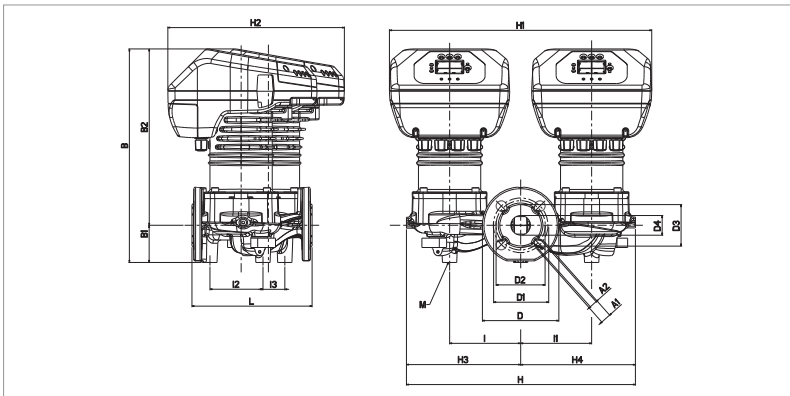

L	A1	A2	B	B1	B2	D	D1	D2	D3	D4
220	19	14	391	68	323	140	100	90	76	36

I	I1	I2	I3	M	H	H1	H2	H3	H4
130	130	97	40	M12	419	480	323	209	210

EVOPLUS - WET ROTOR ELECTRONIC CIRCULATORS

Pumped liquid temperature range: from -10 °C to +110 °C - Maximum operating pressure: 16 bar (1600 kPa)

EVOPLUS D 40/220.40 M

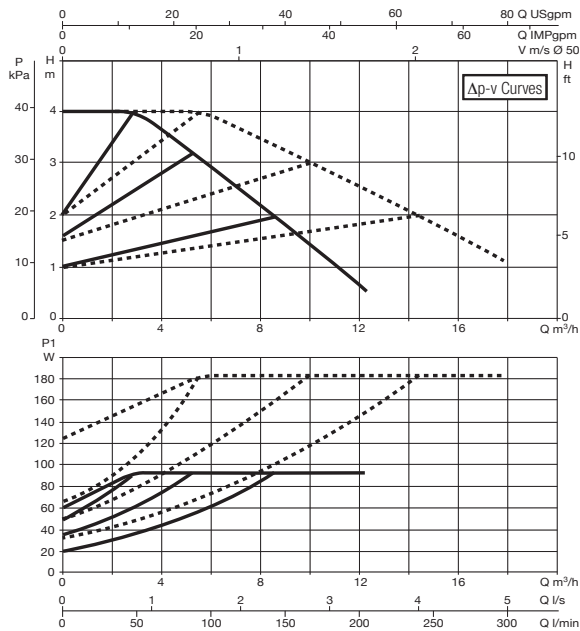

EVOPLUS D 60/220.40 M

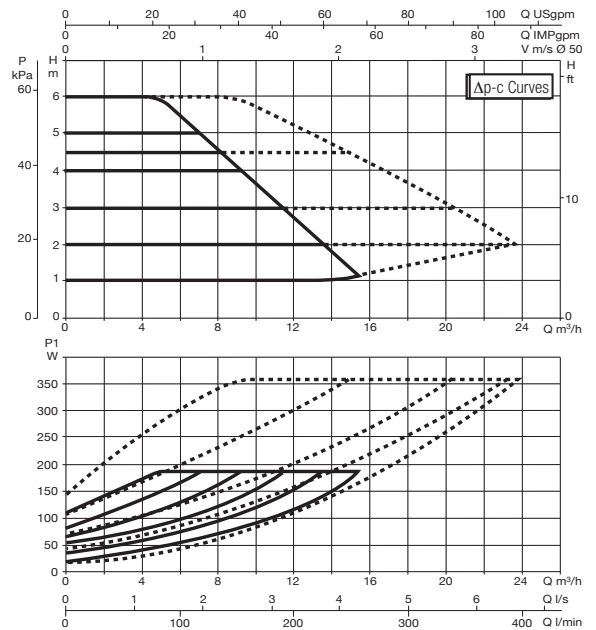
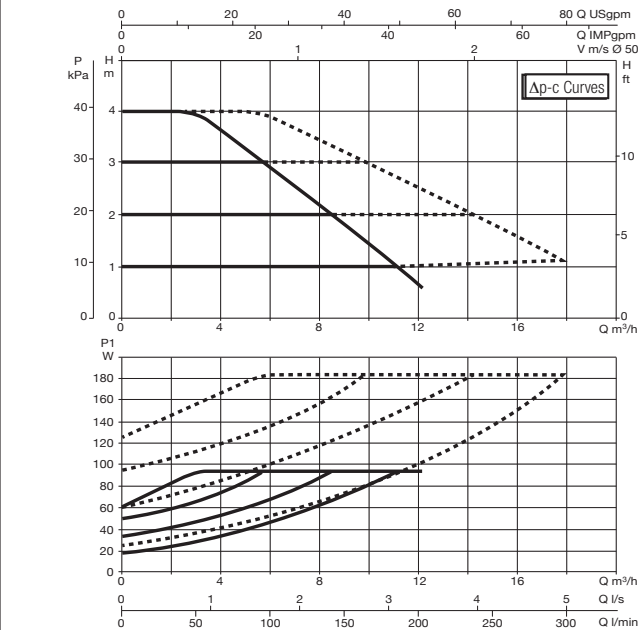
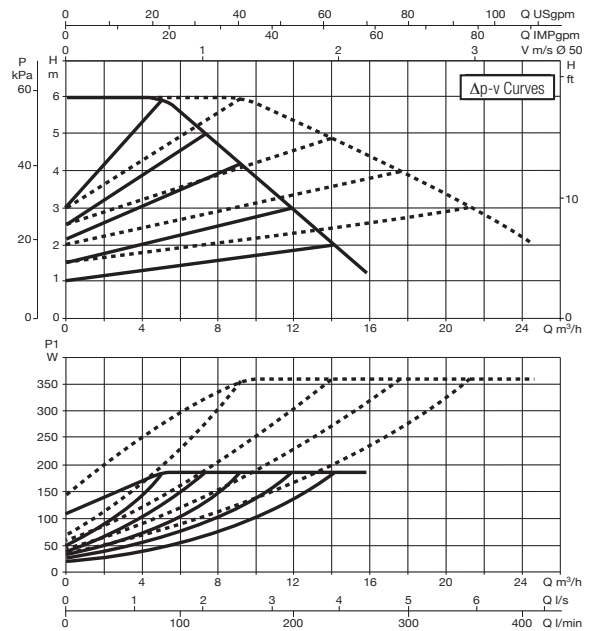

The curves are based on kinematic viscosity values = 1 mm²/s and density equal to 1000 kg/m³. Curve tolerance according to ISO 9906. Fixed speed curves available on the DNA.

MODEL	CENTRE DISTANCE mm	COUNTERFLANGES ON REQUEST	POWER INPUT 50/60 Hz	P1 MAX W	In A	EEI*	MINIMUM SUCTION PRESSURE			WEIGHT Kg
							t°	90°	100°	
EVOPLUS D 40/220.40 M	220	DN40 PN 10	220/240 V	90	0,7	EEI ≤ 0,23	m.c.w.	20	25	38,6
EVOPLUS D 60/220.40 M	220	DN40 PN 10	220/240 V	175	1	EEI ≤ 0,23	m.c.w.	20	25	38,6

* The parameter of reference for the more efficient circulators is EEI ≤ 0,20.

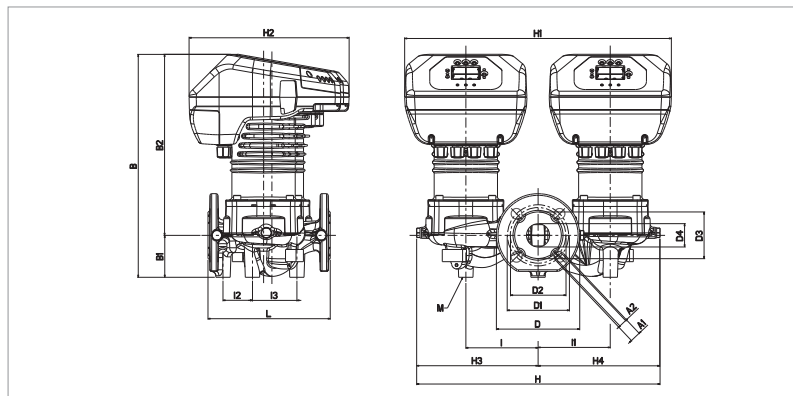

L	A1	A2	B	B1	B2	D	D1	D2	D3	D4
220	19	14	436	75	361	150	110	100	84	42

I	I1	I2	I3	M	H	H1	H2	H3	H4
130	130	53	80	M12	438	480	288	219	218

EVOPLUS - WET ROTOR ELECTRONIC CIRCULATORS

Pumped liquid temperature range: from -10 °C to +110 °C - Maximum operating pressure: 16 bar (1600 kPa)

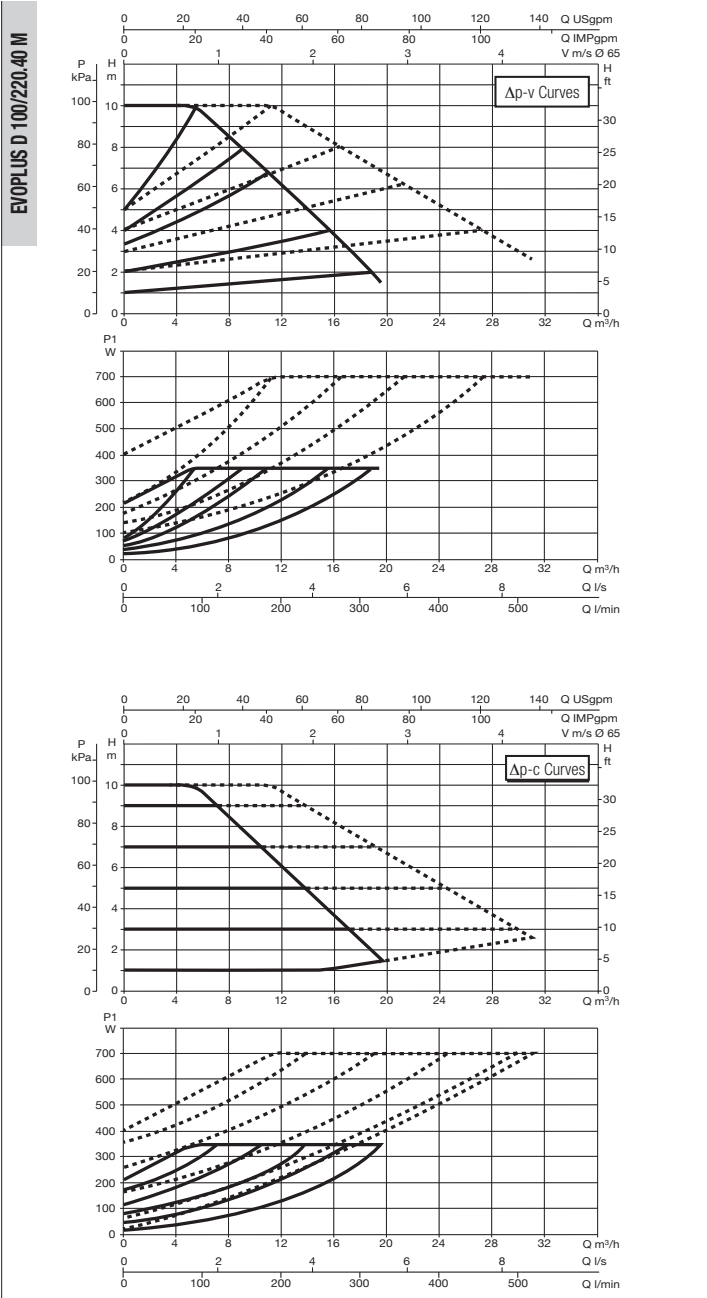
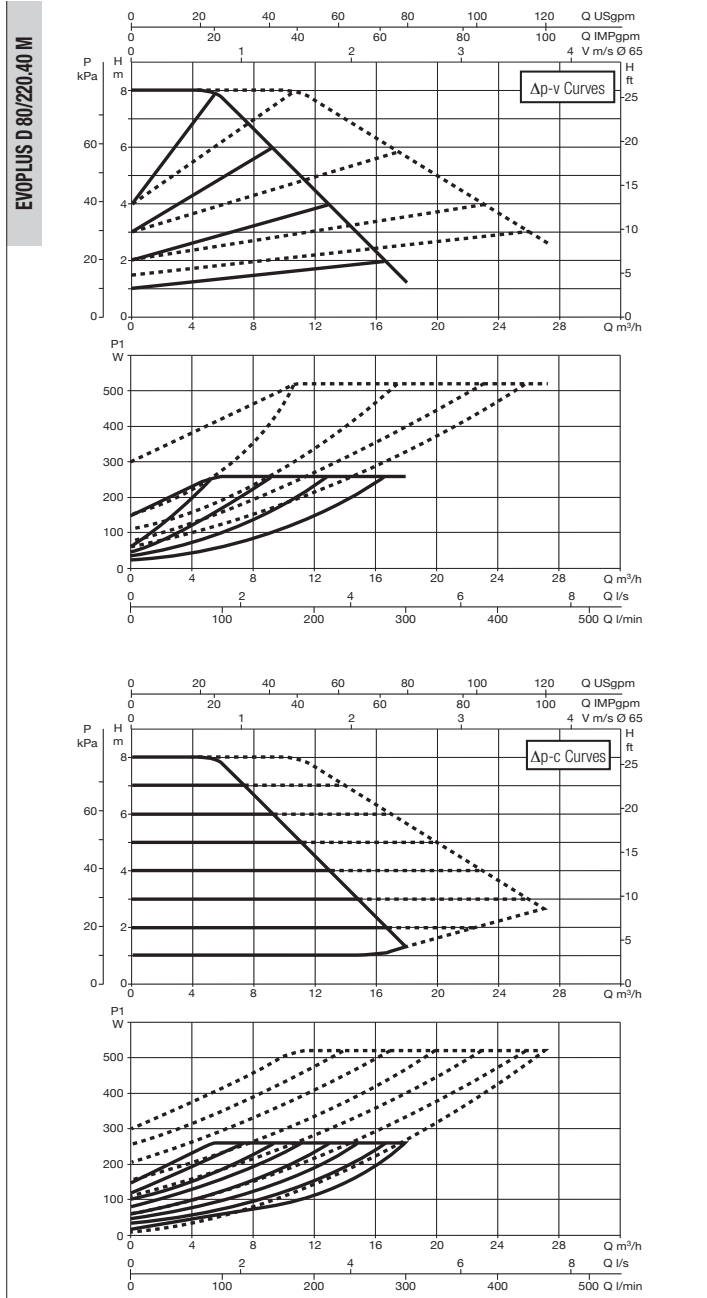

The curves are based on kinematic viscosity values = 1 mm²/s and density equal to 1000 kg/m³. Curve tolerance according to ISO 9906. Fixed speed curves available on the DNA.

MODEL	CENTRE DISTANCE mm	COUNTERFLANGES ON REQUEST	POWER INPUT 50/60 Hz	P1 MAX W	In A	EEI*	MINIMUM SUCTION PRESSURE			WEIGHT Kg
							t°	90°	100°	
EVOPLUS D 80/220.40 M	220	DN40 PN 10	220/240 V	260	1,35	EEI ≤ 0,23	m.c.w.	20	25	38,6
EVOPLUS D 100/220.40 M	220	DN40 PN 10	220/240 V	350	1,75	EEI ≤ 0,23	m.c.w.	20	25	38,6

* The parameter of reference for the more efficient circulators is EEI ≤ 0,20.

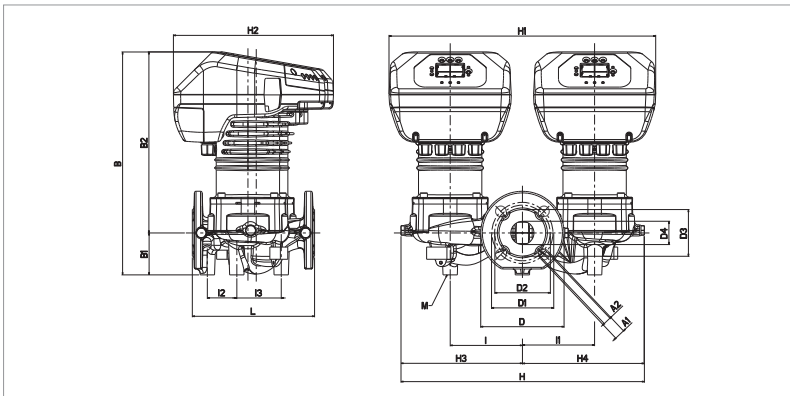

L	A1	A2	B	B1	B2	D	D1	D2	D3	D4
220	19	14	436	75	361	150	110	100	84	42

I	I1	I2	I3	M	H	H1	H2	H3	H4
130	130	53	80	M12	438	480	288	219	218

EVOPLUS - WET ROTOR ELECTRONIC CIRCULATORS

Pumped liquid temperature range: from -10 °C to +110 °C - Maximum operating pressure: 16 bar (1600 kPa)

EVOPLUS D 120/250.40 M

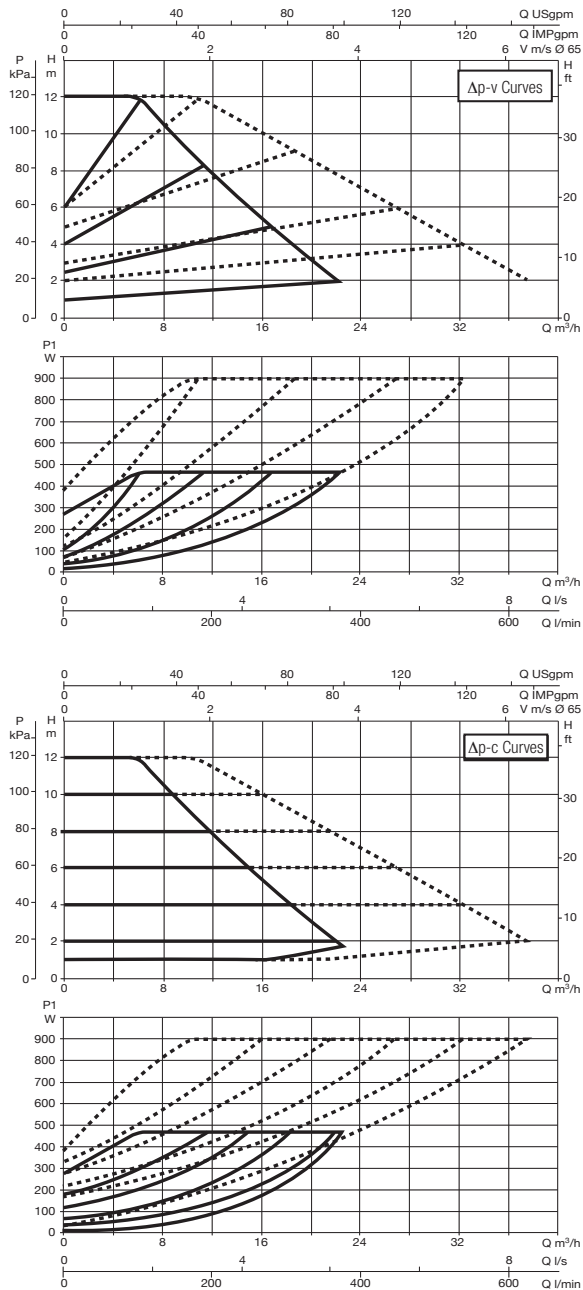

EVOPLUS D 150/250.40 M

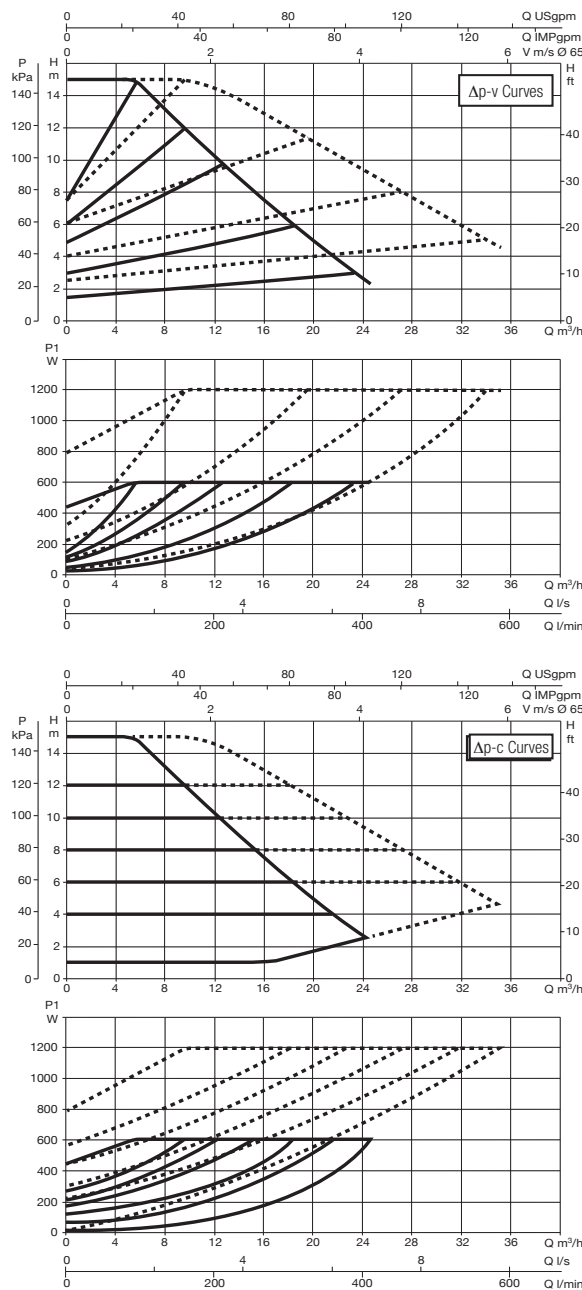

WET ROTOR ELECTRONIC CIRCULATORS

The curves are based on kinematic viscosity values = 1 mm²/s and density equal to 1000 kg/m³. Curve tolerance according to ISO 9906. Fixed speed curves available on the DNA.

MODEL	CENTRE DISTANCE mm	COUNTERFLANGES ON REQUEST	POWER INPUT 50/60 Hz	P1 MAX W	In A	EEI*	MINIMUM SUCTION PRESSURE			WEIGHT Kg
							t°	90°	100°	
EVOPLUS D 120/250.40 M	250	DN40 PN 10	220/240 V	465	2,2	EEI ≤ 0,23	m.c.w.	20	25	38,8
EVOPLUS D 150/250.40 M	250	DN40 PN 10	220/240 V	610	2,9	EEI ≤ 0,23	m.c.w.	20	25	38,8

* The parameter of reference for the more efficient circulators is EEI ≤ 0,20.

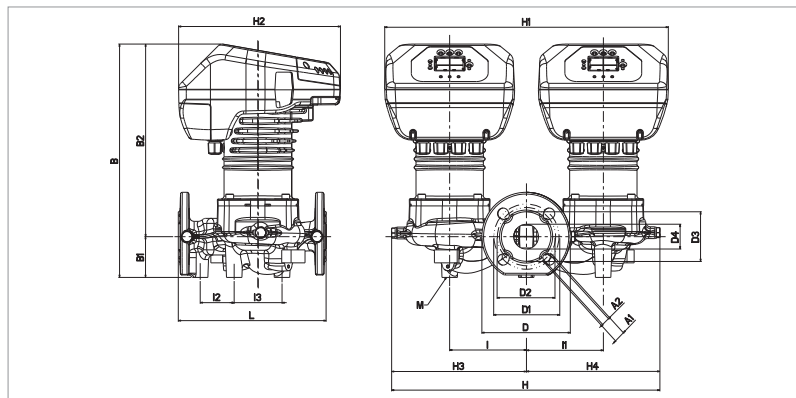

L	A1	A2	B	B1	B2	D	D1	D2	D3	D4
250	19	14	395	69	326	150	110	100	84	42

I	I1	I2	I3	M	H	H1	H2	H3	H4
130	130	58	81	M12	454	480	274	228	226

EVOPLUS - WET ROTOR ELECTRONIC CIRCULATORS

Pumped liquid temperature range: from -10 °C to +110 °C - Maximum operating pressure: 16 bar (1600 kPa)

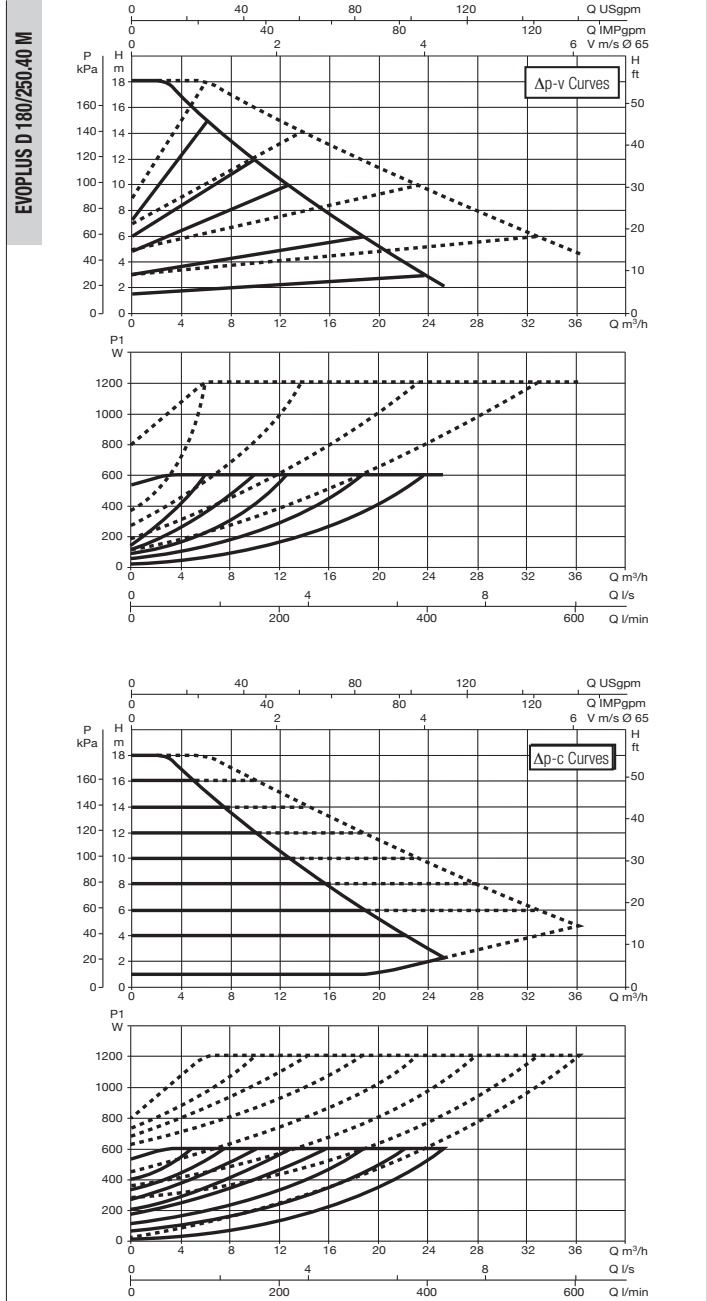

The curves are based on kinematic viscosity values = 1 mm²/s and density equal to 1000 kg/m³. Curve tolerance according to ISO 9906. Fixed speed curves available on the DNA.

MODEL	CENTRE DISTANCE mm	COUNTERFLANGES ON REQUEST	POWER INPUT 50/60 Hz	P1 MAX W	In A	EEI*	MINIMUM SUCTION PRESSURE			WEIGHT Kg
							t°	90°	100°	
EVOPLUS D 180/250.40 M	250	DN40 PN 10	220/240 V	610	2,9	EEI ≤ 0,23	m.c.w.	20	25	38,8

* The parameter of reference for the more efficient circulators is EEI ≤ 0,20.

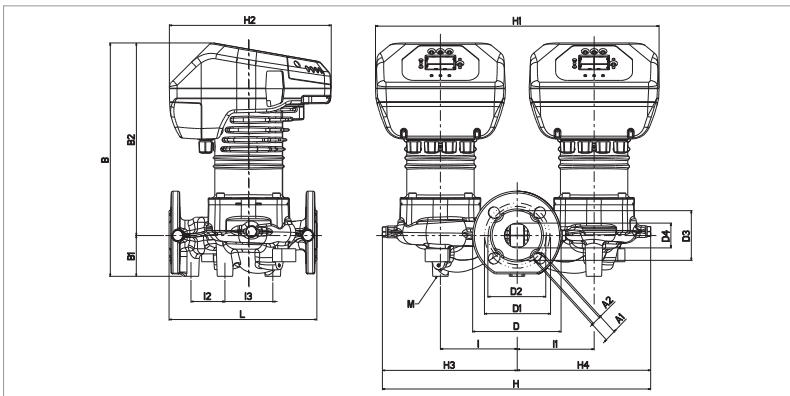

L	A1	A2	B	B1	B2	D	D1	D2	D3	D4
250	19	14	395	69	326	150	110	100	84	42

I	I1	I2	I3	M	H	H1	H2	H3	H4
130	130	58	81	M12	454	480	274	228	226

EVOPLUS - WET ROTOR ELECTRONIC CIRCULATORS

Pumped liquid temperature range: from -10 °C to +110 °C - Maximum operating pressure: 16 bar (1600 kPa)

EVOPLUS D 40/240.50 M

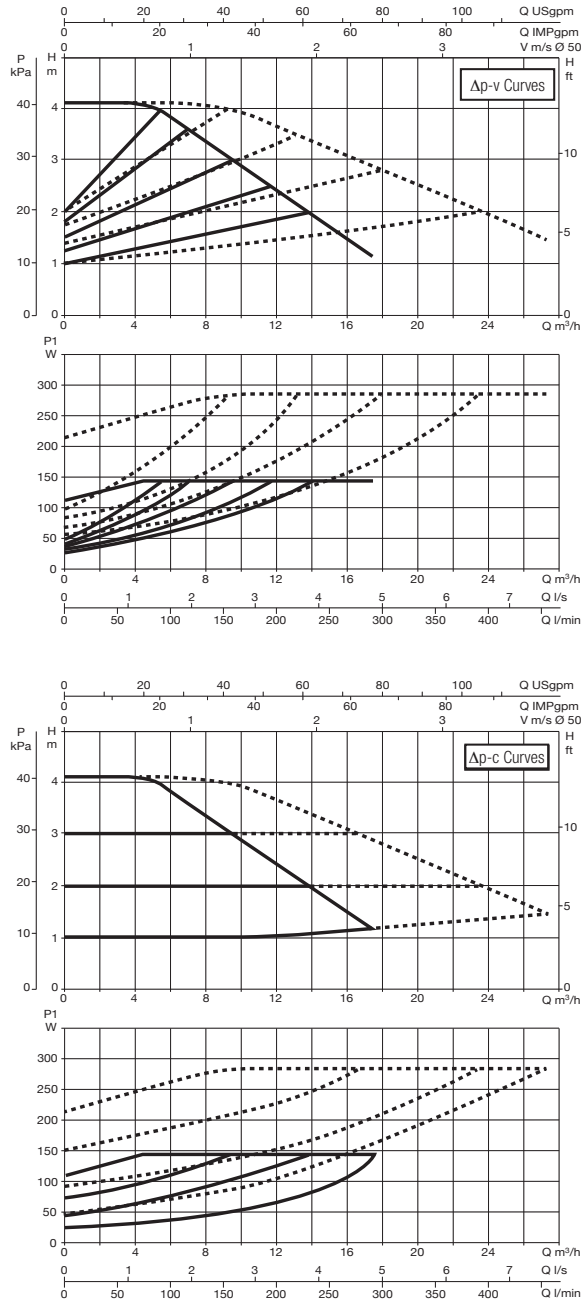

EVOPLUS D 60/240.50 M

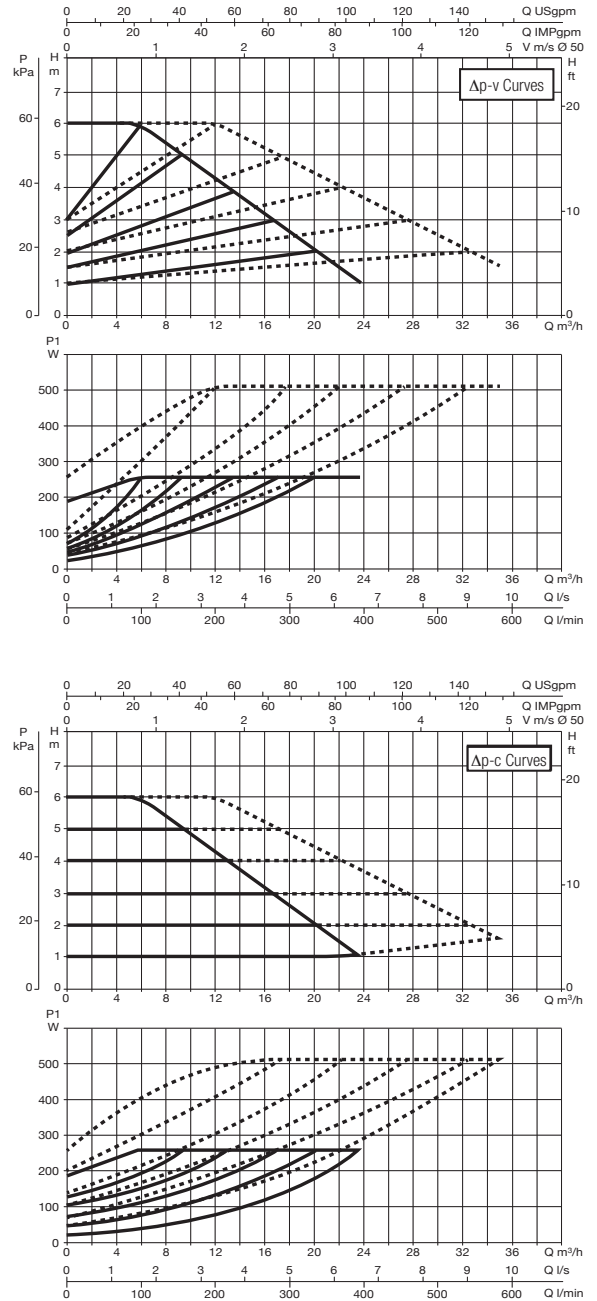

The curves are based on kinematic viscosity values = 1 mm²/s and density equal to 1000 kg/m³. Curve tolerance according to ISO 9906. Fixed speed curves available on the DNA.

MODEL	CENTRE DISTANCE mm	COUNTERFLANGES ON REQUEST	POWER INPUT 50/60 Hz	P1 MAX W	In A	EEI*	MINIMUM SUCTION PRESSURE			WEIGHT Kg
							t°	90°	100°	
EVOPLUS D 40/240.50 M	240	DN50 PN 10	220/240 V	140	0,87	EEI ≤ 0,23	m.c.w.	20	25	40
EVOPLUS D 60/240.50 M	240	DN50 PN 10	220/240 V	260	1,35	EEI ≤ 0,22	m.c.w.	20	25	40

* The parameter of reference for the more efficient circulators is EEI ≤ 0,20.

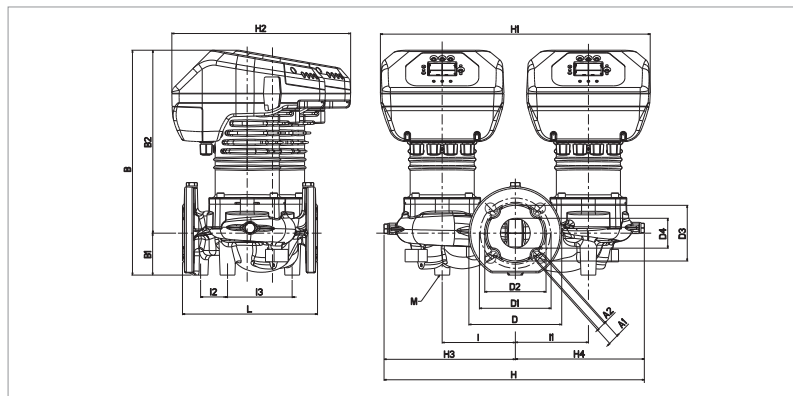

L	A1	A2	B	B1	B2	D	D1	D2	D3	D4
240	19	14	400	75	325	165	125	110	99	53

I	I1	I2	I3	M	H	H1	H2	H3	H4
130	130	48	115	M12	463	480	318	233	230

EVOPLUS - WET ROTOR ELECTRONIC CIRCULATORS

Pumped liquid temperature range: from -10 °C to +110 °C - Maximum operating pressure: 16 bar (1600 kPa)

EVOPLUS D 80/240.50 M

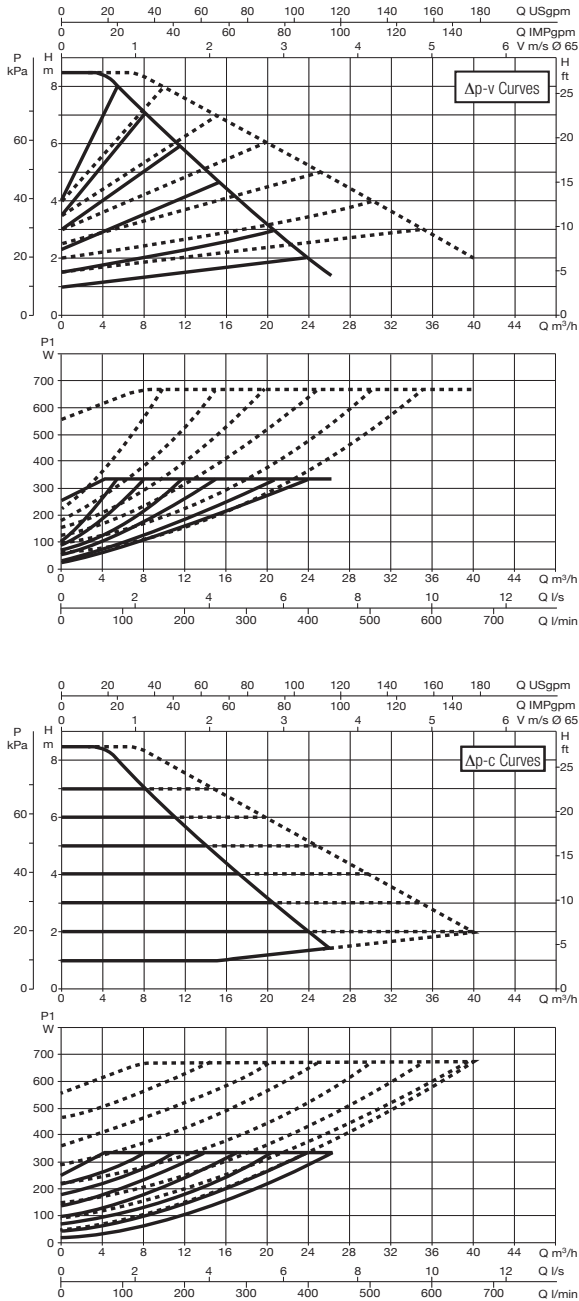

The curves are based on kinematic viscosity values = 1 mm²/s and density equal to 1000 kg/m³. Curve tolerance according to ISO 9906. Fixed speed curves available on the DNA.

MODEL	CENTRE DISTANCE mm	COUNTERFLANGES ON REQUEST	POWER INPUT 50/60 Hz	P1 MAX W	In A	EEI*	MINIMUM SUCTION PRESSURE			WEIGHT Kg
							t°	90°	100°	
EVOPLUS D 80/240.50 M	240	DN50 PN 10	220/240 V	330	1,7	EEI ≤ 0,22	m.c.w.	20	25	40

* The parameter of reference for the more efficient circulators is EEI ≤ 0,20.

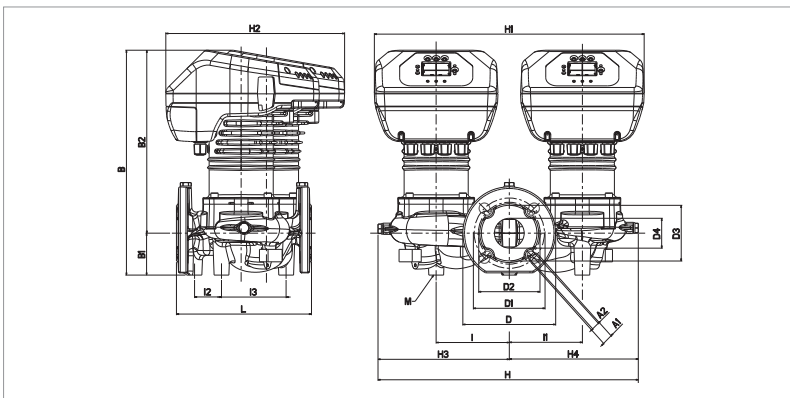

L	A1	A2	B	B1	B2	D	D1	D2	D3	D4
240	19	14	400	75	325	165	125	110	99	53

I	I1	I2	I3	M	H	H1	H2	H3	H4
130	130	48	115	M12	463	480	318	233	230

EVOPLUS - WET ROTOR ELECTRONIC CIRCULATORS

Pumped liquid temperature range: from -10 °C to +110 °C - Maximum operating pressure: 16 bar (1600 kPa)

EVOPLUS D 100/280.50 M

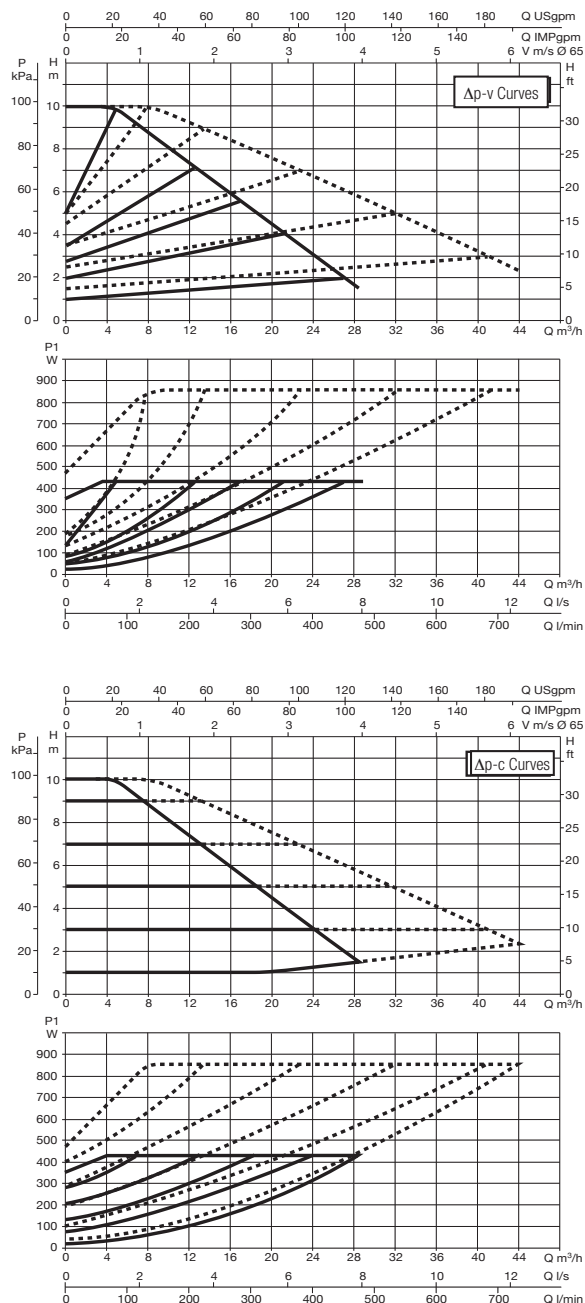

EVOPLUS D 120/280.50 M

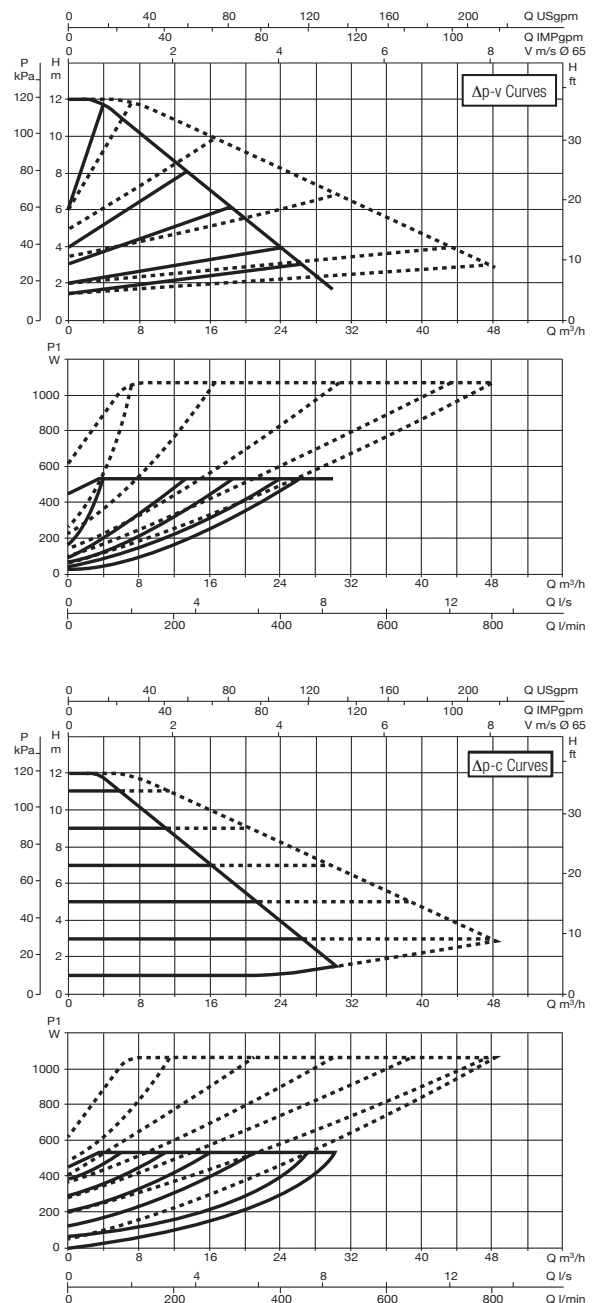

The curves are based on kinematic viscosity values = 1 mm²/s and density equal to 1000 kg/m³. Curve tolerance according to ISO 9906. Fixed speed curves available on the DNA.

MODEL	CENTRE DISTANCE mm	COUNTERFLANGES ON REQUEST	POWER INPUT 50/60 Hz	P1 MAX W	In A	EEI*	MINIMUM SUCTION PRESSURE			WEIGHT Kg
							t°	90°	100°	
EVOPLUS D 100/280.50 M	280	DN50 PN 10	220/240 V	430	2,1	EEI ≤ 0,22	m.c.w.	20	25	39,4
EVOPLUS D 120/280.50 M	280	DN50 PN 10	220/240 V	530	2,5	EEI ≤ 0,22	m.c.w.	20	25	39,6

* The parameter of reference for the more efficient circulators is EEI ≤ 0,20.

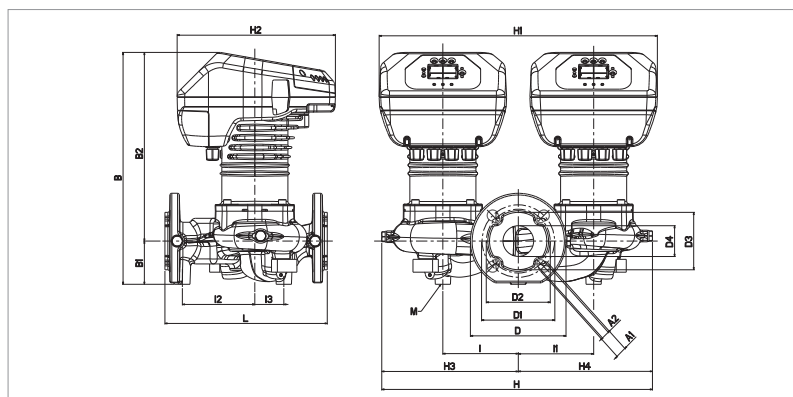

L	A1	A2	B	B1	B2	D	D1	D2	D3	D4
280	19	14	400	75	325	165	125	110	99	53

I	I1	I2	I3	M	H	H1	H2	H3	H4
130	130	125	50	M12	467	480	273	235	232

EVOPLUS - WET ROTOR ELECTRONIC CIRCULATORS

Pumped liquid temperature range: from -10 °C to +110 °C - Maximum operating pressure: 16 bar (1600 kPa)

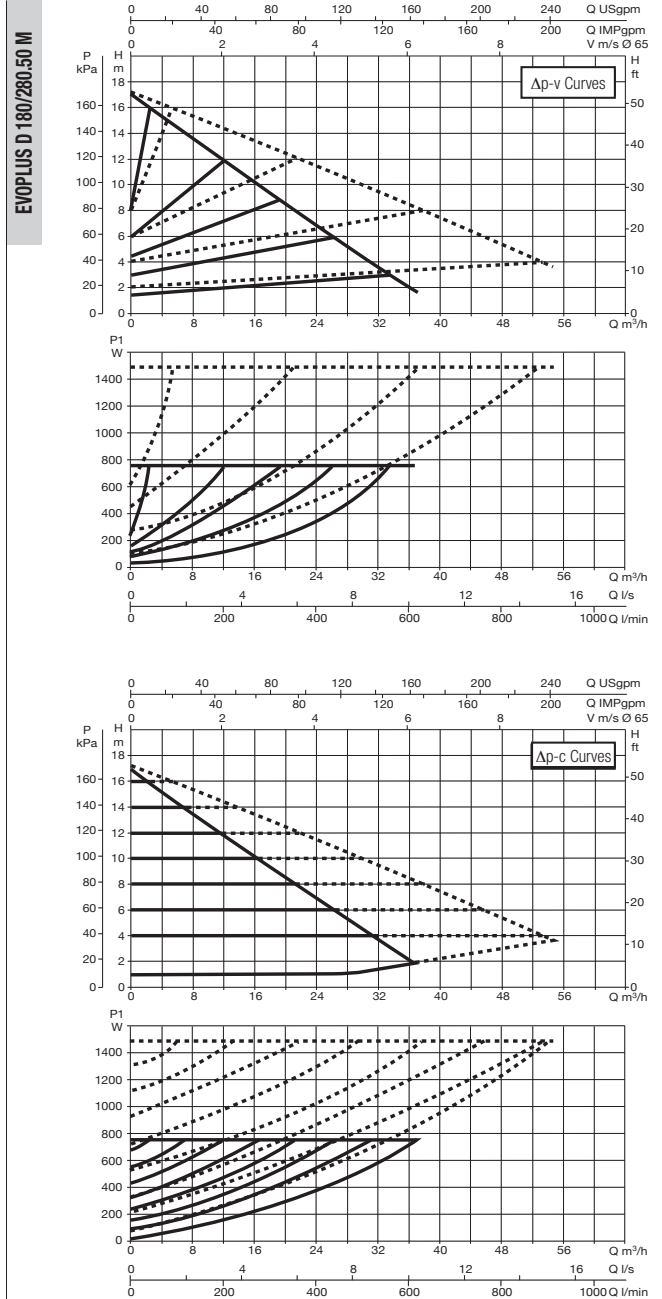
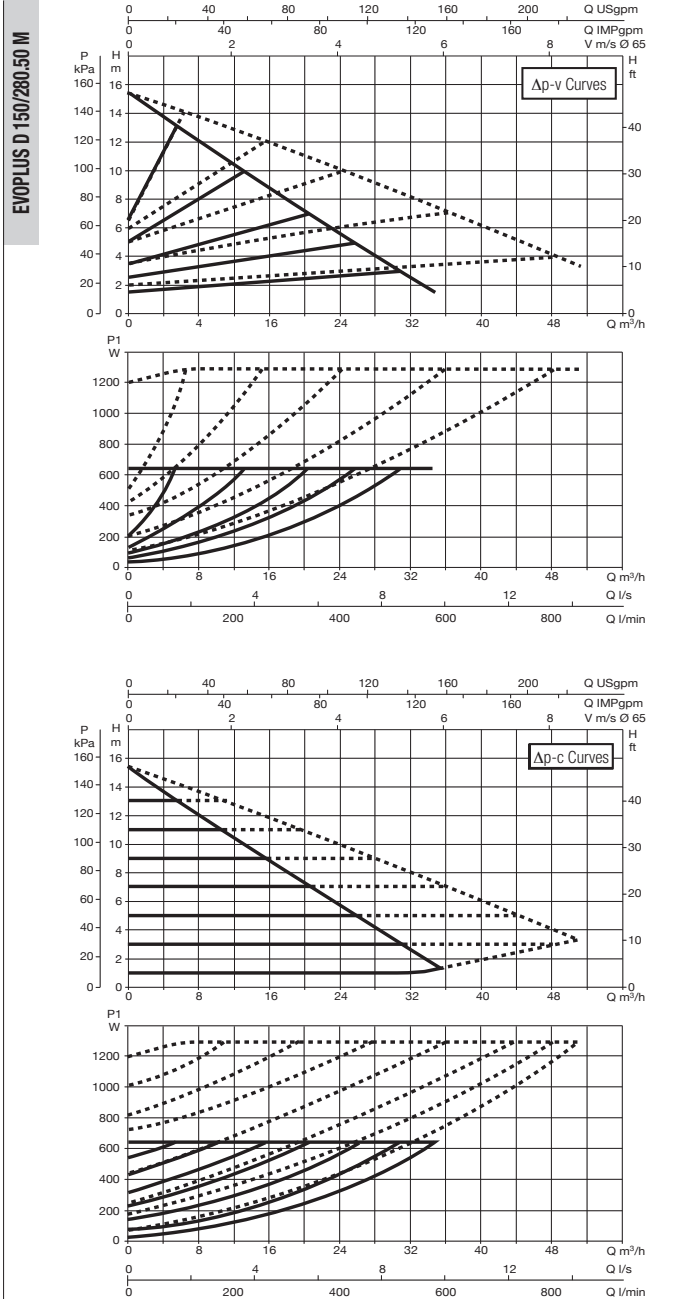

The curves are based on kinematic viscosity values = 1 mm²/s and density equal to 1000 kg/m³. Curve tolerance according to ISO 9906. Fixed speed curves available on the DNA.

MODEL	CENTRE DISTANCE mm	COUNTERFLANGES ON REQUEST	POWER INPUT 50/60 Hz	P1 MAX W	In A	EEI*	MINIMUM SUCTION PRESSURE			WEIGHT Kg
							t°	90°	100°	
EVOPLUS D 150/280.50 M	280	DN50 PN 10	220/240 V	640	3	EEI ≤ 0,21	m.c.w.	20	25	41,6
EVOPLUS D 180/280.50 M	280	DN50 PN 10	220/240 V	750	3,45	EEI ≤ 0,21	m.c.w.	20	25	41,6

* The parameter of reference for the more efficient circulators is EEI ≤ 0,20.

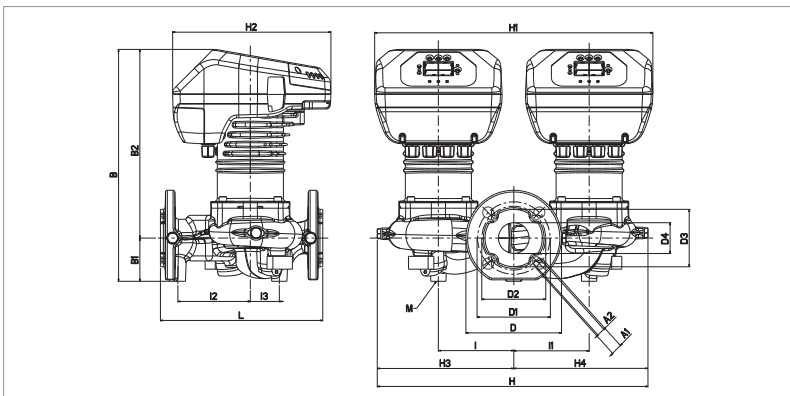

L	A1	A2	B	B1	B2	D	D1	D2	D3	D4
280	19	14	400	75	325	165	125	110	99	53

I	I1	I2	I3	M	H	H1	H2	H3	H4
130	130	125	50	M12	467	480	273	235	232

EVOPLUS - WET ROTOR ELECTRONIC CIRCULATORS

Pumped liquid temperature range: from -10 °C to +110 °C - Maximum operating pressure: 16 bar (1600 kPa)

EVOPLUS D 40/340.65 M

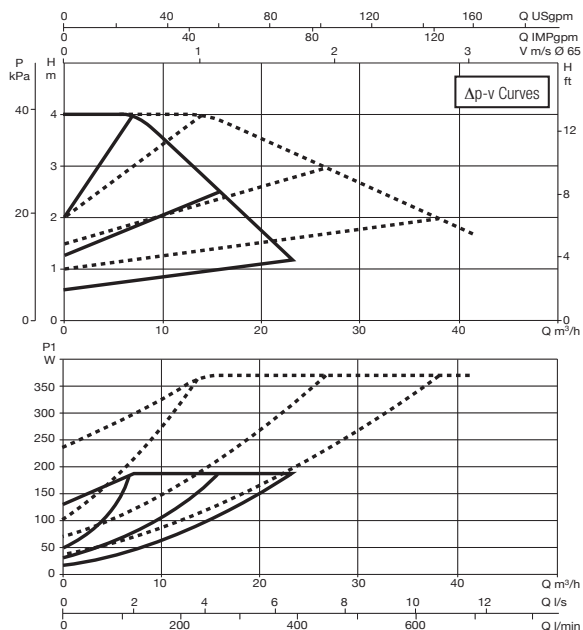

EVOPLUS D 60/340.65 M

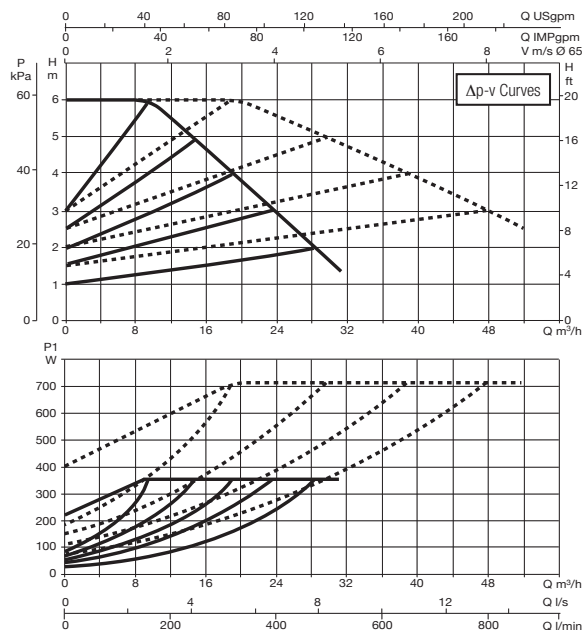

EVOPLUS D 40/340.65 M

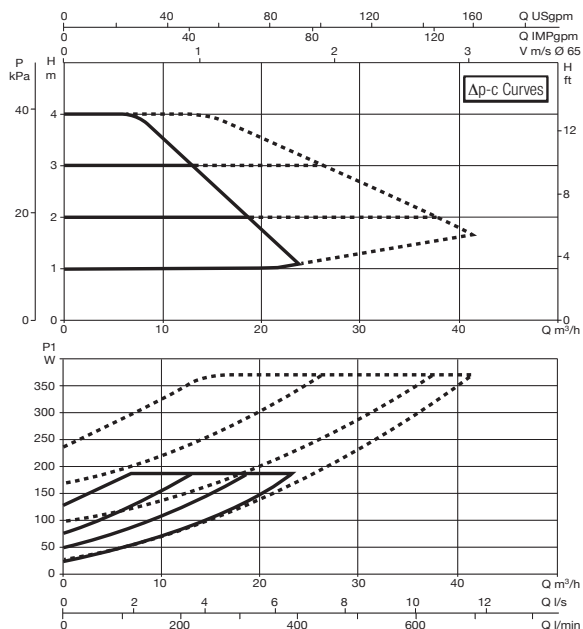

EVOPLUS D 60/340.65 M

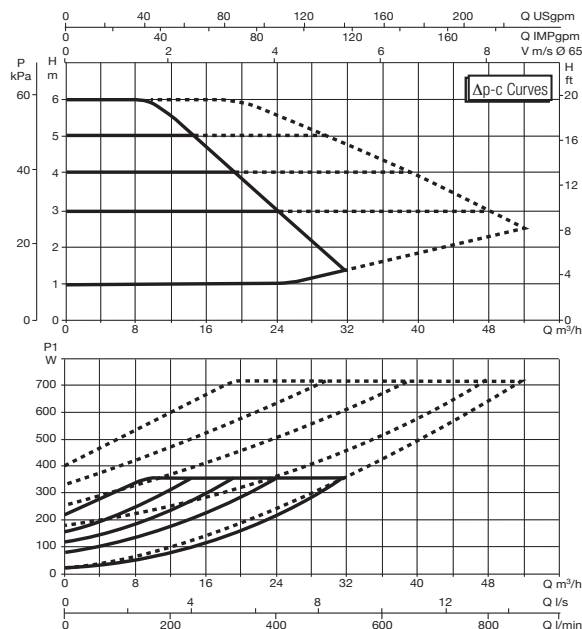

The curves are based on kinematic viscosity values = 1 mm²/s and density equal to 1000 kg/m³. Curve tolerance according to ISO 9906. Fixed speed curves available on the DNA.

MODEL	CENTRE DISTANCE mm	COUNTERFLANGES ON REQUEST	POWER INPUT 50/60 Hz	P1 MAX W	In A	EEI*	MINIMUM SUCTION PRESSURE			WEIGHT Kg
							t°	90°	100°	
EVOPLUS D 40/340.65 M	340	DN65 PN 10	220/240 V	190	1,1	EEI ≤ 0,21	m.c.w.	20	25	43,4
EVOPLUS D 60/340.65 M	340	DN65 PN 10	220/240 V	355	1,8	EEI ≤ 0,21	m.c.w.	20	25	43,4

* The parameter of reference for the more efficient circulators is EEI ≤ 0,20.

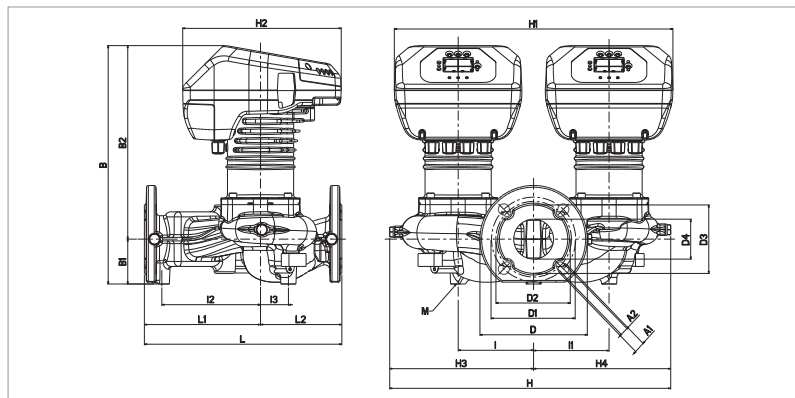

L	L1	L2	A1	A2	B	B1	B2	D	D1	D2	D3
340	200	140	19	14	411	77	334	185	145	130	118

D4	I	I1	I2	I3	M	H	H1	H2	H3	H4
69	130	130	170	48	M12	484	480	273	248	236

EVOPLUS - WET ROTOR ELECTRONIC CIRCULATORS

Pumped liquid temperature range: from -10 °C to +110°C - Maximum operating pressure: 16 bar (1600 kPa)

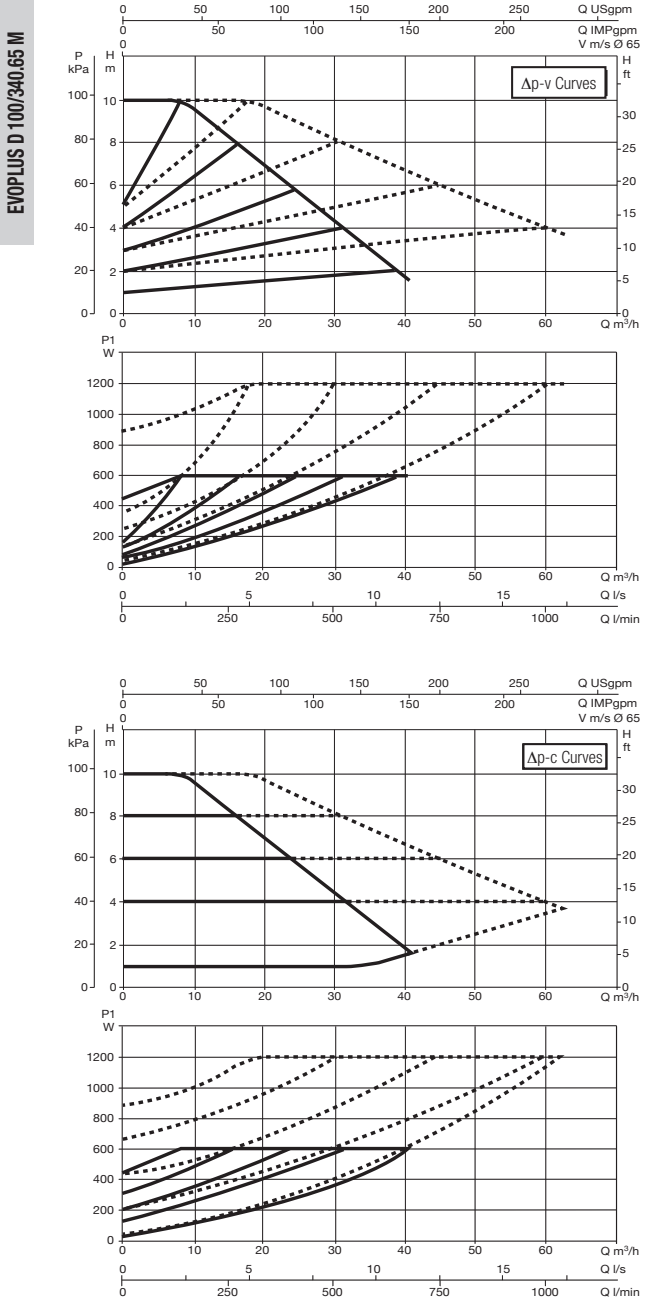
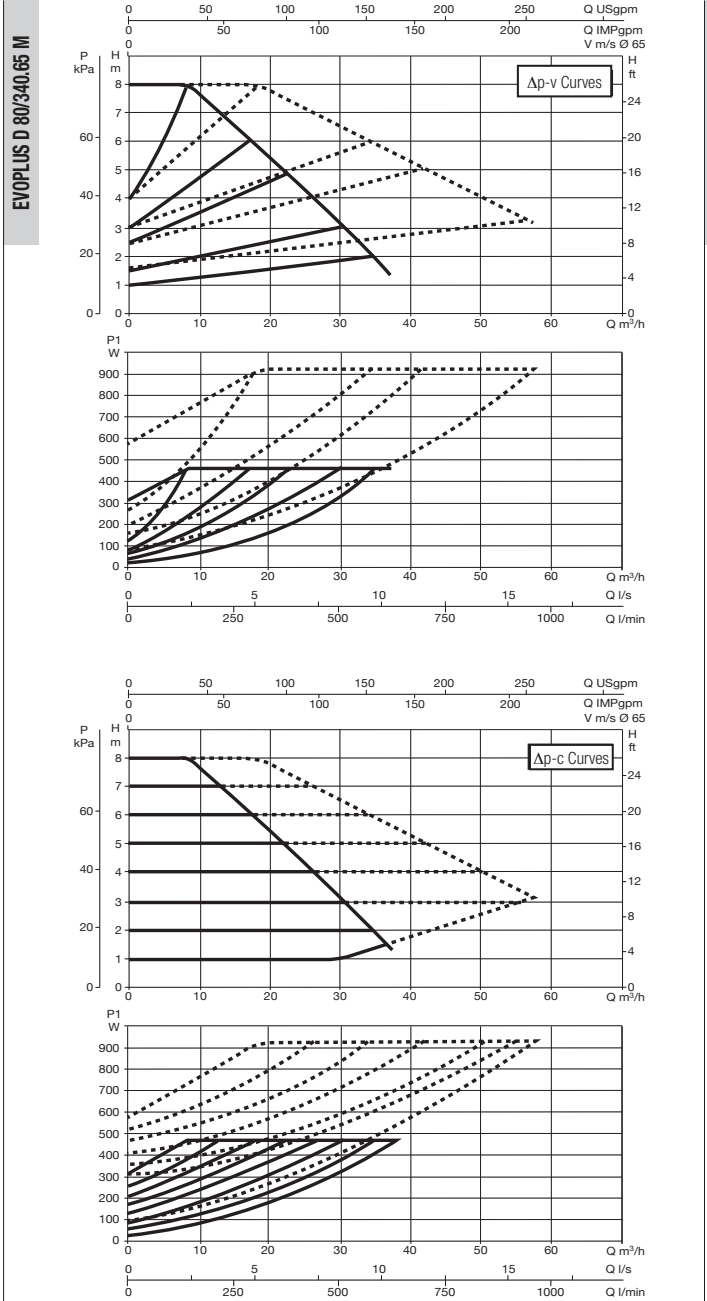

The curves are based on kinematic viscosity values = 1 mm²/s and density equal to 1000 kg/m³. Curve tolerance according to ISO 9906. Fixed speed curves available on the DNA.

MODEL	CENTRE DISTANCE mm	COUNTERFLANGES ON REQUEST	POWER INPUT 50/60 Hz	P1 MAX W	In A	EEI*	MINIMUM SUCTION PRESSURE			WEIGHT Kg
							t°	90°	100°	
EVOPLUS D 80/340.65 M	340	DN65 PN 10	220/240 V	465	2,2	EEI ≤ 0,21	m.c.w.	20	25	43,4
EVOPLUS D 100/340.65 M	340	DN65 PN 10	220/240 V	590	2,8	EEI ≤ 0,20	m.c.w.	20	25	44,8

* The parameter of reference for the more efficient circulators is EEI ≤ 0,20.

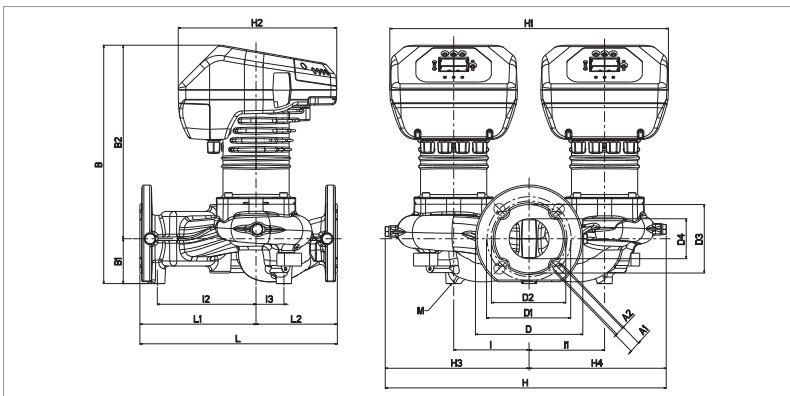

L	L1	L2	A1	A2	B	B1	B2	D	D1	D2	D3
340	200	140	19	14	411	77	334	185	145	130	118

D4	I	I1	I2	I3	M	H	H1	H2	H3	H4
69	130	130	170	48	M12	484	480	273	248	236

EVOPLUS - WET ROTOR ELECTRONIC CIRCULATORS

Pumped liquid temperature range: from -10 °C to +110 °C - Maximum operating pressure: 16 bar (1600 kPa)

EVOPLUS D 120/340.65 M

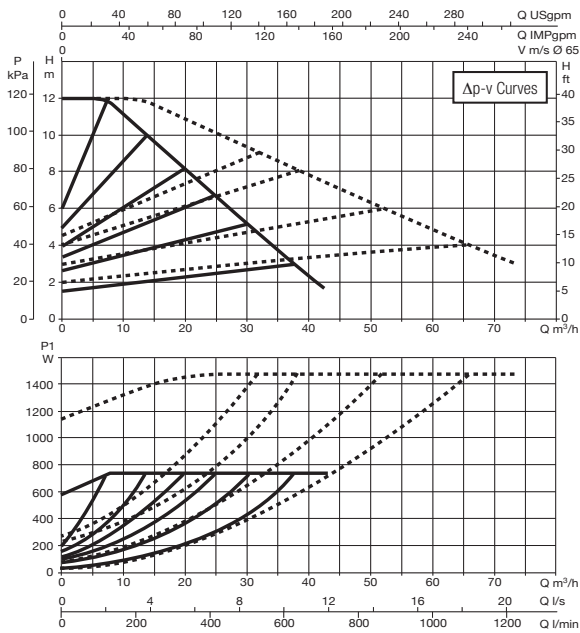

EVOPLUS D 150/340.65 M

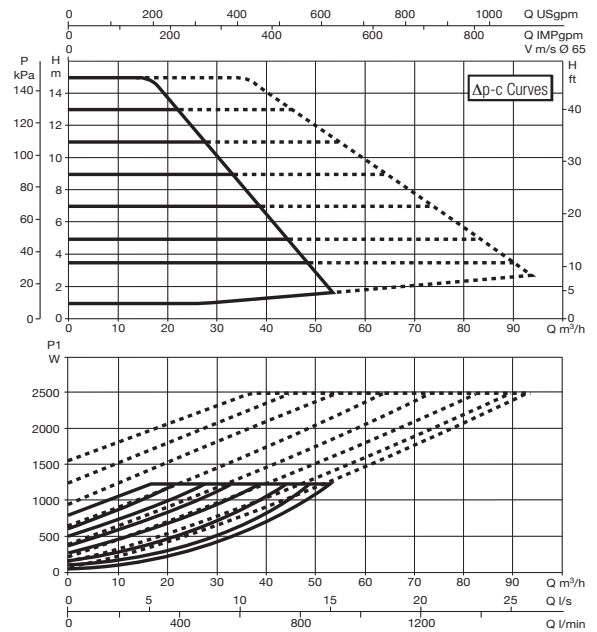
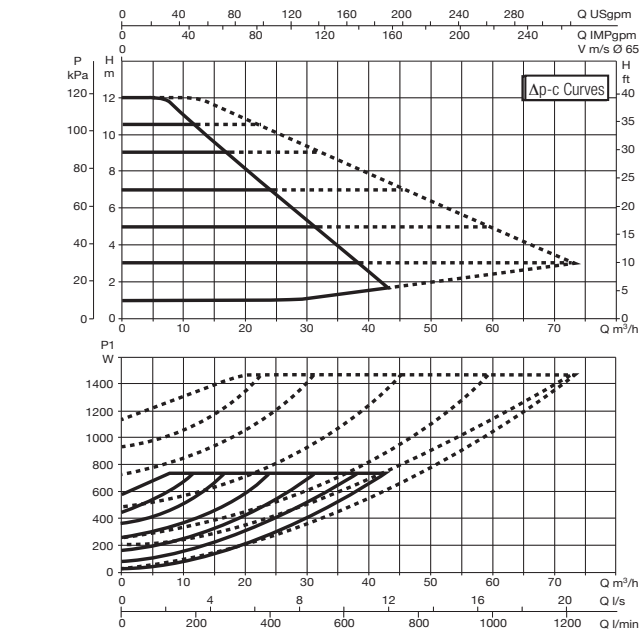
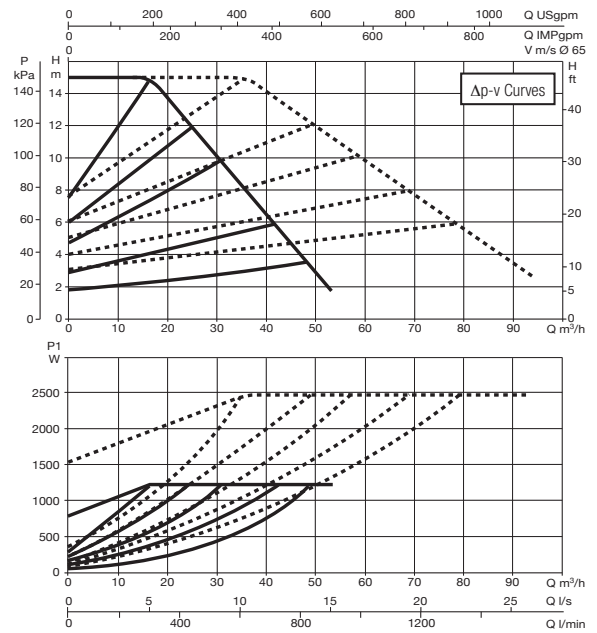

The curves are based on kinematic viscosity values = 1 mm²/s and density equal to 1000 kg/m³. Curve tolerance according to ISO 9906. Fixed speed curves available on the DNA.

MODEL	CENTRE DISTANCE mm	COUNTERFLANGES ON REQUEST	POWER INPUT 50/60 Hz	P1 MAX W	In A	EEI*	MINIMUM SUCTION PRESSURE			WEIGHT Kg
							t°	90°	100°	
EVOPLUS D 120/340.65 M	340	DN65 PN 10	220/240 V	730	3,45	EEI ≤ 0,20	m.c.w.	20	25	45
EVOPLUS D 150/340.65 M	340	DN65 PN 10	220/240 V	1210	5,5	EEI ≤ 0,20	m.c.w.	20	25	49,4

* The parameter of reference for the more efficient circulators is EEI ≤ 0,20.

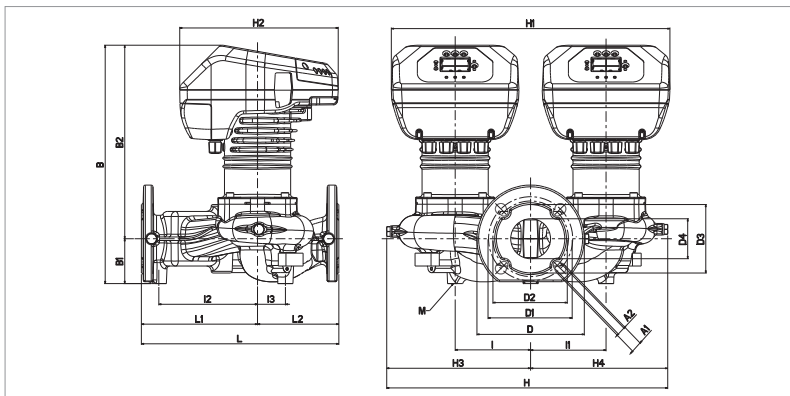

L	L1	L2	A1	A2	B	B1	B2	D	D1	D2	D3
340	200	140	19	14	411	77	334	185	145	130	118

D4	I	I1	I2	I3	M	H	H1	H2	H3	H4
69	130	130	170	48	M12	484	480	273	248	236

EVOPLUS - WET ROTOR ELECTRONIC CIRCULATORS

Pumped liquid temperature range: from -10 °C to +110 °C - Maximum operating pressure: 16 bar (1600 kPa)

EVOPLUS D 40/360.80 M

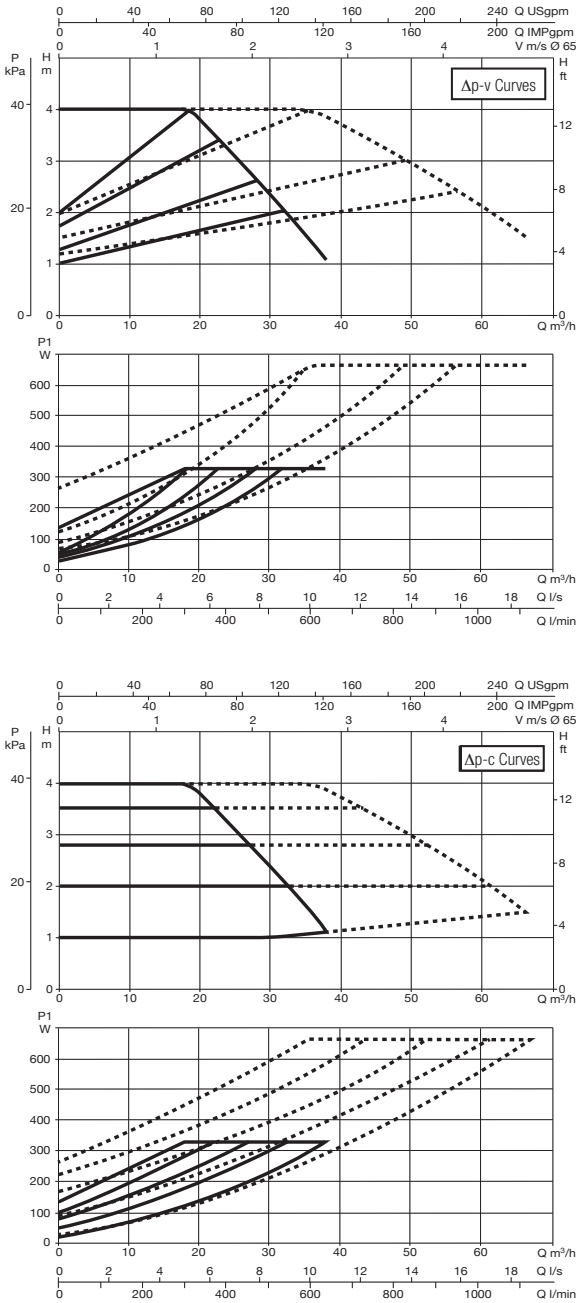

EVOPLUS D 60/360.80 M

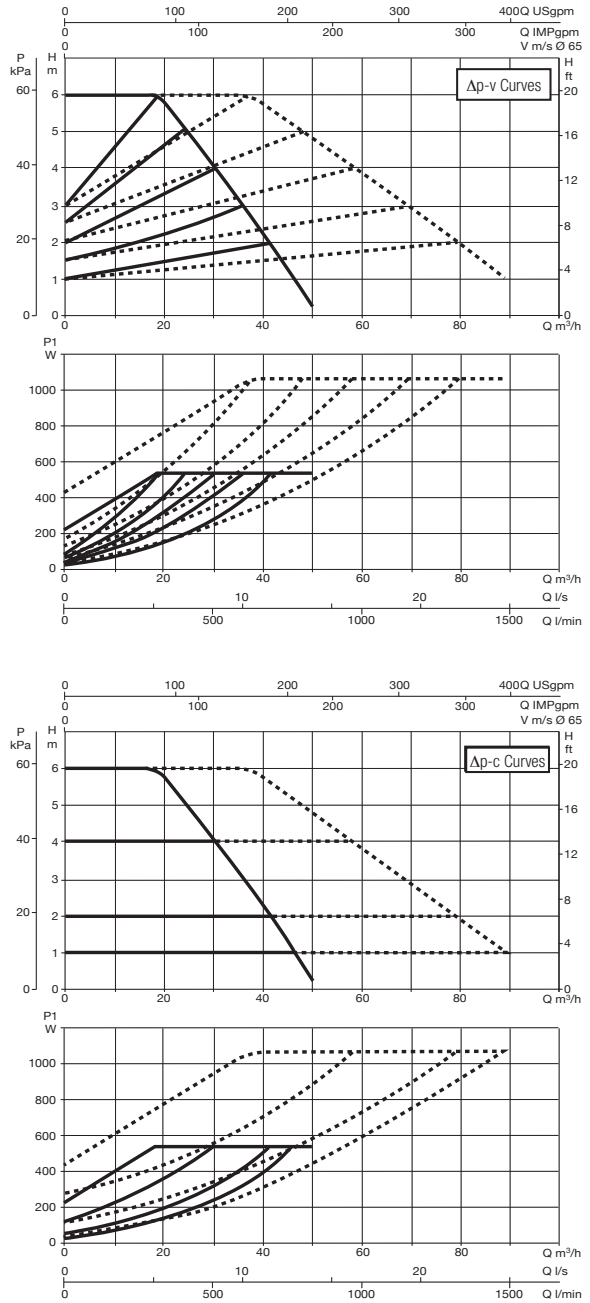

The curves are based on kinematic viscosity values = 1 mm²/s and density equal to 1000 kg/m³. Curve tolerance according to ISO 9906. Fixed speed curves available on the DNA.

MODEL	CENTRE DISTANCE mm	COUNTERFLANGES ON REQUEST	POWER INPUT 50/60 Hz	P1 MAX W	In A	EEI*	MINIMUM SUCTION PRESSURE			WEIGHT Kg
							t°	90°	100°	
EVOPLUS D 40/360.80 M	360	DN80 PN 10	220/240 V	330	1,65	EEI ≤ 0,20	m.c.w.	20	25	52
EVOPLUS D 60/360.80 M	360	DN80 PN 10	220/240 V	535	2,5	EEI ≤ 0,20	m.c.w.	20	25	52

* The parameter of reference for the more efficient circulators is EEI ≤ 0,20.

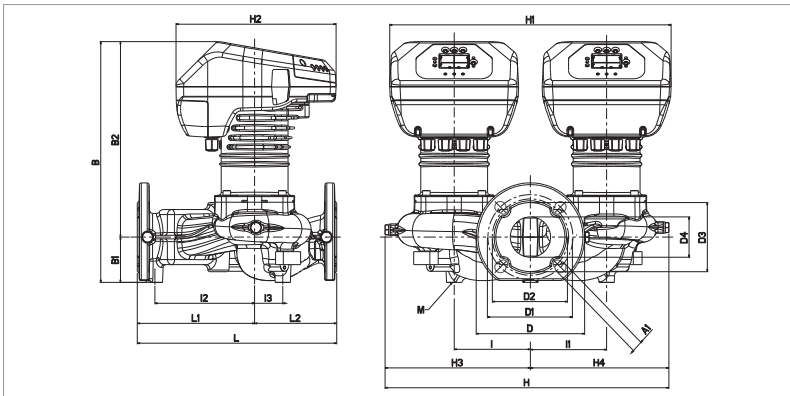

L	L1	L2	A1	B	B1	B2	D	D1	D3	D4
360	200	160	19	437	96	341	200	160	132	80

I	I1	I2	I3	M	H	H1	H2	H3	H4
130	130	160	58	M12	515	480	273	262	253

EVOPLUS - WET ROTOR ELECTRONIC CIRCULATORS

Pumped liquid temperature range: from -10 °C to +110 °C - Maximum operating pressure: 16 bar (1600 kPa)

EVOPLUS D 80/360.80 M

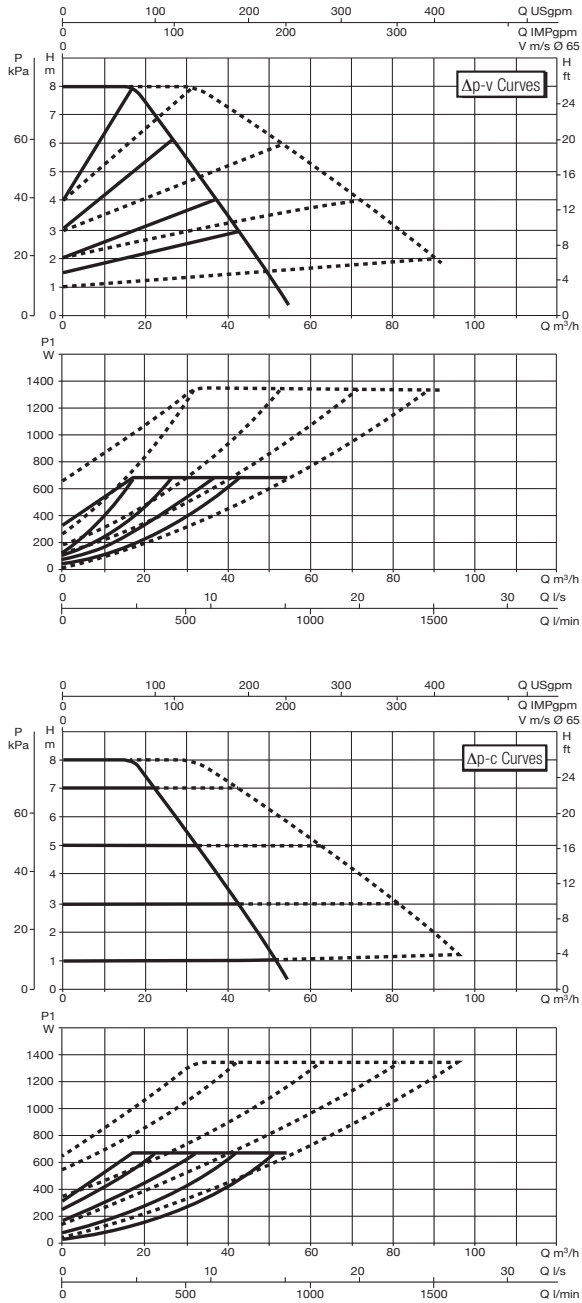

EVOPLUS D 100/360.80 M

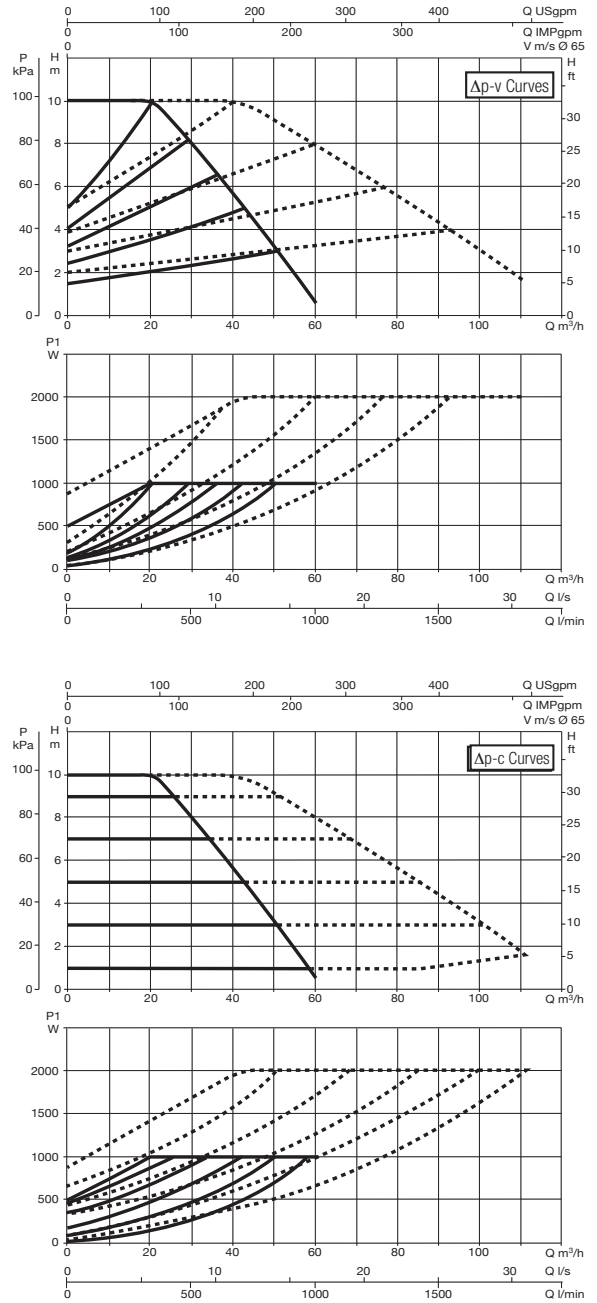

The curves are based on kinematic viscosity values = 1 mm²/s and density equal to 1000 kg/m³. Curve tolerance according to ISO 9906. Fixed speed curves available on the DNA.

MODEL	CENTRE DISTANCE mm	COUNTERFLANGES ON REQUEST	POWER INPUT 50/60 Hz	P1 MAX W	In A	EEI*	MINIMUM SUCTION PRESSURE			PESO Kg
							t°	90°	100°	
EVOPLUS D 80/360.80 M	360	DN80 PN 10	220/240 V	670	3	EEI ≤ 0,20	m.c.w.	20	25	57
EVOPLUS D 100/360.80 M	360	DN80 PN 10	220/240 V	1005	4,5	EEI ≤ 0,19	m.c.w.	20	25	56

* The parameter of reference for the more efficient circulators is EEI ≤ 0,20.

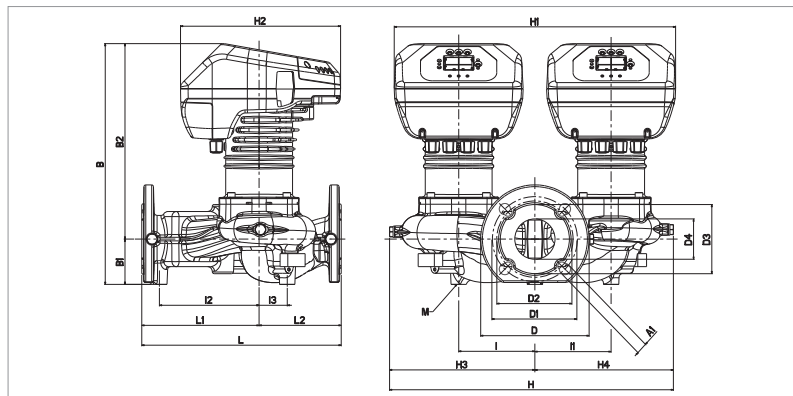

L	L1	L2	A1	B	B1	B2	D	D1	D3	D4
360	200	160	19	437	96	341	200	160	132	80

I	I1	I2	I3	M	H	H1	H2	H3	H4
130	130	160	58	M12	515	480	273	262	253

EVOPLUS - WET ROTOR ELECTRONIC CIRCULATORS

Pumped liquid temperature range: from -10 °C to +110 °C - Maximum operating pressure: 16 bar (1600 kPa)

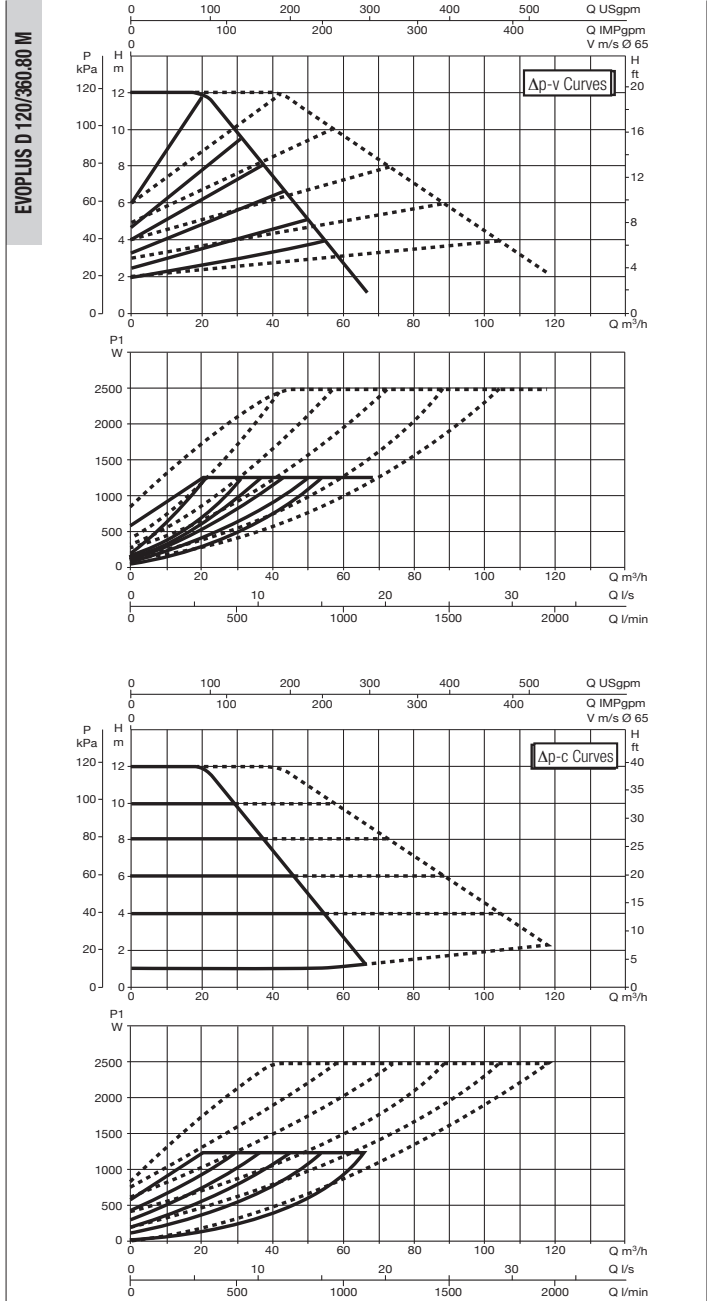

The curves are based on kinematic viscosity values = 1 mm²/s and density equal to 1000 kg/m³. Curve tolerance according to ISO 9906. Fixed speed curves available on the DNA.

MODEL	CENTRE DISTANCE mm	COUNTERFLANGES ON REQUEST	POWER INPUT 50/60 Hz	P1 MAX W	In A	EEI*	MINIMUM SUCTION PRESSURE			WEIGHT Kg
							t°	90°	100°	
EVOPLUS D 120/360.80 M	360	DN80 PN 10	220/240 V	1235	5,5	EEI ≤ 0,19	m.c.w.	20	25	56,4

* The parameter of reference for the more efficient circulators is EEI ≤ 0,20.

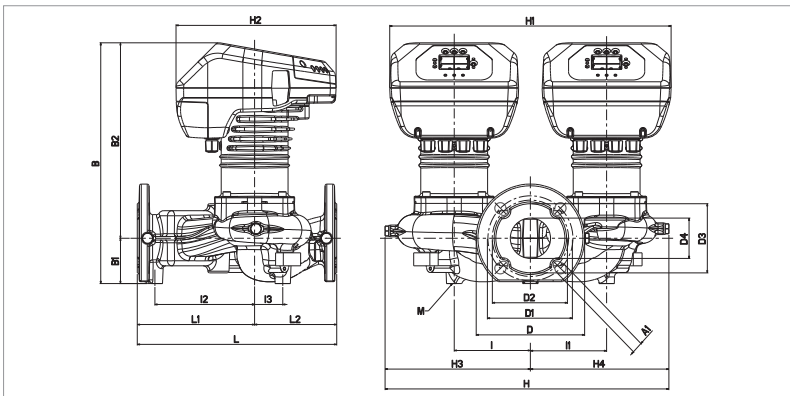

L	L1	L2	A1	B	B1	B2	D	D1	D3	D4
360	200	160	19	437	96	341	200	160	132	80

I	I1	I2	I3	M	H	H1	H2	H3	H4
130	130	160	58	M12	515	480	273	262	253

EVOPLUS - WET ROTOR ELECTRONIC CIRCULATORS

Pumped liquid temperature range: from -10 °C to +110 °C - Maximum operating pressure: 16 bar (1600 kPa)

EVOPLUS D 40/450,100 M

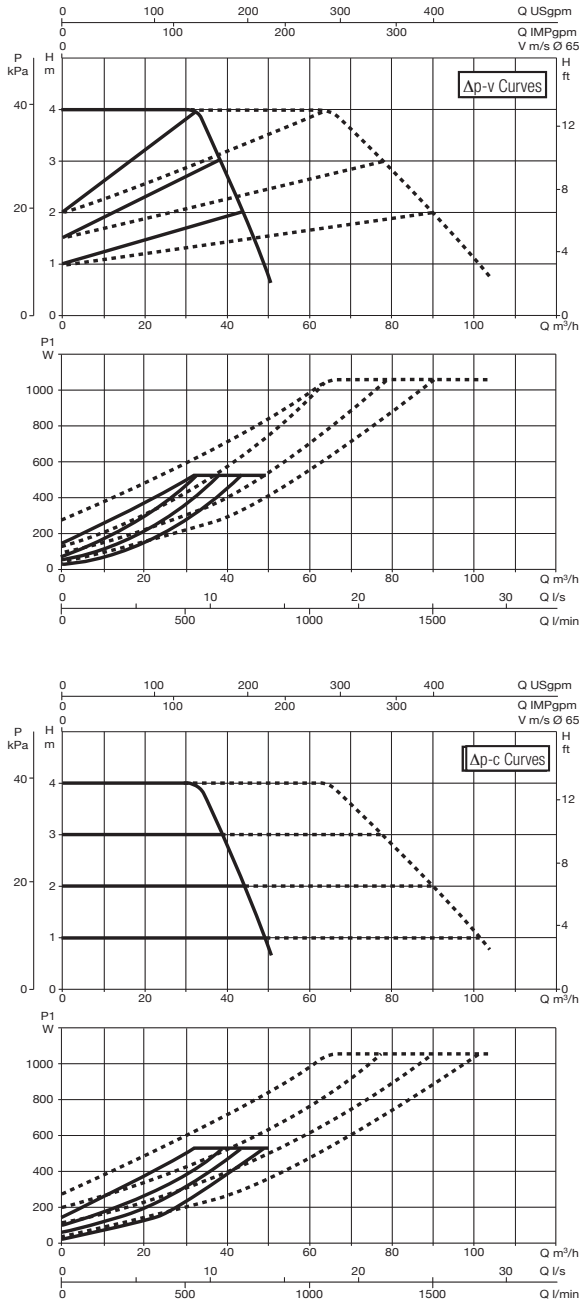

EVOPLUS D 60/450,100 M

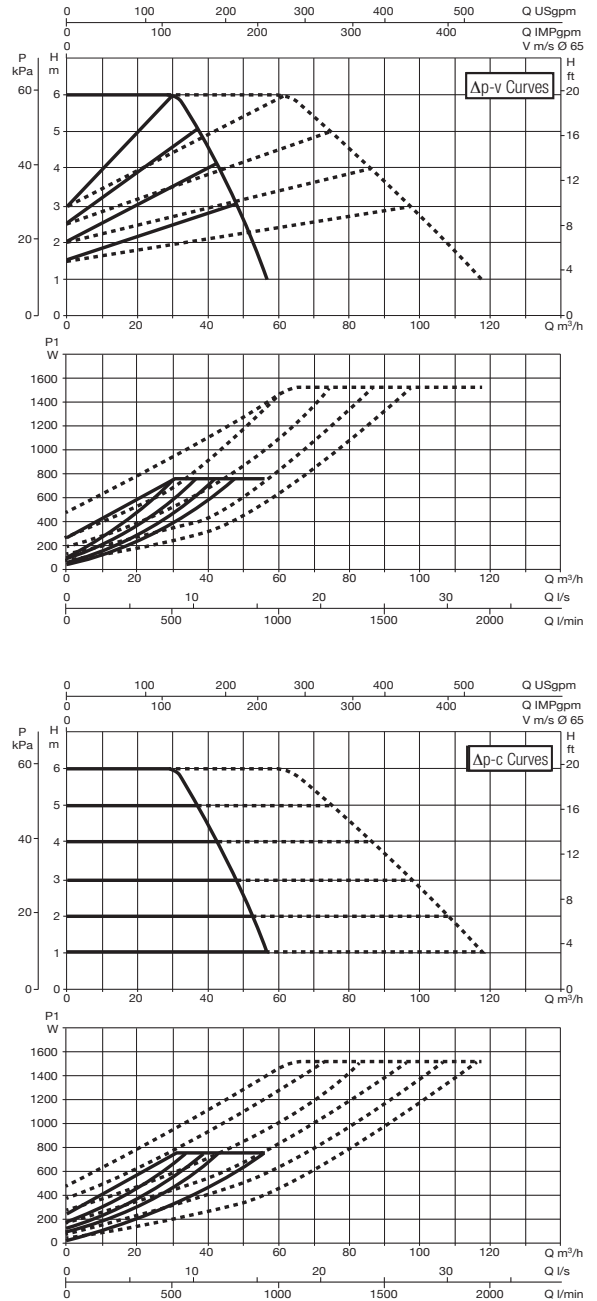

WET ROTOR ELECTRONIC CIRCULATORS

The curves are based on kinematic viscosity values = 1 mm²/s and density equal to 1000 kg/m³. Curve tolerance according to ISO 9906. Fixed speed curves available on the DNA.

MODEL	CENTRE DISTANCE mm	COUNTERFLANGES ON REQUEST	POWER INPUT 50/60 Hz	P1 MAX W	In A	EEI*	MINIMUM SUCTION PRESSURE			WEIGHT Kg
							t°	90°	100°	
EVOPLUS D 40/450.100 M	450	DN100 PN 10	220/240 V	530	2,5	EEI ≤ 0,19	m.c.w.	20	25	67,8
EVOPLUS D 60/450.100 M	450	DN100 PN 10	220/240 V	760	3,5	EEI ≤ 0,19	m.c.w.	20	25	67,8

* The parameter of reference for the more efficient circulators is EEI ≤ 0,20.

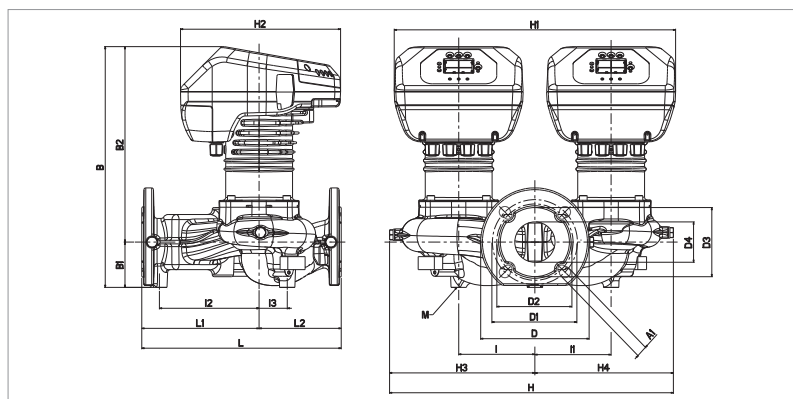

L	L1	L2	A1	B	B1	B2	D	D1	D3	D4
450	260	190	19	456	103	353	220	180	156	105

I	I1	I2	I3	M	H	H1	H2	H3	H4
135	135	200	43	12	517	490	273	265	252

EVOPLUS - WET ROTOR ELECTRONIC CIRCULATORS

Pumped liquid temperature range: from -10 °C to +110 °C - Maximum operating pressure: 16 bar (1600 kPa)

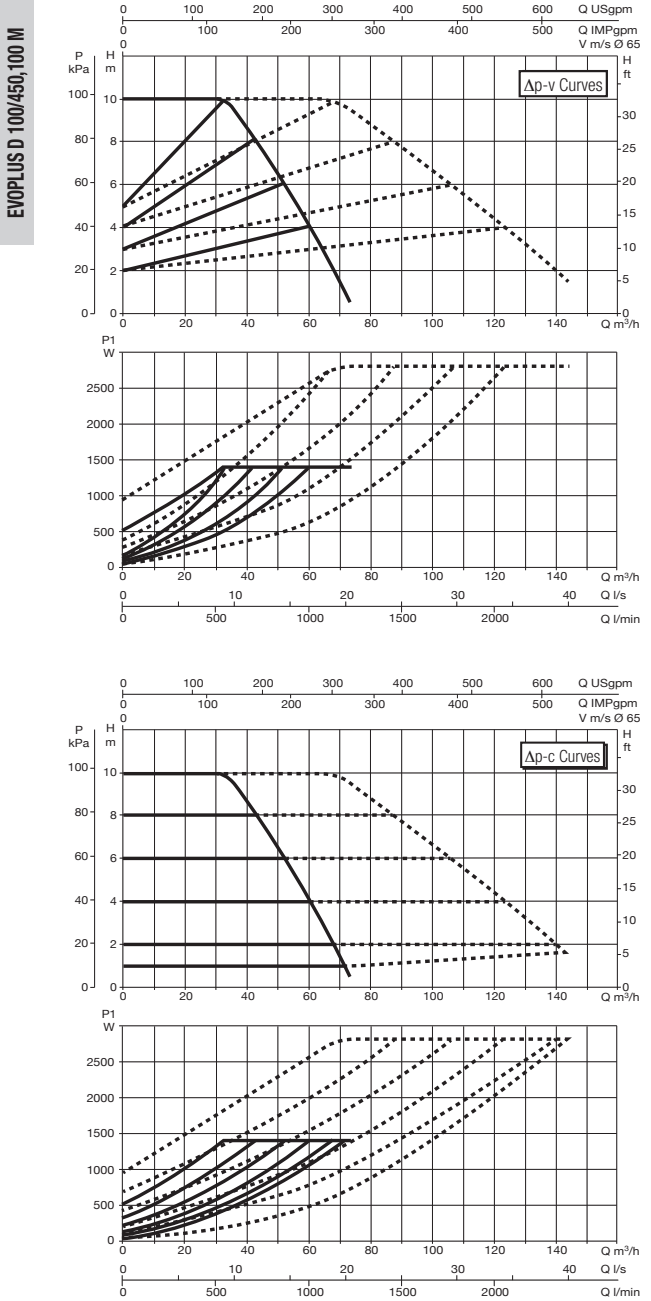
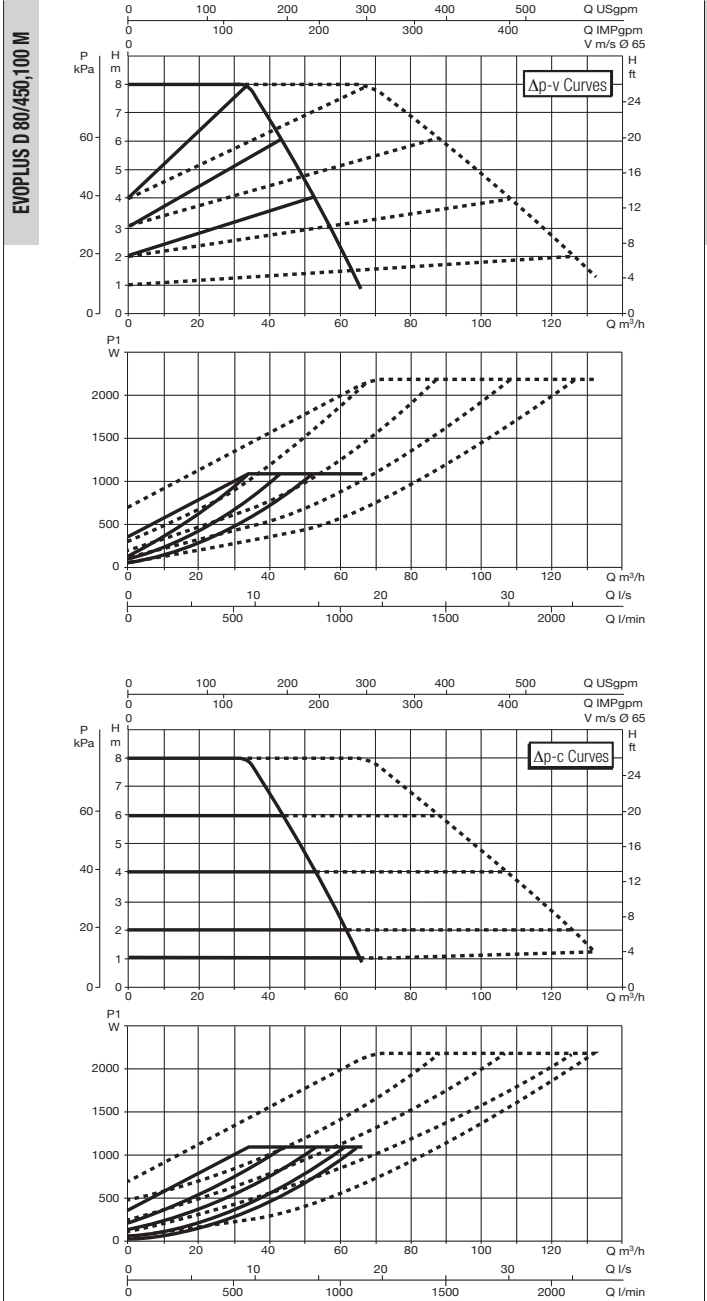

The curves are based on kinematic viscosity values = 1 mm²/s and density equal to 1000 kg/m³. Curve tolerance according to ISO 9906. Fixed speed curves available on the DNA.

MODEL	CENTRE DISTANCE mm	COUNTERFLANGES ON REQUEST	POWER INPUT 50/60 Hz	P1 MAX W	In A	EEI*	MINIMUM SUCTION PRESSURE			WEIGHT Kg
							t°	90°	100°	
EVOPLUS D 80/450.100 M	450	DN100 PN 10	220/240 V	1080	4,8	EEI ≤ 0,20	m.c.w.	20	25	68
EVOPLUS D 100/450.100 M	450	DN100 PN 10	220/240 V	1380	6	EEI ≤ 0,20	m.c.w.	20	25	68

* The parameter of reference for the more efficient circulators is EEI ≤ 0,20.

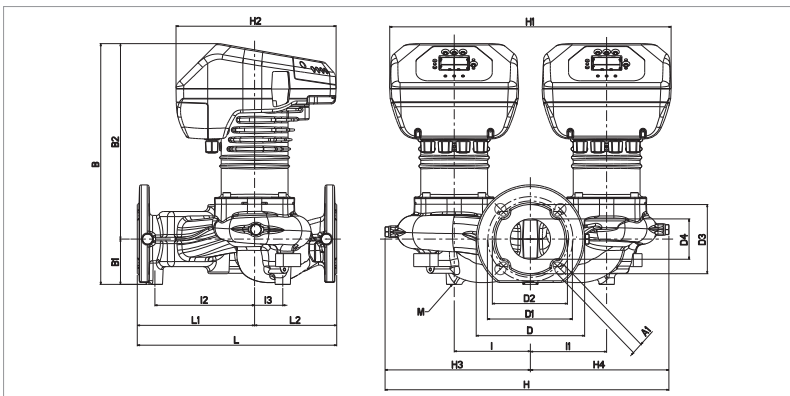

L	L1	L2	A1	B	B1	B2	D	D1	D3	D4
450	260	190	19	456	103	353	220	180	156	105

I	I1	I2	I3	M	H	H1	H2	H3	H4
135	135	200	43	12	517	490	273	265	252

EVOPLUS – WET ROTOR ELECTRONIC CIRCULATORS

Pumped liquid temperature range: from -10 °C to +110 °C - Maximum operating pressure: 16 bar (1600 kPa)

EVOPLUS D 120/450,100 M

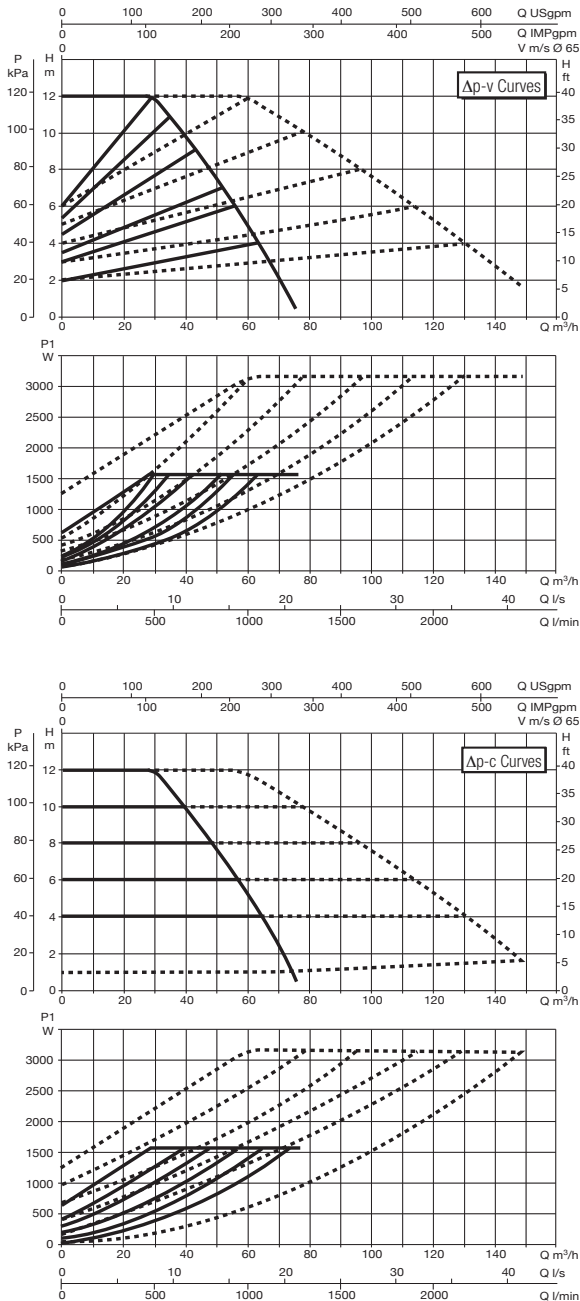

The curves are based on kinematic viscosity values = 1 mm²/s and density equal to 1000 kg/m³. Curve tolerance according to ISO 9906. Fixed speed curves available on the DNA.

MODEL	CENTRE DISTANCE mm	COUNTERFLANGES ON REQUEST	POWER INPUT 50/60 Hz	P1 MAX W	In A	EEI*	MINIMUM SUCTION PRESSURE			WEIGHT Kg
							t°	90°	100°	
EVOPLUS D 120/450.100 M	450	DN100 PN 10	220/240 V	1560	7	EEI ≤ 0,20	m.c.w.	20	25	67,8

* The parameter of reference for the more efficient circulators is EEI ≤ 0,20.

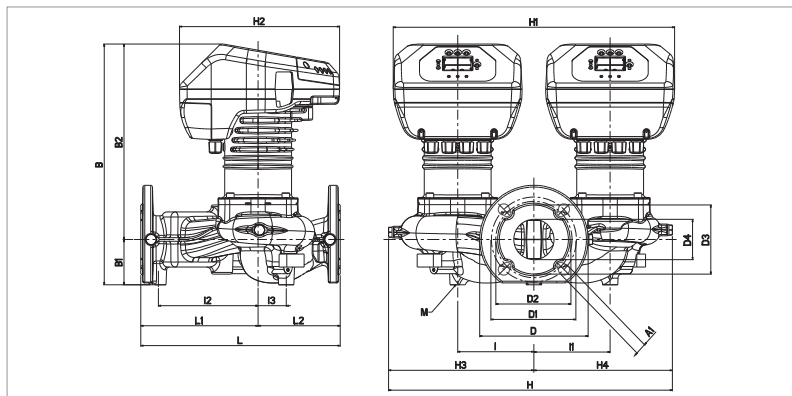

L	L1	L2	A1	B	B1	B2	D	D1	D3	D4
450	260	190	19	456	103	353	220	180	156	105

I	I1	I2	I3	M	H	H1	H2	H3	H4
135	135	200	43	12	517	490	273	265	252

EVOPLUS SAN - WET ROTOR ELECTRONIC CIRCULATORS

Pumped liquid temperature range: from -10 °C to +110 °C - Maximum operating pressure: 16 bar (1600 kPa)

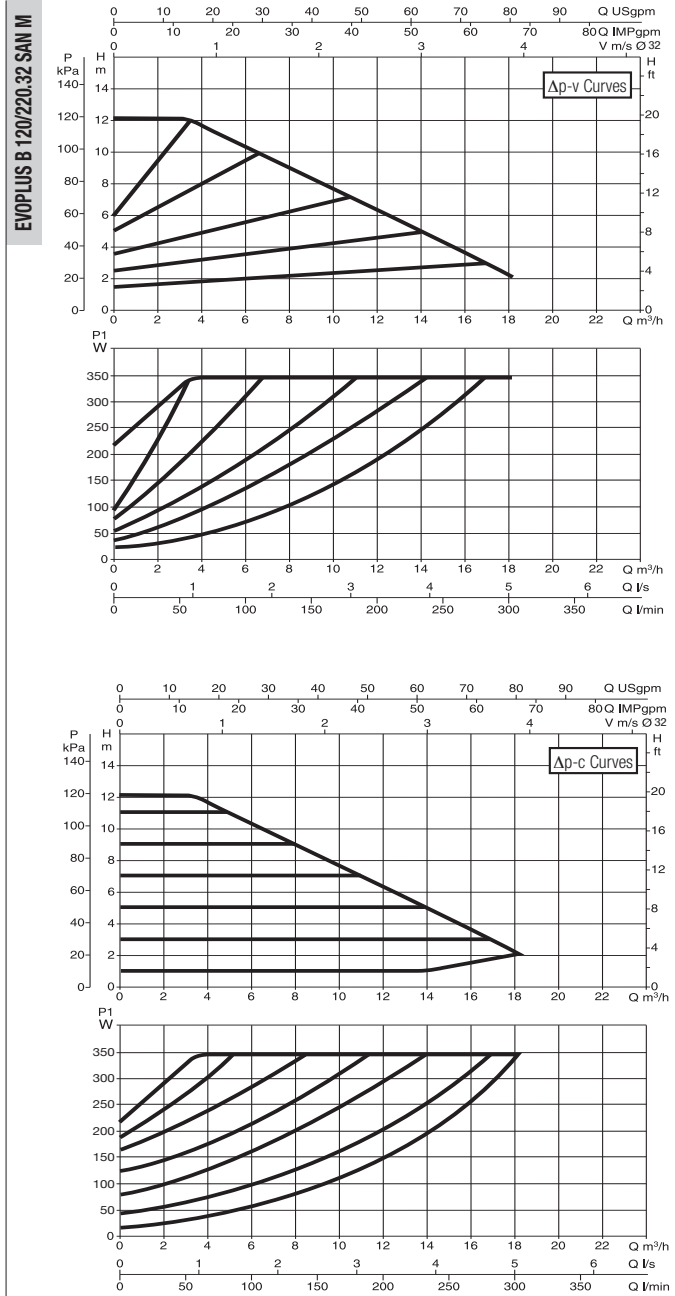

The curves are based on kinematic viscosity values = 1 mm²/s and density equal to 1000 kg/m³. Curve tolerance according to ISO 9906. Fixed speed curves available on the DNA.

MODEL	CENTRE DISTANCE mm	COUNTERFLANGES ON REQUEST	POWER INPUT 50/60 Hz	P1 MAX W	In A	MINIMUM SUCTION PRESSURE			WEIGHT Kg
						t°	90°	100°	
EVOPLUS B 120/220.32 SAN M	220	DN 32 PN 6	220/240 V	340	1,7	m.c.w.	20	25	24

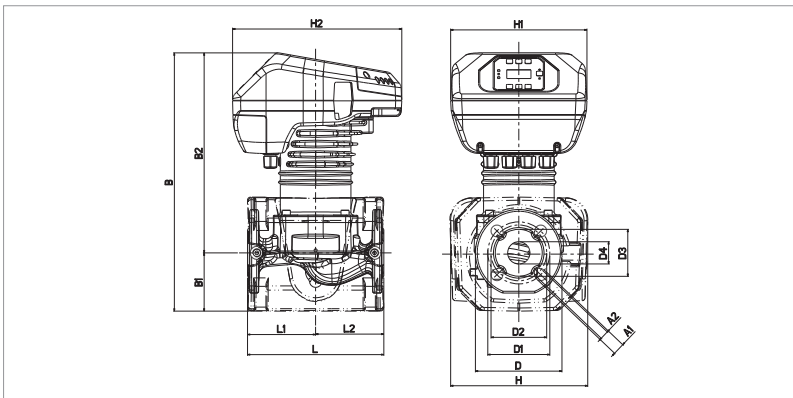

L	L1	L2	A1	A2	B	B1	B2
220	110	110	19	14	417	94	323

D	D1	D2	D3	D4	H	H1	H2
140	100	90	76	36	222	220	273

EVOPLUS SAN - WET ROTOR ELECTRONIC CIRCULATORS

Pumped liquid temperature range: from -10 °C to +110 °C - Maximum operating pressure: 16 bar (1600 kPa)

EVOPLUS B 120/250.40 SAN M

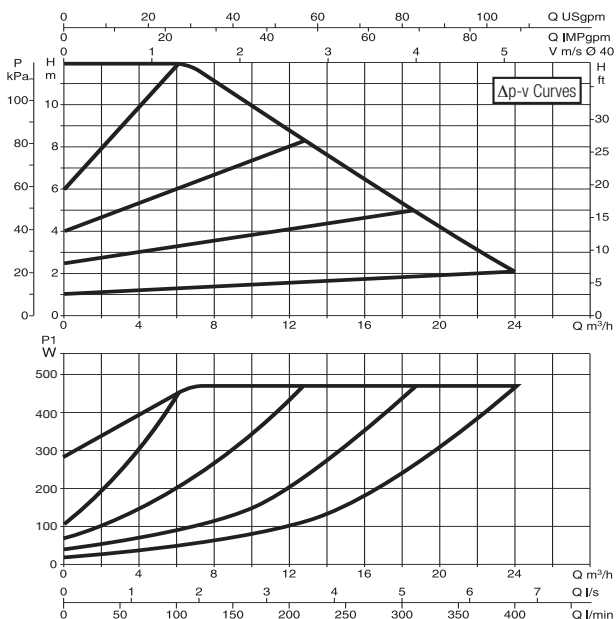

EVOPLUS B 150/250.40 SAN M

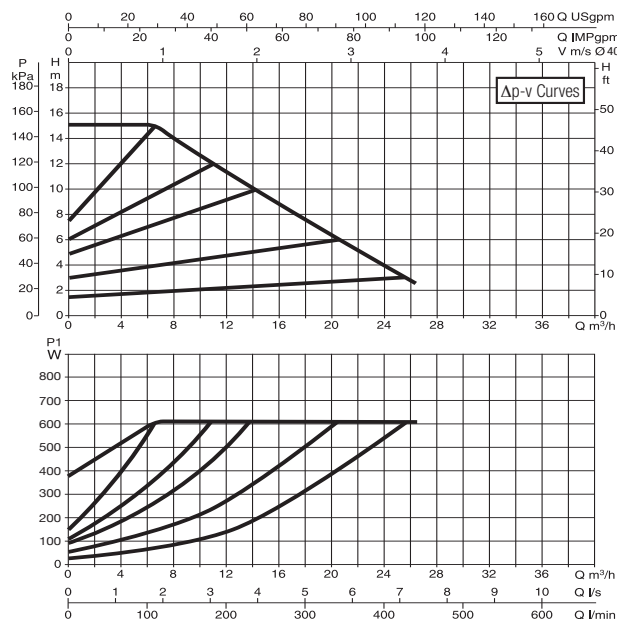

WET ROTOR ELECTRONIC CIRCULATORS

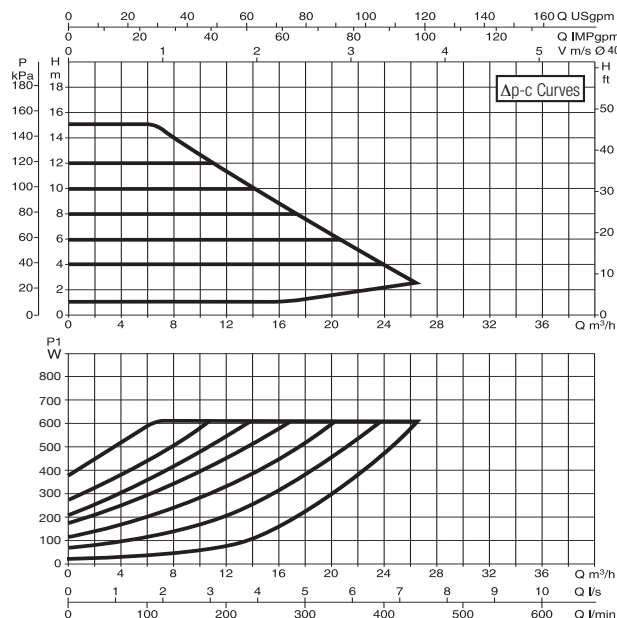
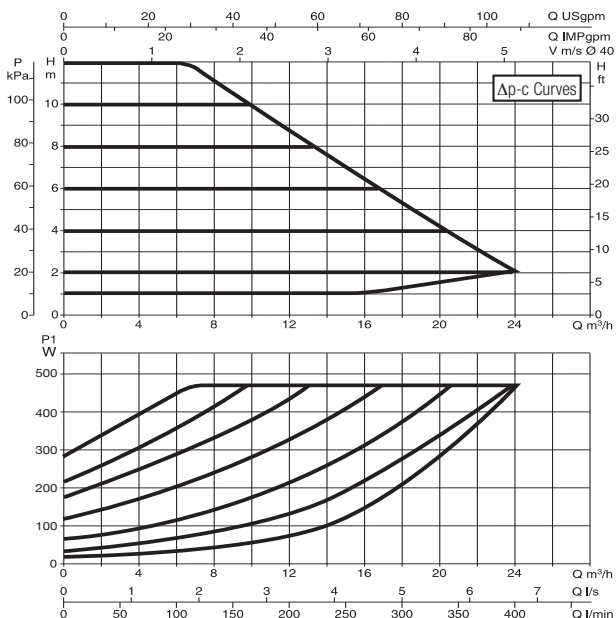

The curves are based on kinematic viscosity values = 1 mm²/s and density equal to 1000 kg/m³. Curve tolerance according to ISO 9906. Fixed speed curves available on the DNA.

MODEL	CENTRE DISTANCE mm	COUNTERFLANGES ON REQUEST	POWER INPUT 50/60 Hz	P1 MAX W	In A	MINIMUM SUCTION PRESSURE			WEIGHT Kg
						t°	90°	100°	
EVOPLUS B 120/250.40 SAN M	250	DN 40 PN 10	220/240 V	465	2,2	m.c.w.	20	25	22
EVOPLUS B 150/250.40 SAN M	250	DN 40 PN 10	220/240 V	610	2,9	m.c.w.	20	25	20

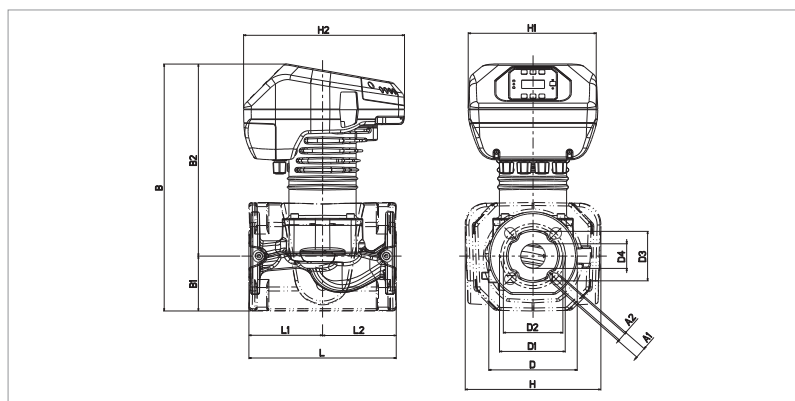

L	L1	L2	A1	A2	B	B1	B2
250	125	125	19	14	419	93	326

D	D1	D2	D3	D4	H	H1	H2
150	110	100	84	42	230	220	273

EVOPLUS SAN - WET ROTOR ELECTRONIC CIRCULATORS

Pumped liquid temperature range: from -10 °C to +110 °C - Maximum operating pressure: 16 bar (1600 kPa)

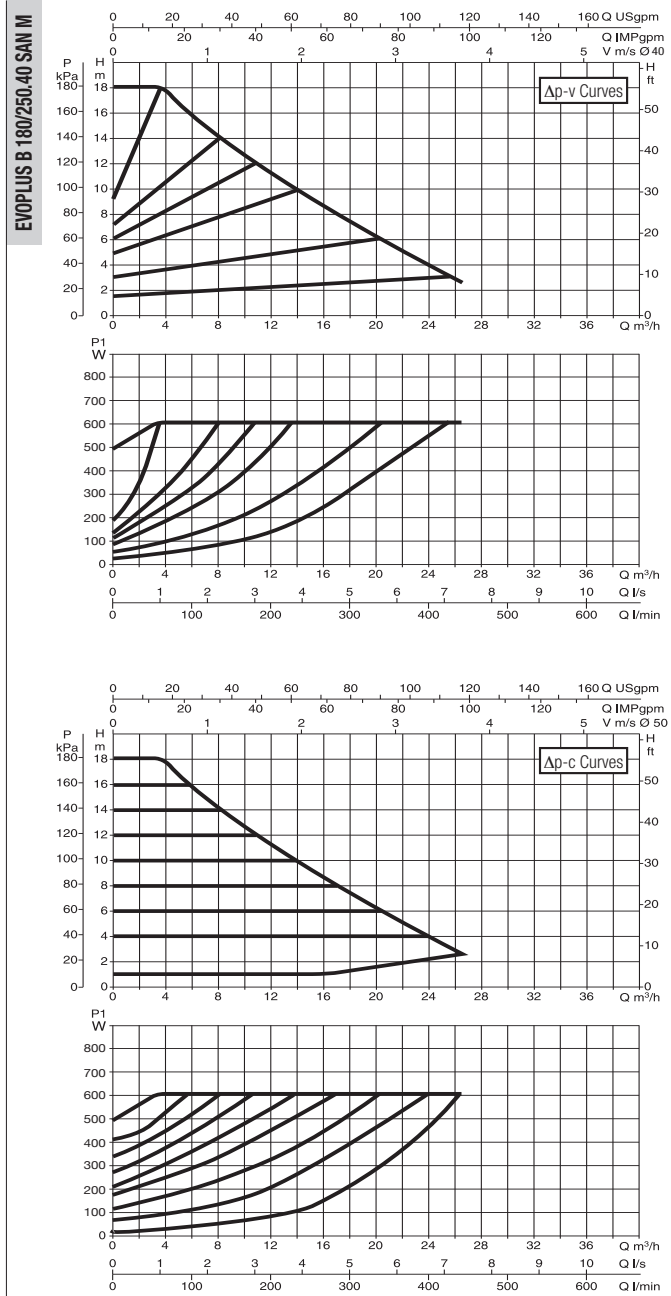

The curves are based on kinematic viscosity values = 1 mm²/s and density equal to 1000 kg/m³. Curve tolerance according to ISO 9906. Fixed speed curves available on the DNA.

MODEL	CENTRE DISTANCE mm	COUNTERFLANGES ON REQUEST	POWER INPUT 50/60 Hz	P1 MAX W	In A	MINIMUM SUCTION PRESSURE			WEIGHT Kg
						t°	90°	100°	
EVOPLUS B 180/250.40 SAN M	250	DN 40 PN 10	220/240 V	610	2,9	m.c.w.	20	25	20

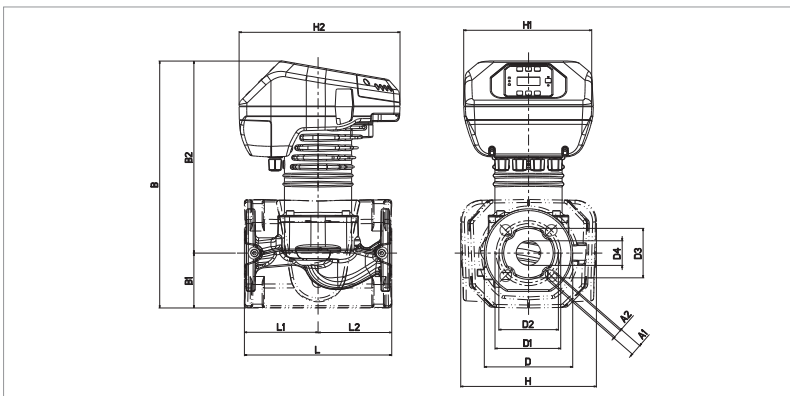

L	L1	L2	A1	A2	B	B1	B2
250	125	125	19	14	419	93	326

D	D1	D2	D3	D4	H	H1	H2
150	110	100	84	42	230	220	273

EVOPLUS SAN - WET ROTOR ELECTRONIC CIRCULATORS

Pumped liquid temperature range: from -10 °C to +110 °C - Maximum operating pressure: 16 bar (1600 kPa)

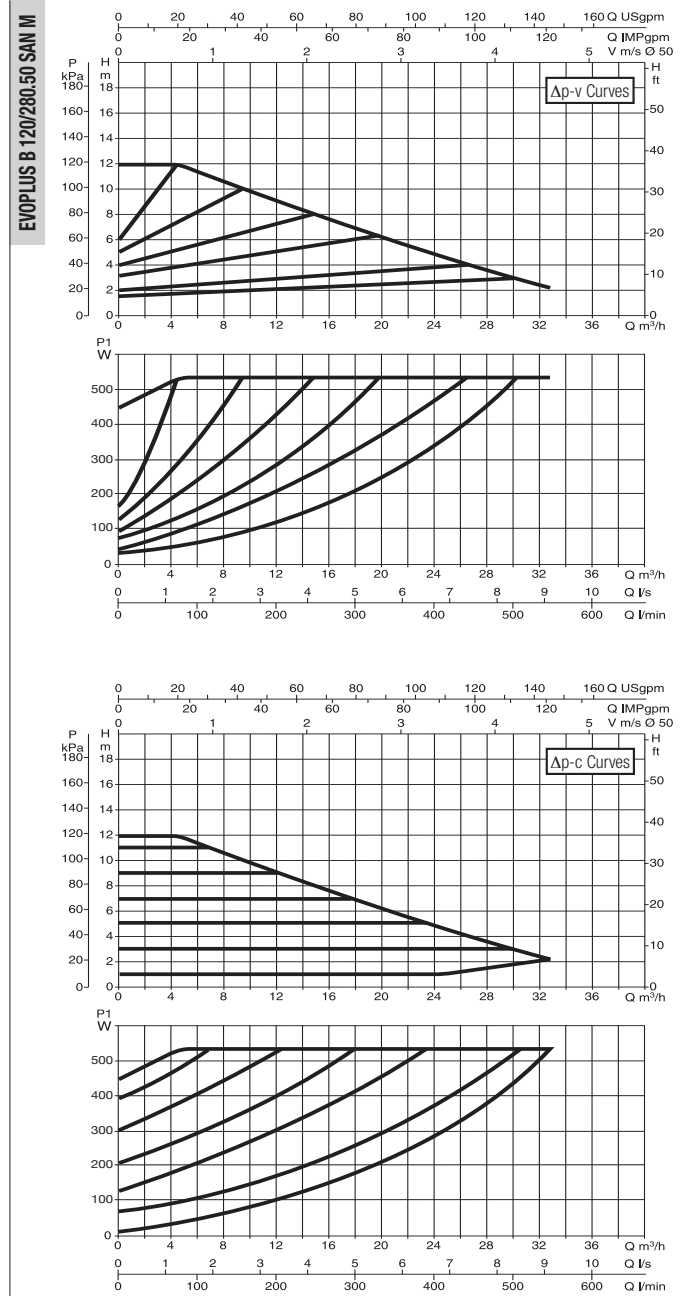
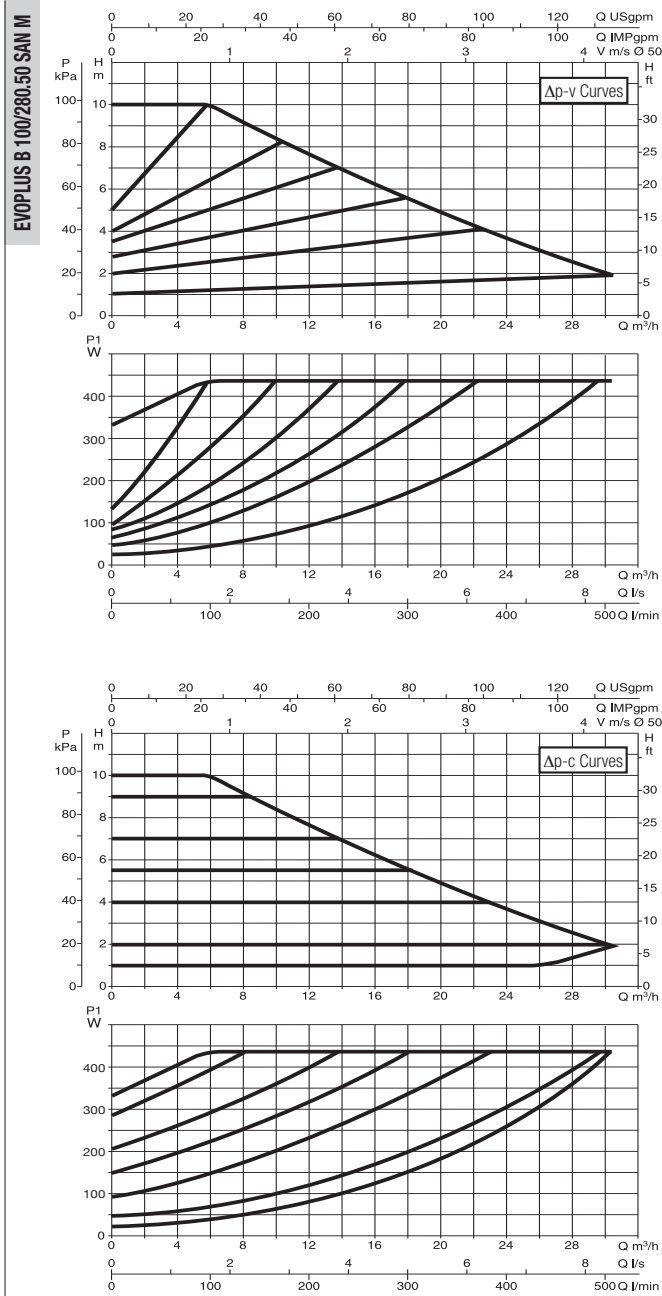

The curves are based on kinematic viscosity values = 1 mm²/s and density equal to 1000 kg/m³. Curve tolerance according to ISO 9906. Fixed speed curves available on the DNA.

MODEL	CENTRE DISTANCE mm	COUNTERFLANGES ON REQUEST	POWER INPUT 50/60 Hz	P1 MAX W	In A	MINIMUM SUCTION PRESSURE			WEIGHT Kg
						t°	90°	100°	
EVOPLUS B 100/280.50 SAN M	280	DN 50 PN 10	220/240 V	430	2,1	m.c.w.	20	25	22
EVOPLUS B 120/280.50 SAN M	280	DN 50 PN 10	220/240 V	530	2,5	m.c.w.	20	25	21,8

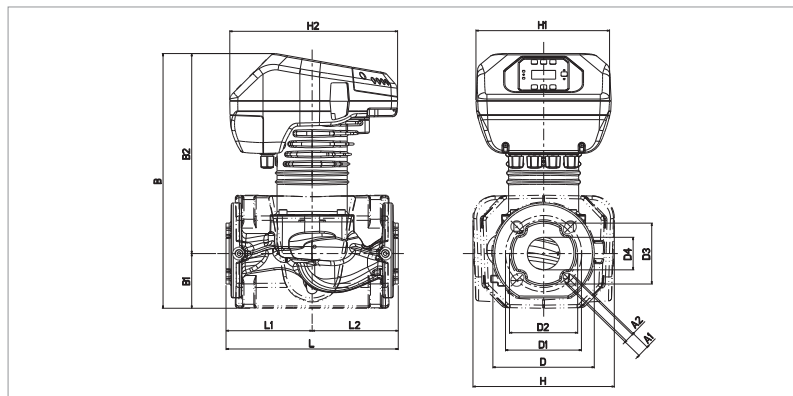

L	L1	L2	A1	A2	B	B1	B2
280	140	140	19	14	413	87	325

D	D1	D2	D3	D4	H	H1	H2
165	125	110	99	53	230	220	273

EVOPLUS SAN - WET ROTOR ELECTRONIC CIRCULATORS

Pumped liquid temperature range: from -10 °C to +110 °C - Maximum operating pressure: 16 bar (1600 kPa)

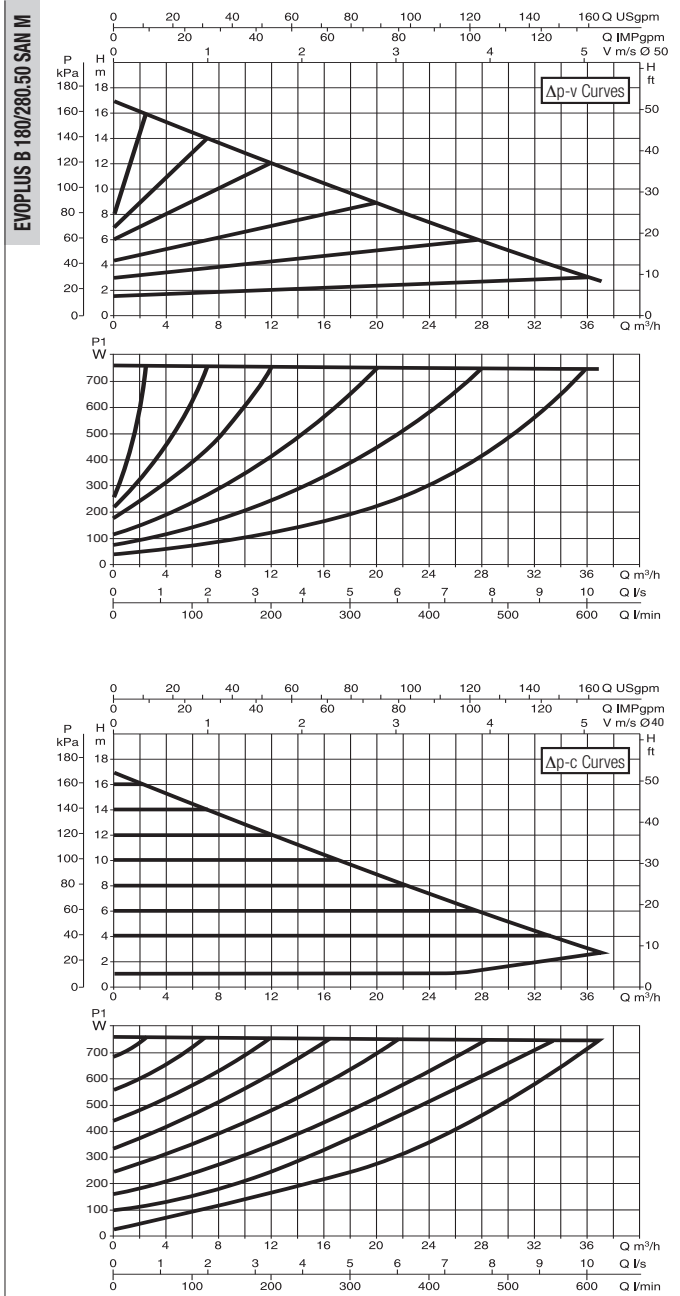
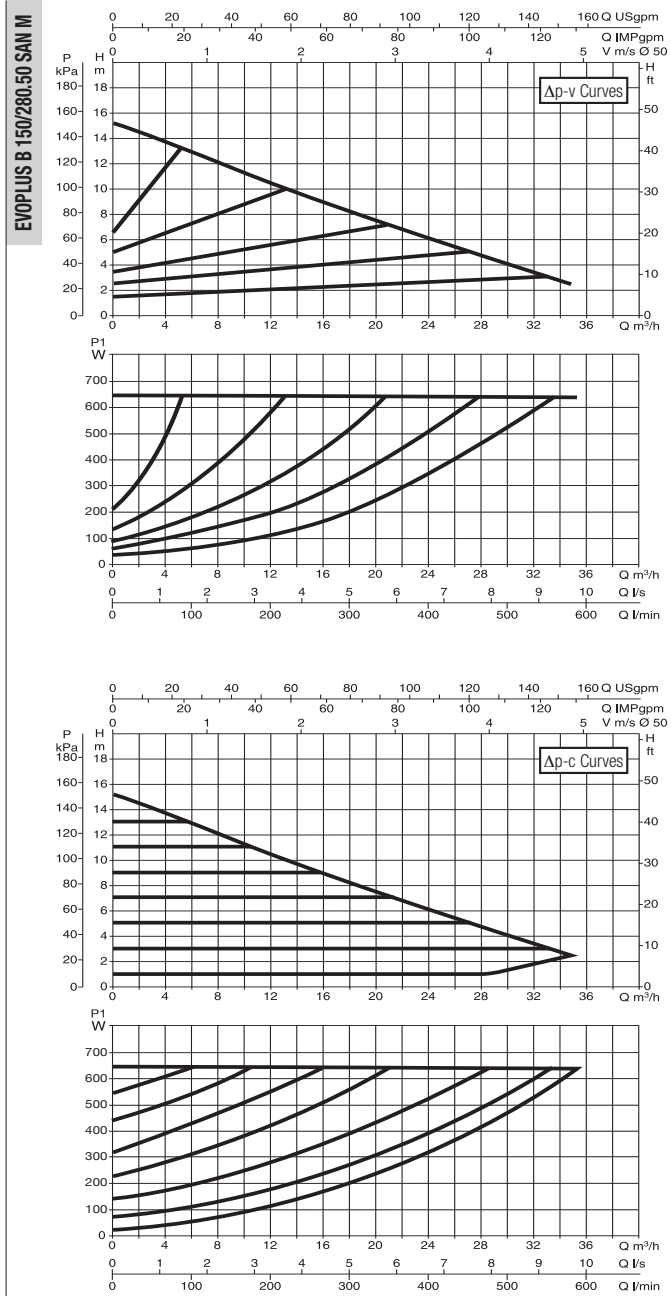

The curves are based on kinematic viscosity values = 1 mm²/s and density equal to 1000 kg/m³. Curve tolerance according to ISO 9906. Fixed speed curves available on the DNA.

MODEL	CENTRE DISTANCE mm	COUNTERFLANGES ON REQUEST	POWER INPUT 50/60 Hz	P1 MAX W	In A	MINIMUM SUCTION PRESSURE			WEIGHT Kg
						t°	90°	100°	
EVOPLUS B 150/280.50 SAN M	280	DN 50 PN 10	220/240 V	640	3	m.c.w.	20	25	22,8
EVOPLUS B 180/280.50 SAN M	280	DN 50 PN 10	220/240 V	750	3,45	m.c.w.	20	25	22,8

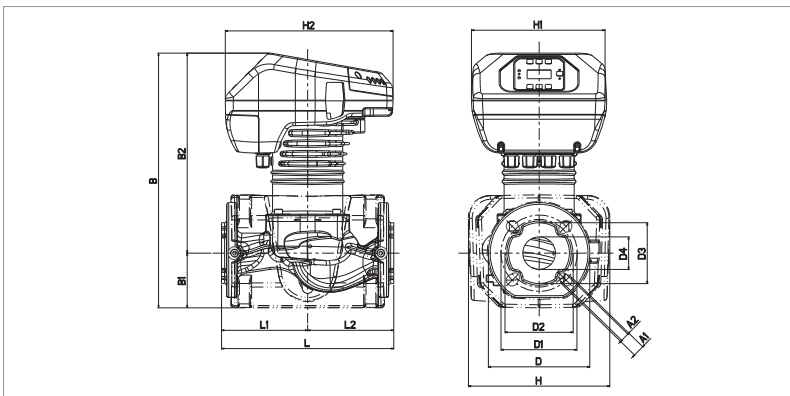

L	L1	L2	A1	A2	B	B1	B2
280	140	140	19	14	413	87	325

D	D1	D2	D3	D4	H	H1	H2
165	125	110	99	53	230	220	273

EVOPLUS SAN - WET ROTOR ELECTRONIC CIRCULATORS

Pumped liquid temperature range: from -10 °C to +110 °C - Maximum operating pressure: 16 bar (1600 kPa)

EVOPLUS B 40/340.65 SAN M

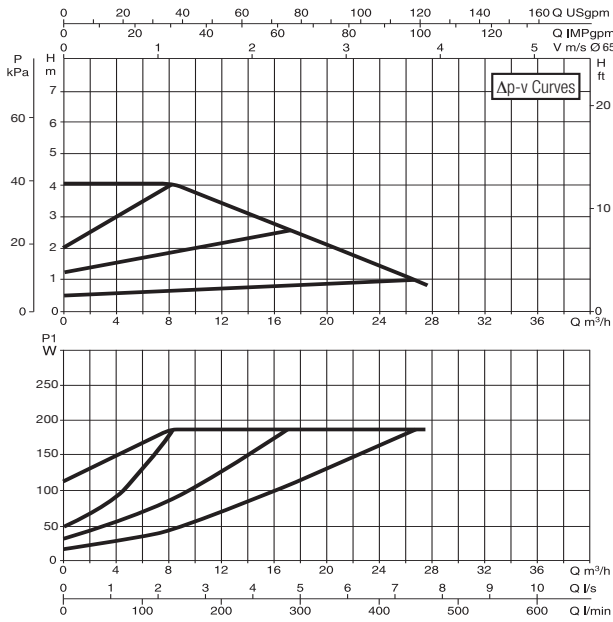

EVOPLUS B 60/340.65 SAN M

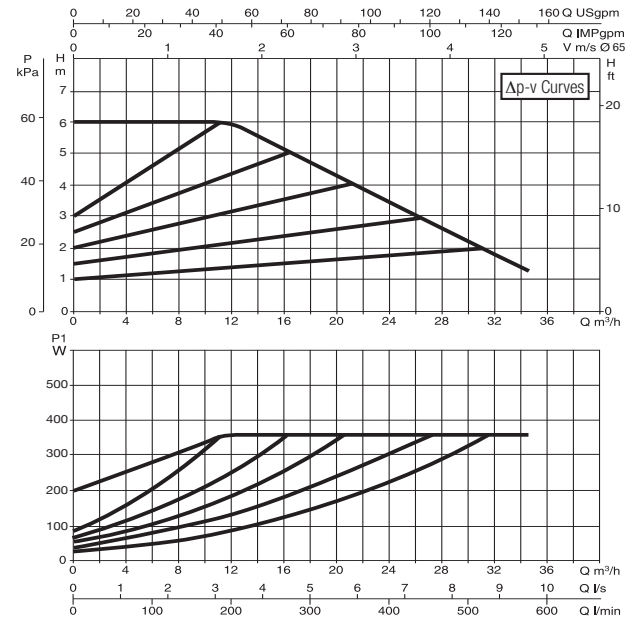

WET ROTOR ELECTRONIC CIRCULATORS

The curves are based on kinematic viscosity values = 1 mm²/s and density equal to 1000 kg/m³. Curve tolerance according to ISO 9906. Fixed speed curves available on the DNA.

MODEL	CENTRE DISTANCE mm	COUNTERFLANGES ON REQUEST	POWER INPUT 50/60 Hz	P1 MAX W	In A	MINIMUM SUCTION PRESSURE			WEIGHT Kg
						t°	90°	100°	
EVOPLUS B 40/340.65 SAN M	340	DN 65 PN 10	220/240 V	190	1,1	m.c.w.	20	25	27
EVOPLUS B 60/340.65 SAN M	340	DN 65 PN 10	220/240 V	355	1,8	m.c.w.	20	25	27,2

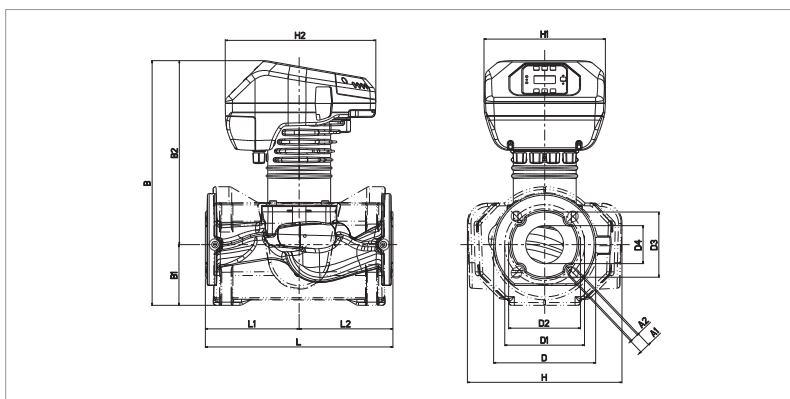

L	L1	L2	A1	A2	B	B1	B2
340	170	170	19	14	443	110	333

D	D1	D2	D3	D4	H	H1	H2
185	145	130	118	69	280	220	273

EVOPLUS SAN - WET ROTOR ELECTRONIC CIRCULATORS

Pumped liquid temperature range: from -10 °C to +110 °C - Maximum operating pressure: 16 bar (1600 kPa)

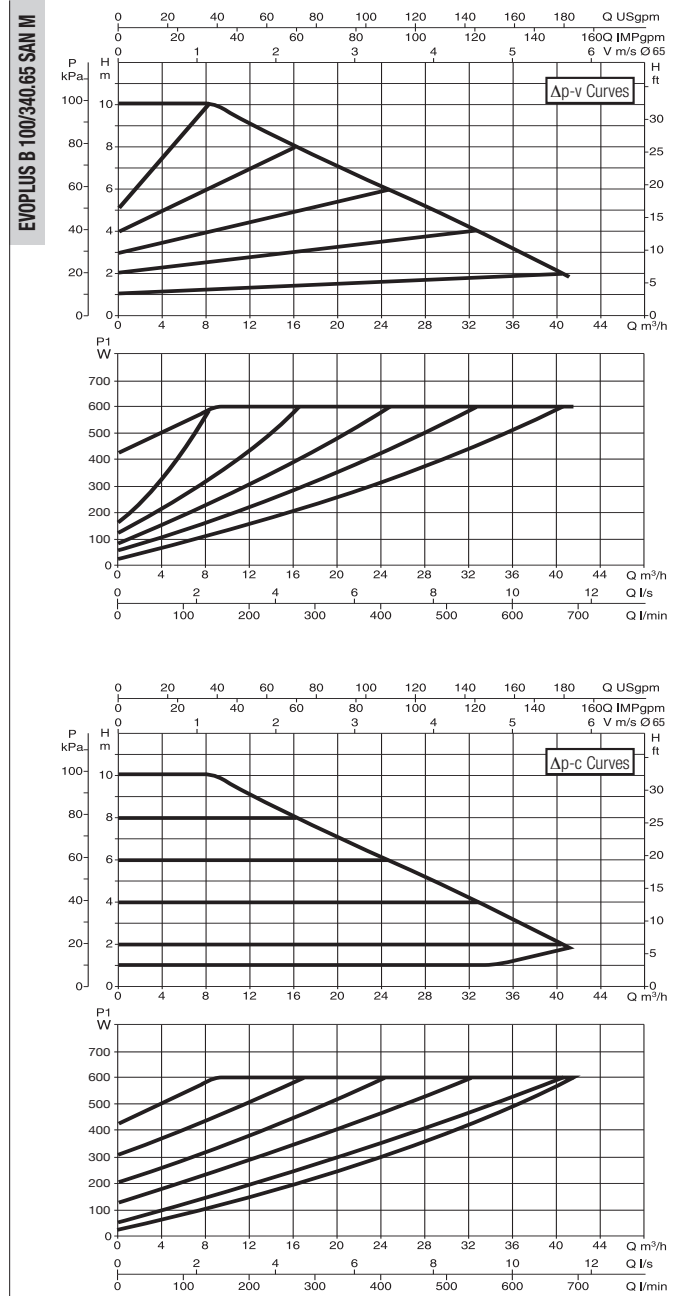
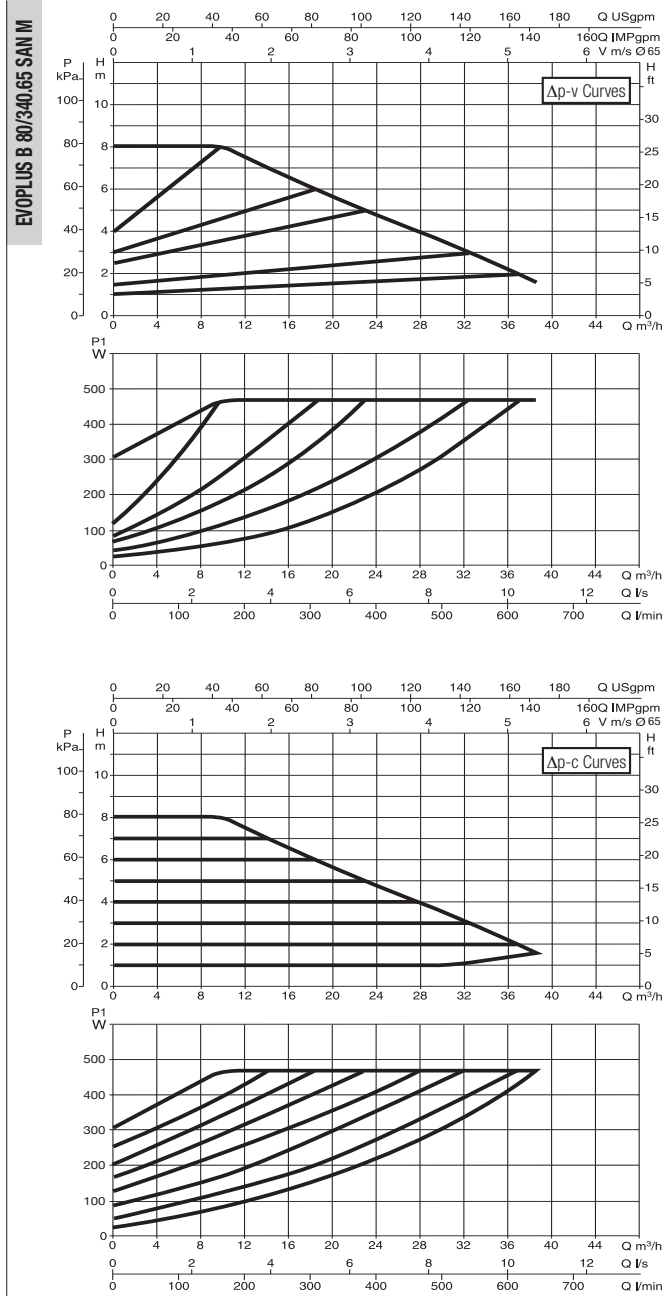

The curves are based on kinematic viscosity values = 1 mm²/s and density equal to 1000 kg/m³. Curve tolerance according to ISO 9906. Fixed speed curves available on the DNA.

MODEL	CENTRE DISTANCE mm	COUNTERFLANGES ON REQUEST	POWER INPUT 50/60 Hz	P1 MAX W	In A	MINIMUM SUCTION PRESSURE			WEIGHT Kg
						t°	90°	100°	
EVOPLUS B 80/340.65 SAN M	340	DN 65 PN 10	220/240 V	465	2,2	m.c.w.	20	25	27,8
EVOPLUS B 100/340.65 SAN M	340	DN 65 PN 10	220/240 V	590	2,8	m.c.w.	20	25	28

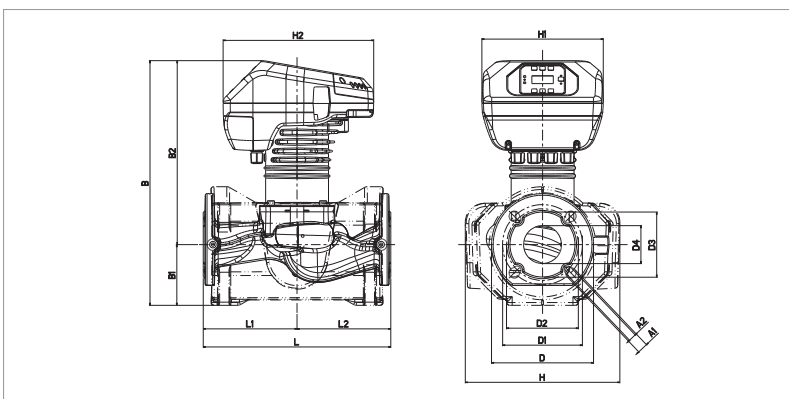

L	L1	L2	A1	A2	B	B1	B2
340	170	170	19	14	443	110	333

D	D1	D2	D3	D4	H	H1	H2
185	145	130	118	69	280	220	273

EVOPLUS SAN - WET ROTOR ELECTRONIC CIRCULATORS

Pumped liquid temperature range: from -10 °C to +110 °C - Maximum operating pressure: 16 bar (1600 kPa)

EVOPLUS B 120/340.65 SAN M

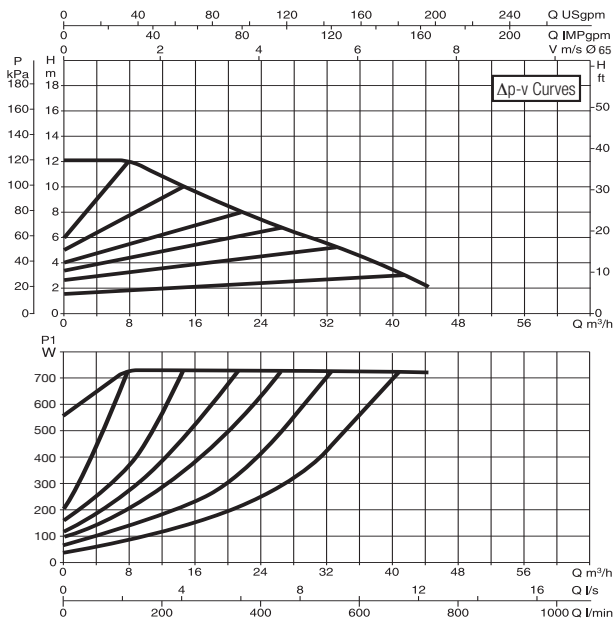

EVOPLUS B 150/340.65 SAN M

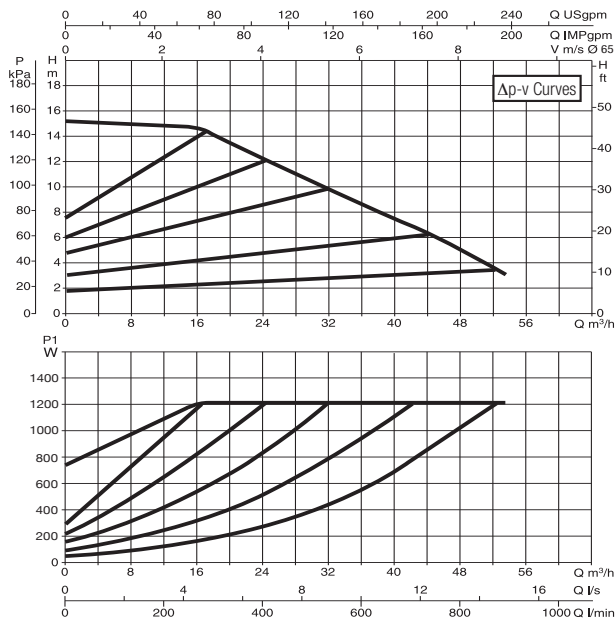

EVOPLUS B 120/340.65 SAN M

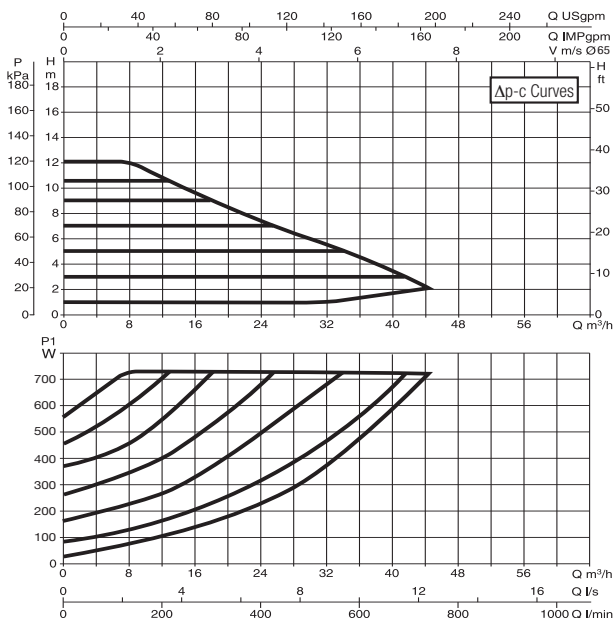

EVOPLUS B 150/340.65 SAN M

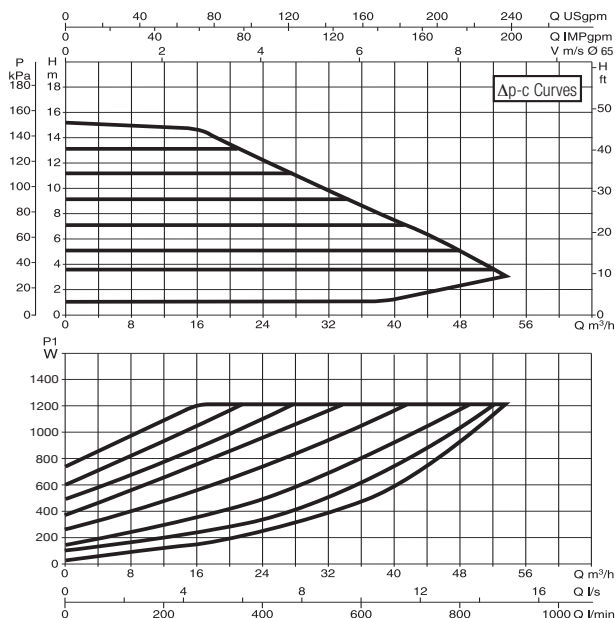

The curves are based on kinematic viscosity values = 1 mm²/s and density equal to 1000 kg/m³. Curve tolerance according to ISO 9906. Fixed speed curves available on the DNA.

MODEL	INTERASSE mm	COUNTERFLANGES ON REQUEST	POWER INPUT 50/60 Hz	P1 MAX W	In A	MINIMUM SUCTION PRESSURE			WEIGHT Kg
						t°	90°	100°	
EVOPLUS B 120/340.65 SAN M	340	DN 65 PN 10	220/240 V	730	3,45	m.c.w.	20	25	28,2
EVOPLUS B 150/340.65 SAN M	340	DN 65 PN 10	220/240 V	1210	5,5	m.c.w.	20	25	30

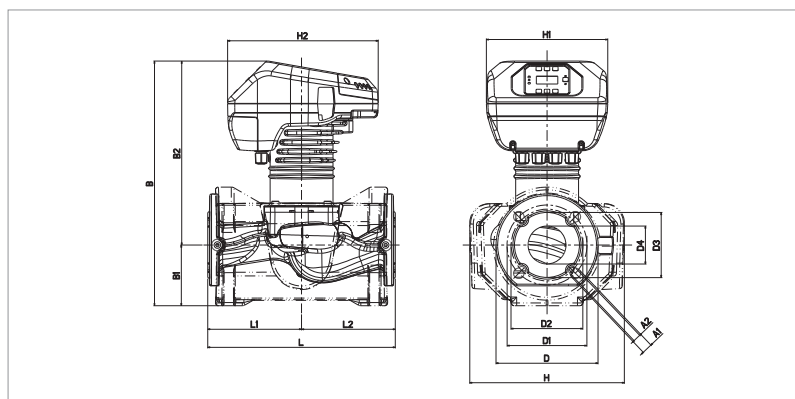

L	L1	L2	A1	A2	B	B1	B2
340	170	170	19	14	443	110	333

D	D1	D2	D3	D4	H	H1	H2
185	145	130	118	69	280	220	273



TECHNICAL DATA

Operating range: from 0,5 to 3,6 m³/h with head up to 6 metres

Pumped liquid temperature range: from -10°C to +110°C

Pumped liquid: clean, free from solids and mineral oils, non viscous, chemically neutral, close to the characteristics of water (max 30% glycol)

Maximum operating pressure: 10 bar (1000 kPa)

Minimum suction pressure: the values are given in the relative tables

Installation: with HORIZONTAL MOTOR SHAFT on discharge or return pipe, with suction port as close as possible to expansion vessel, above maximum boiler level and as far as possible from bends, elbows, and circuit branches to avoid water turbulence with consequent noise

Protection level: corresponding to IP 44

Insulation class: F

Cable grommet: PG 11

Special executions on requests: alternative voltages and/or frequencies

Optional accessories: r³/₄"F - 1"F - 1¹/₄"F - 1¹/₄"M unions

DN20-DN25-DN32 oval counter-flanges

DN32/PN6 round counter-flanges

APPLICATIONS

Pump for hot water circulation in domestic central heating and air conditioning systems of the closed circuit pressurized type or open circuit type.

CONSTRUCTION FEATURES

Enbloc body composed of hydraulic section in cast iron and wet rotor motor. Motor casing in die cast aluminium. Impeller in technopolymer. Motor shaft in hardened stainless steel held in graphite bearings lubricated by the pumping medium.

Rotor protective jacket, stator jacket, and closing flange in stainless steel.

Ceramic thrust ring, ethylene-propylene seal rings and brass air breather plug. The two-pole asynchronous wet-rotor motor is resistance protected and does not require any form of overload protection.

Three-speed operation.

Protection rating: IP 44

Insulation class: F

Cable gland: PG 11

Installation: with horizontal motor shaft.

Standard voltage input: single-phase 230 V / 50 Hz

Special versions on request - alternative voltages and/or frequencies

MATERIALS

N.	PARTS	MATERIALS
1	PUMP BODY	CAST IRON
4	IMPELLER	TECHNOPOLYMER
7A	MOTOR SHAFT	STAINLESS STEEL
7B	ROTOR	-
8	STATOR	-
9	CAPACITOR	-
10	MOTOR CASING	DIE CAST ALUMINIUM
11	BREATHER PLUG	BRASS
100	TERMINAL BOX	-
127	SEAL RING	ETHYLENE POLYPROPYLENE
128	STATOR JACKET	STAINLESS STEEL
129	ROTOR JACKET	STAINLESS STEEL
130	CLOSING FLANGE	STAINLESS STEEL
131	THRUST RING SUPPORT	ETHYLENE PROPYLENE
132	BUSHINGS	GRAPHITE
133	THRUST RING	CERAMIC

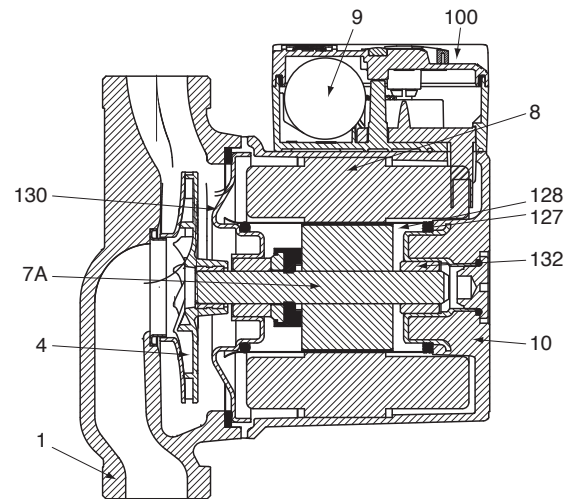

**- Legend:
(example)**

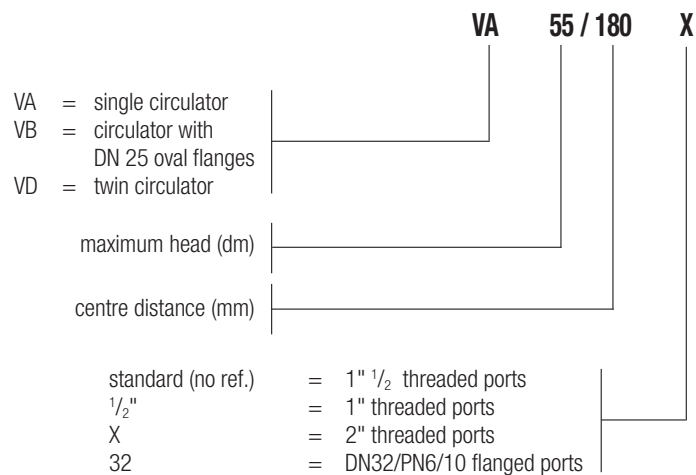

PERFORMANCE RANGE

The performance curves are based on kinematic viscosity values = 1 mm²/s and density equal to 1000 kg/m³. Curve tolerance according to ISO 9906.

GRAPHIC SELECTION TABLE

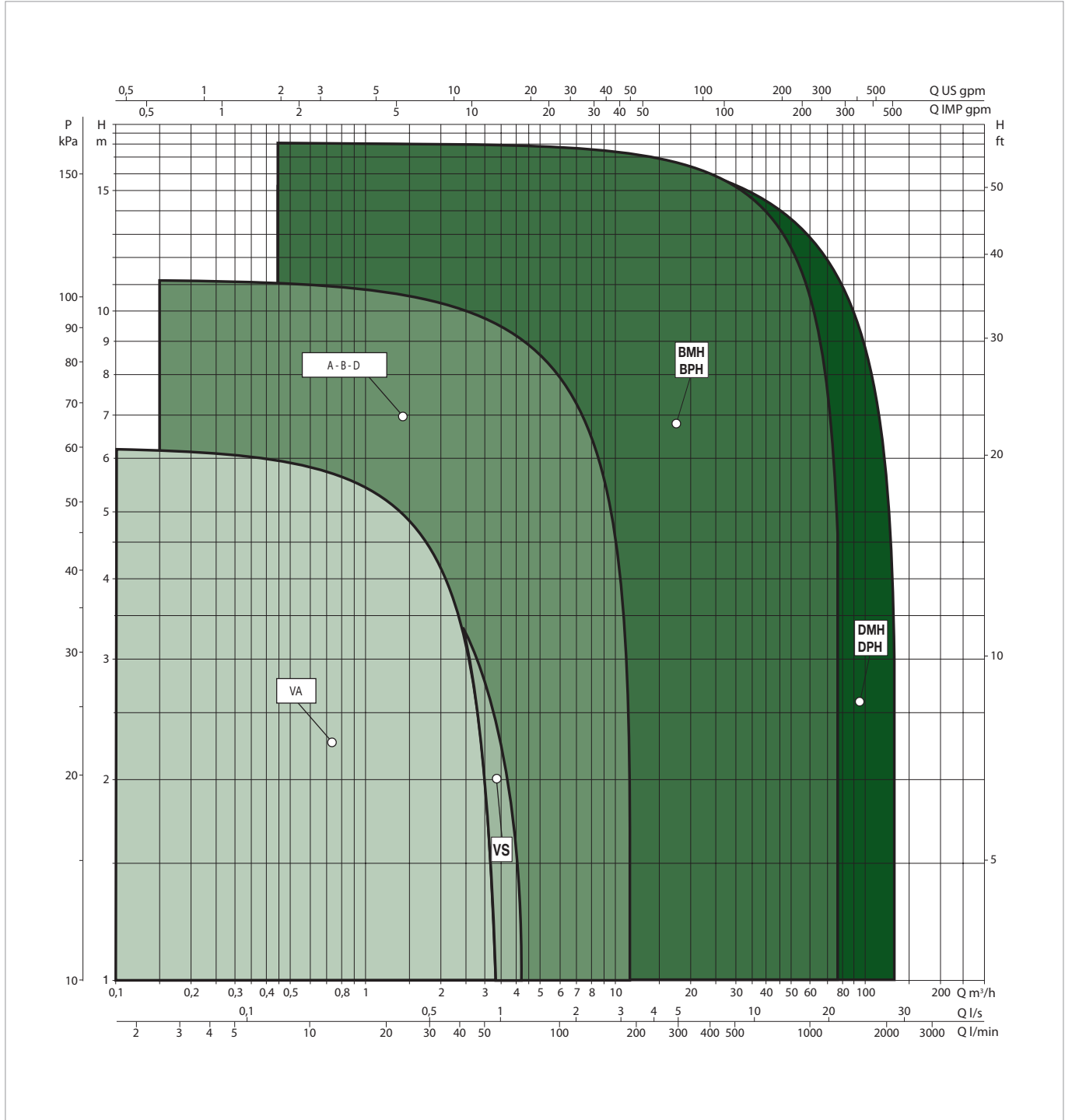

SELECTION TABLE - VA SINGLE WITH UNIONS

MODEL	Q=m ³ /h	0	0,6	1,2	1,8	2,4	3	4,2
	Q=l/min	0	10	20	30	40	50	70
VA 25/130	H (m)	2,71	2,45	2,15	1,75	1,2	0,6	
VA 25/180		2,71	2,45	2,15	1,75	1,2	0,6	
VA 25/180X		2,71	2,45	2,15	1,75	1,2	0,6	
VA 35/130		4,3	3,9	3,4	2,8	2,15	1,4	
VA 35/130-1/2"		4,3	3,9	3,4	2,8	2,15	1,4	
VA 35/180		4,3	3,9	3,4	2,8	2,15	1,4	
VA 35/180 X		4,3	3,9	3,4	2,8	2,15	1,4	
VA 55/130		5,4	4,7	4,5	3,3	2,6	1,75	0,85
VA 55/130-1/2"		5,4	4,7	4,5	3,3	2,6	1,75	0,85
VA 55/180		5,4	4,7	4,5	3,3	2,6	1,75	0,85
VA 55/180 X		5,4	4,7	4,5	3,3	2,6	1,75	0,85
VA 65/130		6,3	5,8	5,3	4,3	3,4	2,4	
VA 65/130-1/2"		6,3	5,8	5,3	4,3	3,4	2,4	
VA 65/180		6,3	5,8	5,3	4,3	3,4	2,4	
VA 65/180 X		6,3	5,8	5,3	4,3	3,4	2,4	

VA 25/130 - WET ROTOR CIRCULATORS

Pumped liquid temperature range: from -10 °C to +110 °C - Maximum operating pressure: 10 bar (1000 kPa)

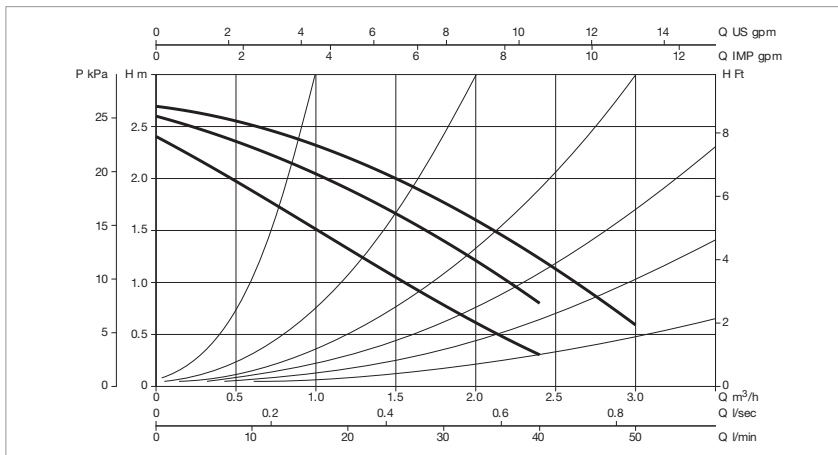
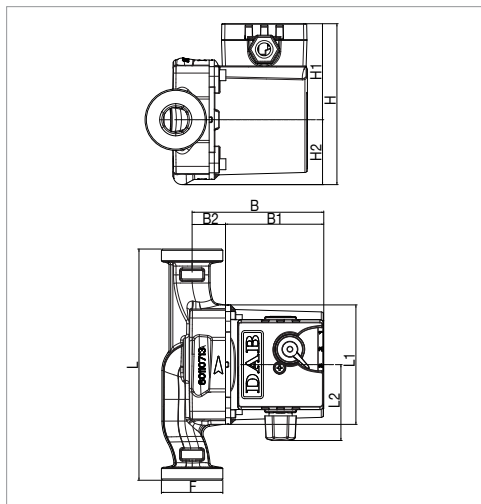

The performance curves are based on kinematic viscosity values = 1 mm²/s and density equal to 1000 kg/m³. Curve tolerance according to ISO 9906.

MODEL	CENTRE DISTANCE mm	POWER INPUT 50 Hz	UNIONS ON REQUEST		ELECTRICAL DATA						MINIMUM SUCTION PRESSURE	
			STANDARDISED	SPECIAL	SPEED	REV. 1/min	P1 MAX W	In A	CAPACITOR		t°	90 °
VA 25/130	130	1x230 V ~	1" F	¾" F - 1¼" M	3	2655	43	0,19	1,5	450	m.c.w.	1,5
					2	2380	38	0,17				
					1	1680	31	0,15				

MODEL	L	L1	L2	B	B1	B2	H	H1	H2	F	PACKING DIMENSIONS			VOLUME m³	WEIGHT kg
											L	B	H		
VA 25/130	130	93	59	102,5	76,5	26	125,5	75	50,5	1 ½" 1 ½"	135	135	150	0,0027	2,7

VA 25/180 - WET ROTOR CIRCULATORS

Pumped liquid temperature range: from -10 °C to +110 °C - Maximum operating pressure: 10 bar (1000 kPa)

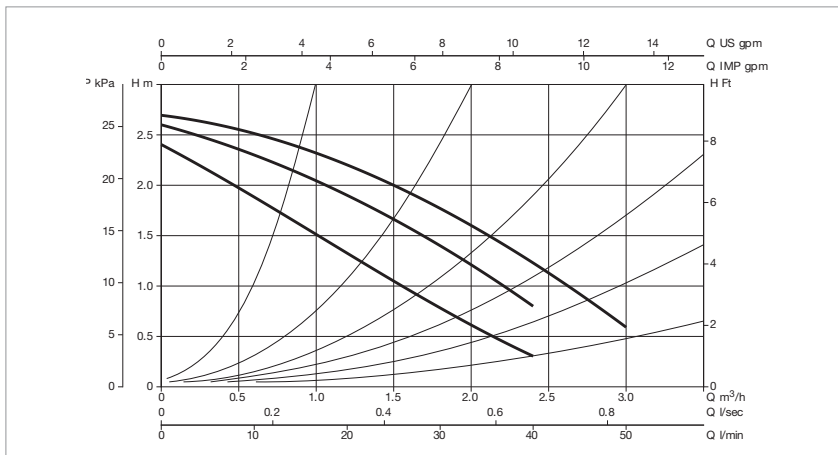
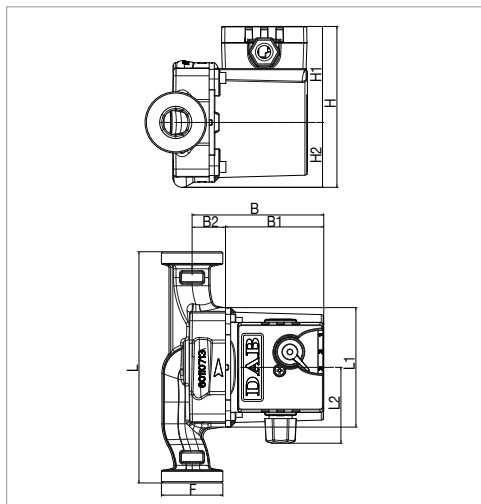

The performance curves are based on kinematic viscosity values = 1 mm²/s and density equal to 1000 kg/m³. Curve tolerance according to ISO 9906.

MODEL	CENTRE DISTANCE mm	POWER INPUT 50 Hz	UNIONS ON REQUEST		ELECTRICAL DATA						MINIMUM SUCTION PRESSURE	
			STANDARDISED	SPECIAL	SPEED	REV. 1/min	P1 MAX W	In A	CAPACITOR		t°	90 °
VA 25/180	180	1x230 V ~	1" F	¾" F - 1¼" M	3	2655	43	0,19	1,5	450	m.c.w.	1,5
					2	2380	38	0,17				
					1	1680	41	0,15				

MODEL	L	L1	L2	B	B1	B2	H	H1	H2	F	PACKING DIMENSIONS			VOLUME m³	WEIGHT kg
											L	B	H		
VA 25/180	180	93	59	102,5	76,5	26	125,5	75	50,5	1 ½" 1 ½"	130	190	150	0,0037	2,8

VA 25/180X - WET ROTOR CIRCULATORS

Pumped liquid temperature range: from -10 °C to +110 °C - Maximum operating pressure: 10 bar (1000 kPa)

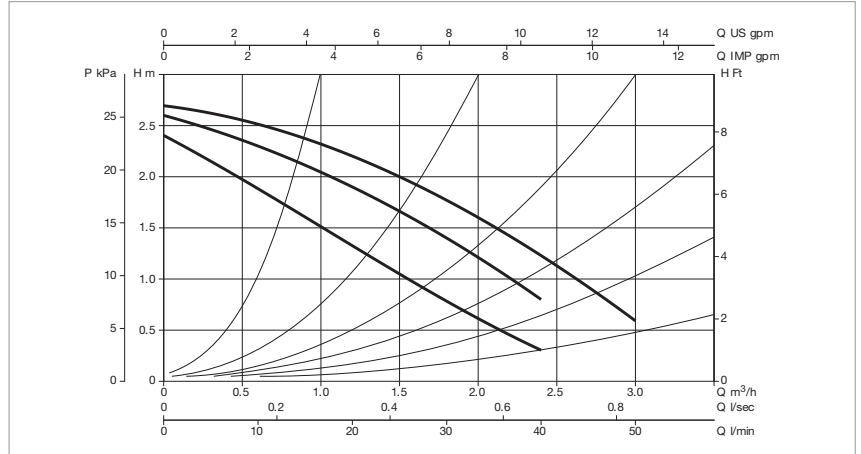
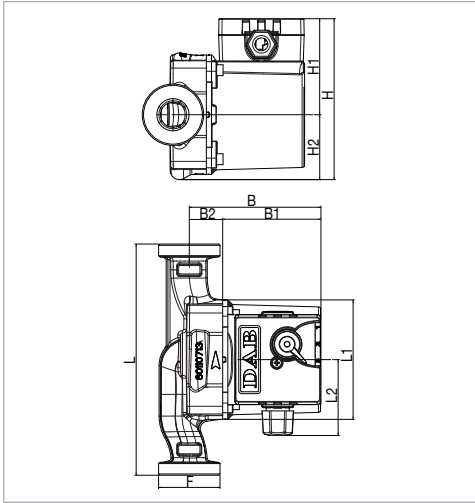

The performance curves are based on kinematic viscosity values = 1 mm²/s and density equal to 1000 kg/m³. Curve tolerance according to ISO 9906.

MODEL	CENTRE DISTANCE mm	POWER INPUT 50 Hz	UNIONS ON REQUEST		ELECTRICAL DATA						MINIMUM SUCTION PRESSURE	
			STANDARDISED	SPECIAL	SPEED	REV. 1/min	P1 MAX W	In A	CAPACITOR		t°	90 °
									µF	Vc		
VA 25/180X	180	1x230 V ~	1" ¼" F	-	3	2655	43	0,19	1,57	450	m.c.w.	1,5
					2	2380	48	0,17				
					1	1680	31	0,15				

MODEL	L	L1	L2	B	B1	B2	H	H1	H2	F	PACKING DIMENSIONS			VOLUME m ³	WEIGHT kg
											L	B	H		
VA 25/180X	180	93	59	102,5	76,5	26	125,5	75	50,5	2"	130	190	150	0,0037	2,9

VA 35/130 - WET ROTOR CIRCULATORS

Pumped liquid temperature range: from -10 °C to +110 °C - Maximum operating pressure: 10 bar (1000 kPa)

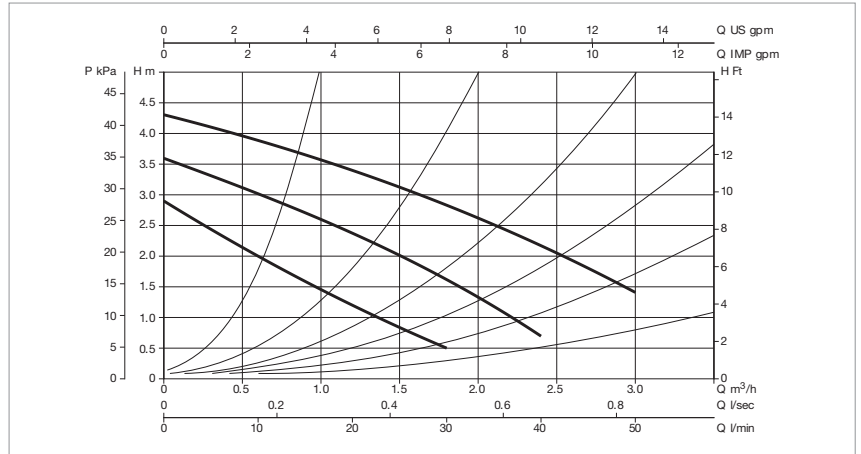
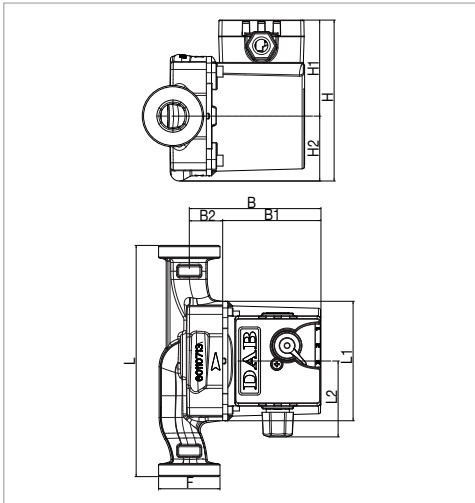

The performance curves are based on kinematic viscosity values = 1 mm²/s and density equal to 1000 kg/m³. Curve tolerance according to ISO 9906.

MODEL	CENTRE DISTANCE mm	POWER INPUT 50 Hz	UNIONS ON REQUEST		ELECTRICAL DATA						MINIMUM SUCTION PRESSURE	
			STANDARDISED	SPECIAL	SPEED	REV. 1/min	P1 MAX W	In A	CAPACITOR		t°	90 °
									µF	Vc		
VA 35/130	130	1x230 V ~	1" F	¾" F - 1¼" M	3	2465	56	0,25	1,7	450	m.c.w.	1,5
					2	1930	50	0,22				
					1	1150	35	0,16				

MODEL	L	L1	L2	B	B1	B2	H	H1	H2	F	PACKING DIMENSIONS			VOLUME m ³	WEIGHT kg
											L	B	H		
VA 35/130	130	93	59	102,5	76,5	26	125,5	75	50,5	1 ½" 1 ½"	135	135	150	0,0027	2,7

VA 35/130 - 1/2" - WET ROTOR CIRCULATORS

Pumped liquid temperature range: from -10 °C to +110 °C - Maximum operating pressure: 10 bar (1000 kPa)

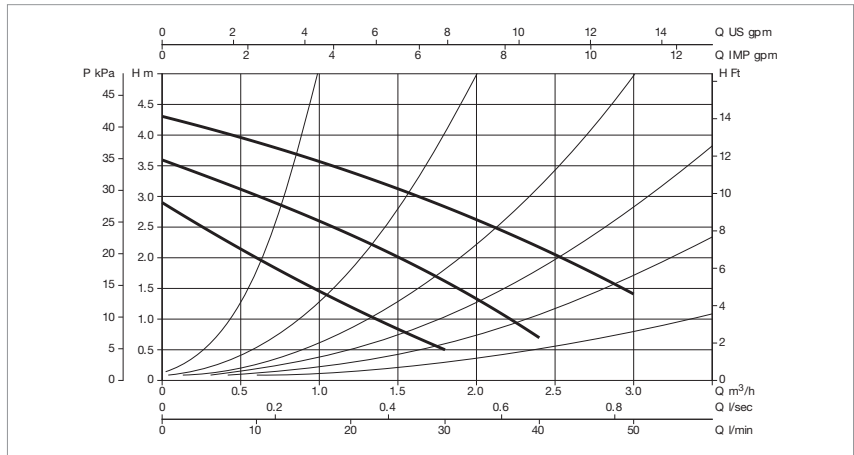
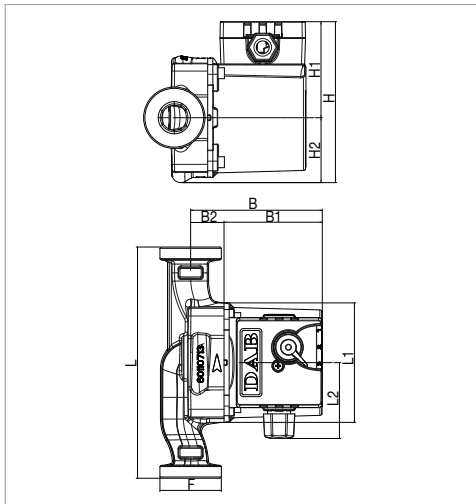

The performance curves are based on kinematic viscosity values = 1 mm²/s and density equal to 1000 kg/m³. Curve tolerance according to ISO 9906.

MODEL	CENTRE DISTANCE mm	POWER INPUT 50 Hz	UNIONS ON REQUEST		ELECTRICAL DATA						MINIMUM SUCTION PRESSURE	
			STANDARDISED	SPECIAL	SPEED	REV. 1/min	P1 MAX W	In A	CAPACITOR		t°	90 °
VA 35/130 - 1/2"	130	1x230 V ~	-	-	3	2465	56	0,25	1,7	450	m.c.w.	1,5
					2	1930	50	0,22				
					1	1150	35	0,16				

MODEL	L	L1	L2	B	B1	B2	H	H1	H2	F	PACKING DIMENSIONS			VOLUME m³	WEIGHT kg
											L	B	H		
VA 35/130 - 1/2"	130	93	59	102,5	76,5	26	125,5	75	50,5	1"	135	135	150	0,0027	2,6

VA 35/180 - WET ROTOR CIRCULATORS

Pumped liquid temperature range: from -10 °C to +110 °C - Maximum operating pressure: 10 bar (1000 kPa)

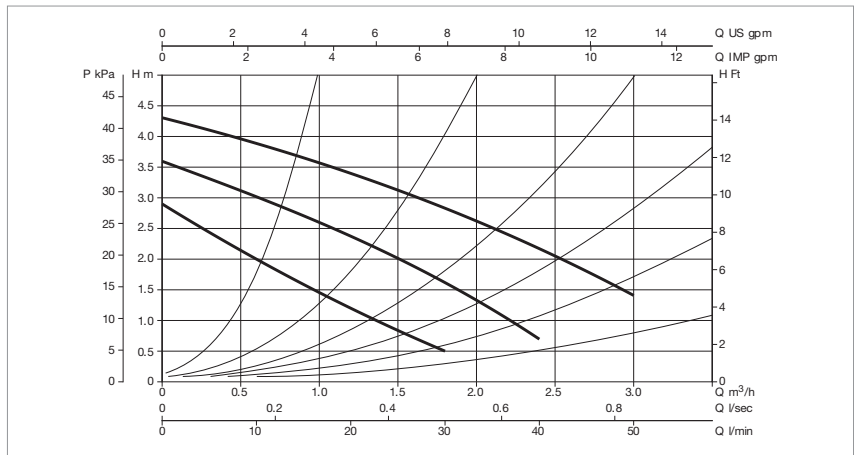
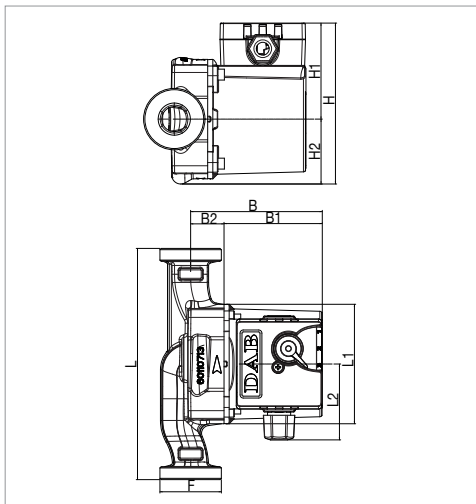

The performance curves are based on kinematic viscosity values = 1 mm²/s and density equal to 1000 kg/m³. Curve tolerance according to ISO 9906.

MODEL	CENTRE DISTANCE mm	POWER INPUT 50 Hz	UNIONS ON REQUEST		ELECTRICAL DATA						MINIMUM SUCTION PRESSURE	
			STANDARDISED	SPECIAL	SPEED	REV. 1/min	P1 MAX W	In A	CAPACITOR		t°	90 °
VA 35/180	180	1x230 V ~	1" F	¾" F - 1¼" M	3	2465	56	0,25	1,7	450	m.c.w.	1,5
					2	1930	50	0,22				
					1	1150	35	0,16				

MODEL	L	L1	L2	B	B1	B2	H	H1	H2	F	PACKING DIMENSIONS			VOLUME m³	WEIGHT kg
											L	B	H		
VA 35/180	180	93	59	102,5	76,5	26	125,5	75	50,5	1 ½" 1 ½"	130	190	150	0,0037	2,8

VA 35/180X - WET ROTOR CIRCULATORS

Pumped liquid temperature range: from -10 °C to +110 °C - Maximum operating pressure: 10 bar (1000 kPa)

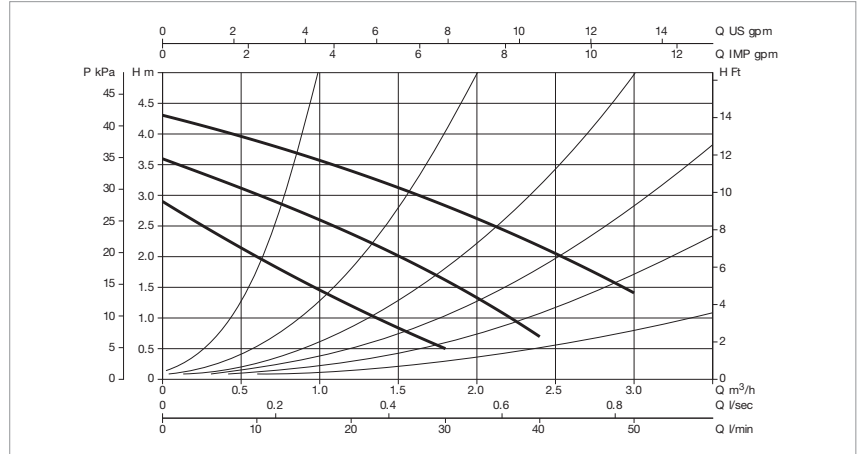
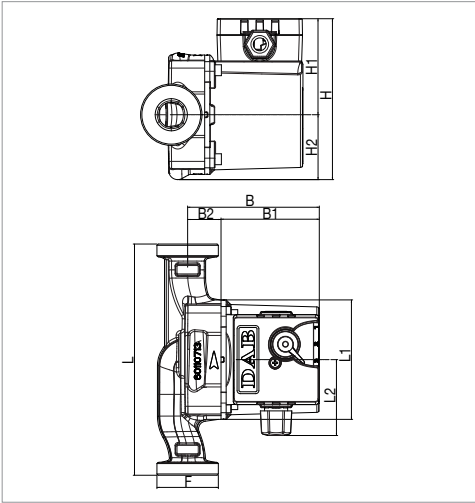

The performance curves are based on kinematic viscosity values = 1 mm²/s and density equal to 1000 kg/m³. Curve tolerance according to ISO 9906.

MODEL	CENTRE DISTANCE mm	POWER INPUT 50 Hz	UNIONS ON REQUEST		ELECTRICAL DATA						MINIMUM SUCTION PRESSURE	
			STANDARDISED	SPECIAL	SPEED	REV. 1/min	P1 MAX W	In A	CAPACITOR μF Vc		t°	90 °
VA 35/180X	180	1x230 V ~	-	-	3	2465	56	0,25	1,7	450	m.c.w.	1,5
					2	1930	50	0,22				
					1	1150	35	0,16				

MODEL	L	L1	L2	B	B1	B2	H	H1	H2	F	PACKING DIMENSIONS			VOLUME m ³	WEIGHT kg
											L	B	H		
VA 35/180X	180	93	49	102,5	76,5	26	125,5	75	50,5	2"	130	190	150	0,0037	2,9

VA 55/130 - WET ROTOR CIRCULATORS

Pumped liquid temperature range: from -10 °C to +110 °C - Maximum operating pressure: 10 bar (1000 kPa)

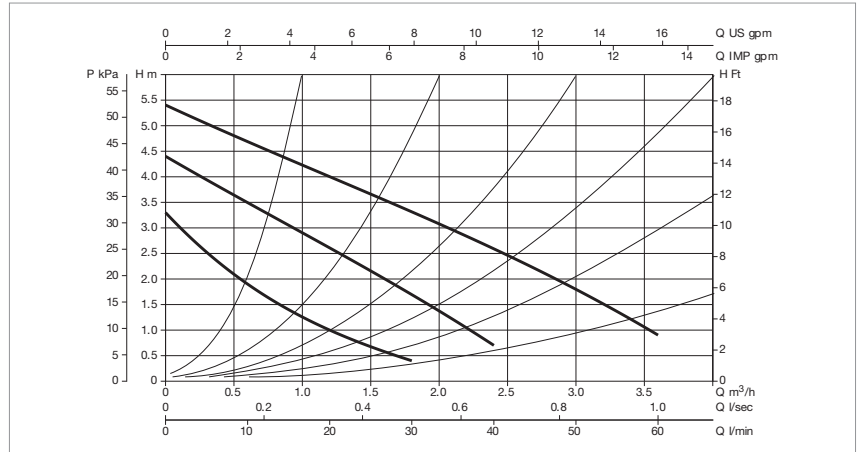
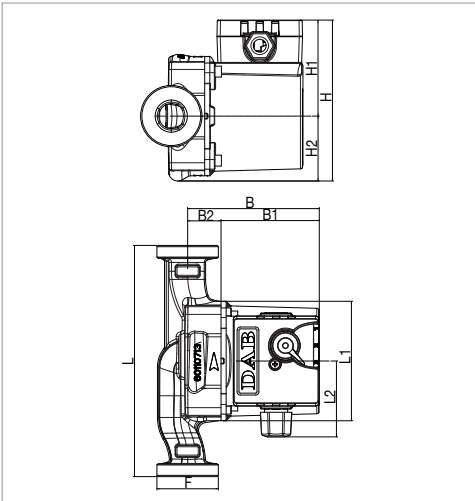

The performance curves are based on kinematic viscosity values = 1 mm²/s and density equal to 1000 kg/m³. Curve tolerance according to ISO 9906.

MODEL	CENTRE DISTANCE mm	POWER INPUT 50 Hz	UNIONS ON REQUEST		ELECTRICAL DATA						MINIMUM SUCTION PRESSURE	
			STANDARDISED	SPECIAL	SPEED	REV. 1/min	P1 MAX W	In A	CAPACITOR μF Vc		t°	90 °
VA 55/130	130	1x230 V ~	1" F	¾" F - 1¼" M	3	2400	70	0,3	1,7	450	m.c.w.	1,5
					2	1600	58	0,26				
					1	930	36	0,17				

MODEL	L	L1	L2	B	B1	B2	H	H1	H2	F	PACKING DIMENSIONS			VOLUME m ³	WEIGHT kg
											L	B	H		
VA 55/130	130	93	59	102,5	76,5	26	125,5	75	50,5	1 ½" 1 ½"	135	135	150	0,0027	2,7

VA 55/130 - 1/2" - WET ROTOR CIRCULATORS

Pumped liquid temperature range: from -10 °C to +110 °C - Maximum operating pressure: 10 bar (1000 kPa)

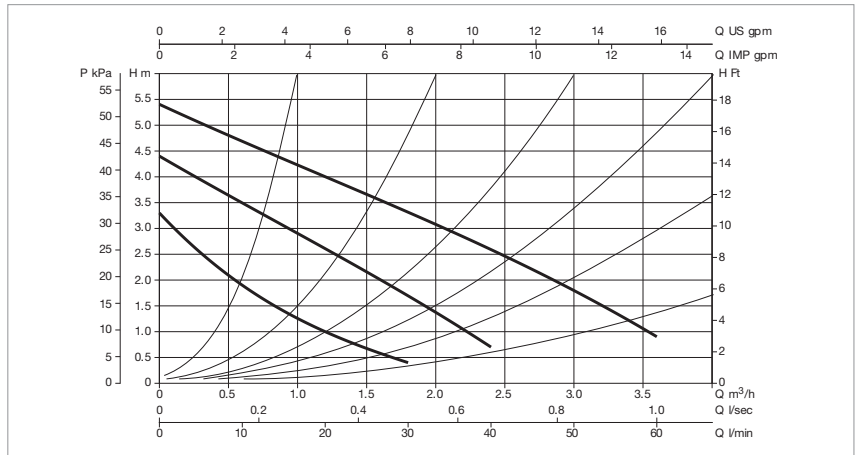
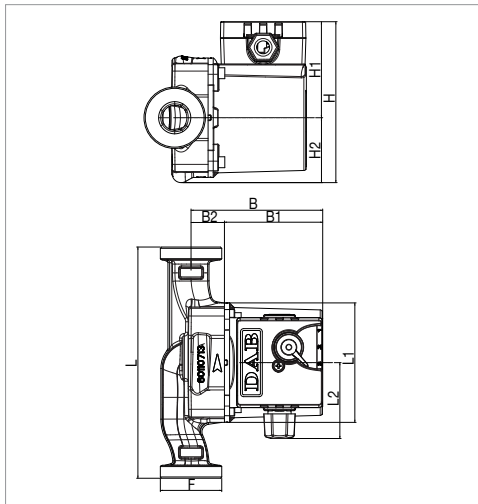

The performance curves are based on kinematic viscosity values = 1 mm²/s and density equal to 1000 kg/m³. Curve tolerance according to ISO 9906.

MODEL	CENTRE DISTANCE mm	POWER INPUT 50 Hz	UNIONS ON REQUEST		ELECTRICAL DATA						MINIMUM SUCTION PRESSURE		
			STANDARDISED	SPECIAL	SPEED	REV. 1/min	P1 MAX W	In A	CAPACITOR		t°	90 °	
										µF	Vc		
VA 55/130 - 1/2"	130	1x230 V ~	-	-	3	2400	70	0,3	1,7	450	m.c.w.	1,5	
					2	1600	58	0,26					
					1	930	36	0,17					

MODEL	L	L1	L2	B	B1	B2	H	H1	H2	F	PACKING DIMENSIONS			VOLUME m³	WEIGHT kg
											L	B	H		
VA 55/130 - 1/2"	130	93	59	102,5	76,5	26	125,5	75	50,5	1"	135	135	150	0,0027	2,6

VA 55/180 - WET ROTOR CIRCULATORS

Pumped liquid temperature range: from -10 °C to +110 °C - Maximum operating pressure: 10 bar (1000 kPa)

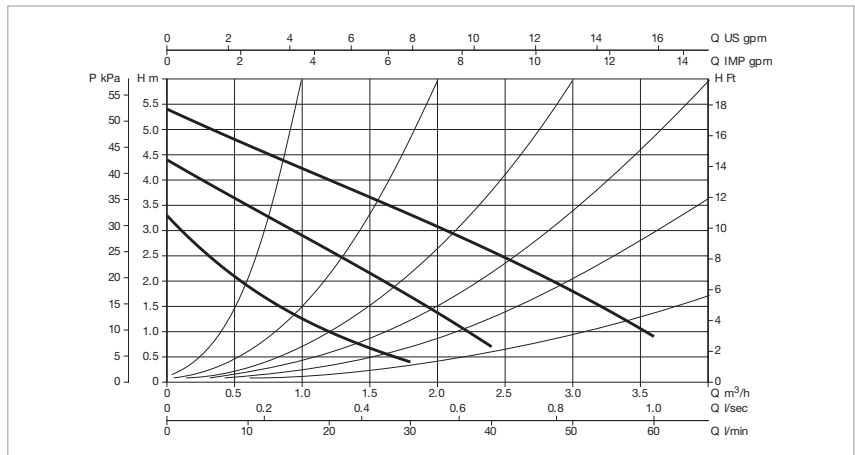
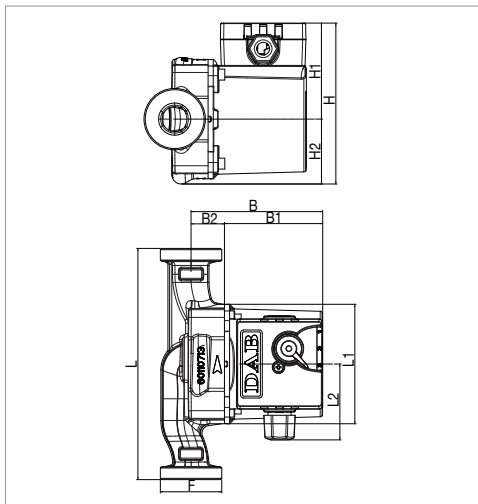

The performance curves are based on kinematic viscosity values = 1 mm²/s and density equal to 1000 kg/m³. Curve tolerance according to ISO 9906.

MODEL	CENTRE DISTANCE mm	POWER INPUT 50 Hz	UNIONS ON REQUEST		ELECTRICAL DATA						MINIMUM SUCTION PRESSURE		
			STANDARDISED	SPECIAL	SPEED	REV. 1/min	P1 MAX W	In A	CAPACITOR		t°	90 °	
										µF	Vc		
VA 55/180	180	1x230 V ~	1" F	¾" F - 1¼" M	3	2400	70	0,3	1,7	450	m.c.w.	1,5	
					2	1600	58	0,26					
					1	930	36	0,17					

MODEL	L	L1	L2	B	B1	B2	H	H1	H2	F	PACKING DIMENSIONS			VOLUME m³	WEIGHT kg
											L	B	H		
VA 55/180	180	93	59	102,5	76,5	26	125,5	75	50,5	1 ½" 1 ½"	130	190	150	0,0037	2,8

VA 55/180X - WET ROTOR CIRCULATORS

Pumped liquid temperature range: from -10 °C to +110 °C - Maximum operating pressure: 10 bar (1000 kPa)

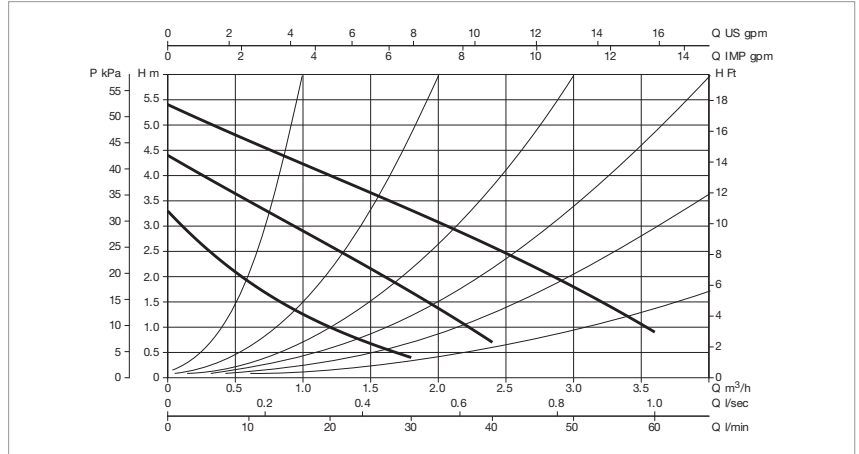
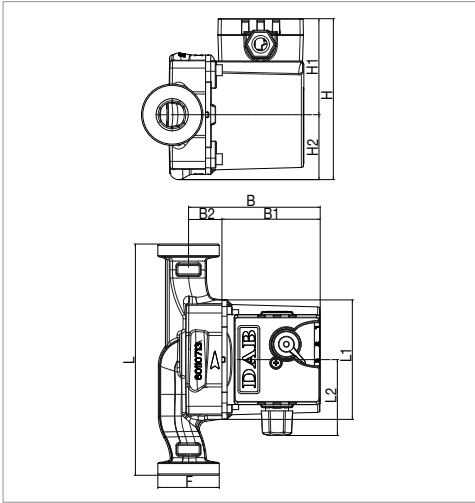

The performance curves are based on kinematic viscosity values = 1 mm²/s and density equal to 1000 kg/m³. Curve tolerance according to ISO 9906.

MODEL	CENTRE DISTANCE mm	POWER INPUT 50 Hz	UNIONS ON REQUEST		ELECTRICAL DATA						MINIMUM SUCTION PRESSURE	
			STANDARDISED	SPECIAL	SPEED	REV. 1/min	P1 MAX W	In A	CAPACITOR		1°	90°
VA 55/180X	180	1x230 V ~	1" ¼" F	-	3	2400	70	0,3	1,7	450	m.c.w.	1,5
					2	1600	58	0,26				
					1	930	36	0,17				

MODEL	L	L1	L2	B	B1	B2	H	H1	H2	F	PACKING DIMENSIONS			VOLUME m ³	WEIGHT kg
											L	B	H		
VA 55/180X	180	93	59	102,5	76,5	26	125,5	75	50,5	2"	130	190	150	0,0037	2,9

VA 65/130 - WET ROTOR CIRCULATORS

Pumped liquid temperature range: from -10 °C to +110 °C - Maximum operating pressure: 10 bar (1000 kPa)

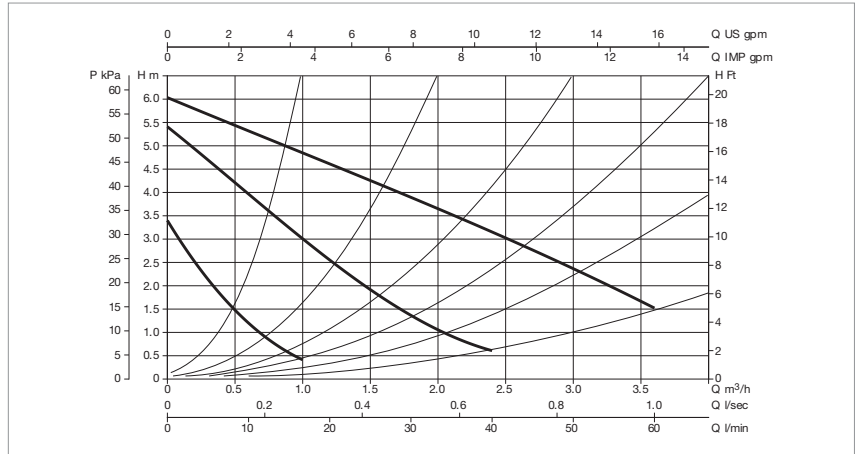
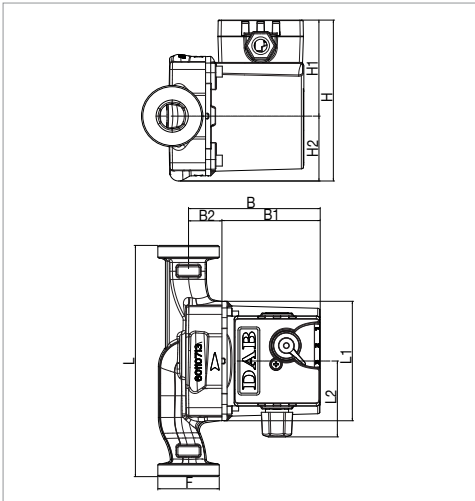

The performance curves are based on kinematic viscosity values = 1 mm²/s and density equal to 1000 kg/m³. Curve tolerance according to ISO 9906.

MODEL	CENTRE DISTANCE mm	POWER INPUT 50 Hz	UNIONS ON REQUEST		ELECTRICAL DATA						MINIMUM SUCTION PRESSURE	
			STANDARDISED	SPECIAL	SPEED	REV. 1/min	P1 MAX W	In A	CAPACITOR		1°	90°
VA 65/130	130	1x230 V ~	1" F	¾" F - 1¼" M	3	2310	78	0,34	2	450	m.c.w.	2,5
					2	1532	59	0,26				
					1	880	37	0,17				

MODEL	L	L1	L2	B	B1	B2	H	H1	H2	F	PACKING DIMENSIONS			VOLUME m ³	WEIGHT kg
											L	B	H		
VA 65/130	130	93	59	102,5	76,5	26	125,5	75	50,5	1 ½"	135	135	150	0,0027	2,7

VA 65/130 - 1/2" - WET ROTOR CIRCULATORS

Pumped liquid temperature range: from -10 °C to +110 °C - Maximum operating pressure: 10 bar (1000 kPa)

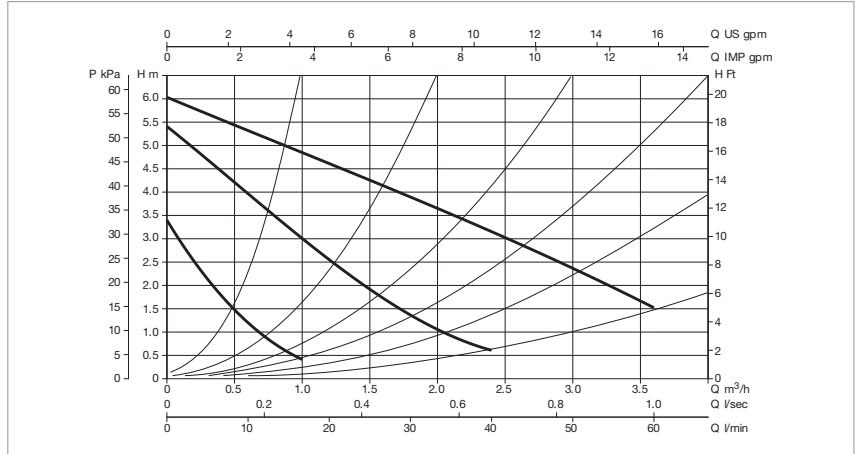
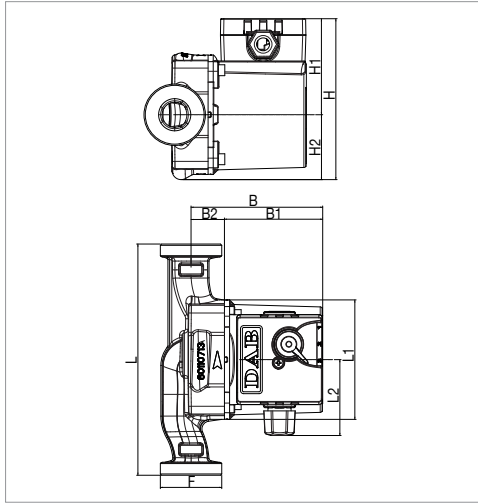

The performance curves are based on kinematic viscosity values = 1 mm²/s and density equal to 1000 kg/m³. Curve tolerance according to ISO 9906.

MODEL	CENTRE DISTANCE mm	POWER INPUT 50 Hz	UNIONS ON REQUEST		ELECTRICAL DATA						MINIMUM SUCTION PRESSURE		
			STANDARDISED	SPECIAL	SPEED	REV. 1/min	P1 MAX W	In A	CAPACITOR		t°	90 °	
										µF	Vc		
VA 65/130 - 1/2"	130	1x230 V ~	-	-	3	2310	78	0,34	2	450	m.c.w.	2,5	
					2	1532	59	0,26					
					1	880	37	0,17					

MODEL	L	L1	L2	B	B1	B2	H	H1	H2	F	PACKING DIMENSIONS			VOLUME m³	WEIGHT kg
											L	B	H		
VA 65/130 - 1/2"	130	93	59	102,5	76,5	26	125,5	75	50,5	1"	135	135	150	0,0027	2,6

VA 65/180 - WET ROTOR CIRCULATORS

Pumped liquid temperature range: from -10 °C to +110 °C - Maximum operating pressure: 10 bar (1000 kPa)

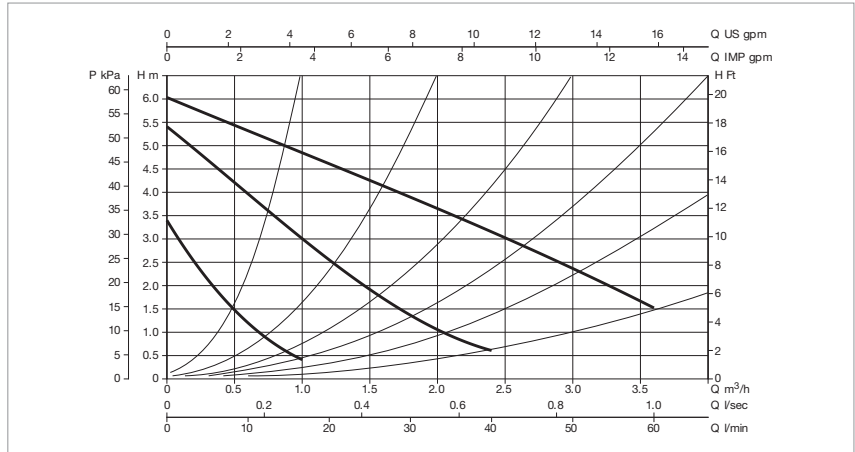
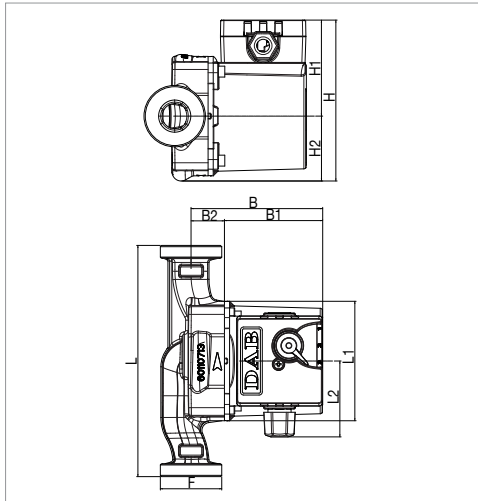

The performance curves are based on kinematic viscosity values = 1 mm²/s and density equal to 1000 kg/m³. Curve tolerance according to ISO 9906.

MODEL	CENTRE DISTANCE mm	POWER INPUT 50 Hz	UNIONS ON REQUEST		ELECTRICAL DATA						MINIMUM SUCTION PRESSURE		
			STANDARDISED	SPECIAL	SPEED	REV. 1/min	P1 MAX W	In A	CAPACITOR		t°	90 °	
										µF	Vc		
VA 65/180	180	1x230 V ~	1" F	¾" F - 1¼" M	3	2310	78	0,34	2	450	m.c.w.	2,5	
					2	1532	59	0,26					
					1	880	37	0,17					

MODEL	L	L1	L2	B	B1	B2	H	H1	H2	F	PACKING DIMENSIONS			VOLUME m³	WEIGHT kg
											L	B	H		
VA 65/180	180	93	59	102,5	76,5	26	125,5	75	50,5	1 ½"	130	190	150	0,0037	2,7

VA 65/180X - WET ROTOR CIRCULATORS

Pumped liquid temperature range: from -10 °C to +110 °C - Maximum operating pressure: 10 bar (1000 kPa)

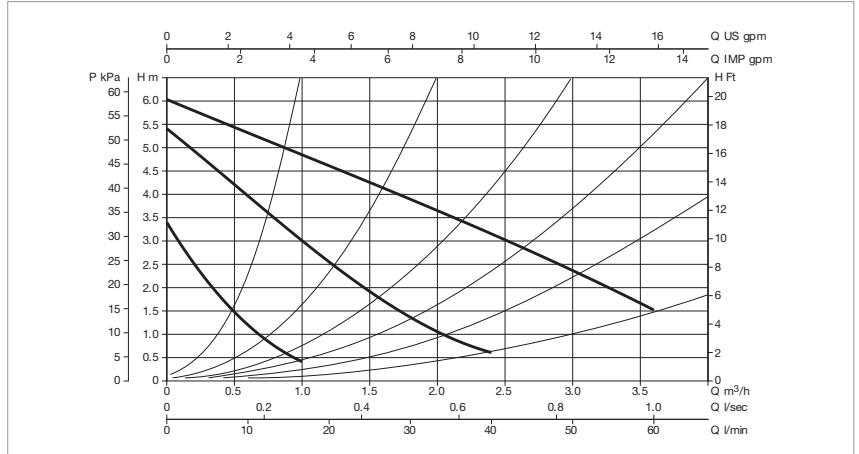
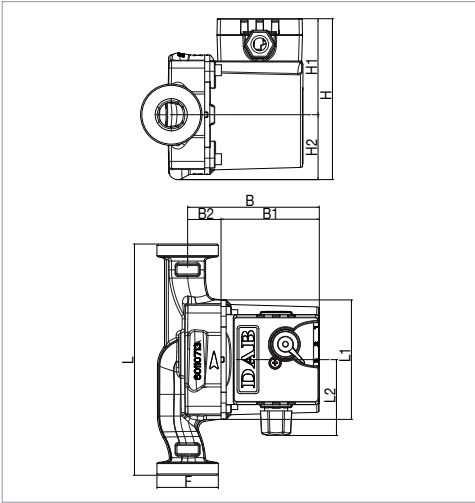

The performance curves are based on kinematic viscosity values = 1 mm²/s and density equal to 1000 kg/m³. Curve tolerance according to ISO 9906.

MODEL	CENTRE DISTANCE mm	POWER INPUT 50 Hz	UNIONS ON REQUEST		ELECTRICAL DATA						MINIMUM SUCTION PRESSURE	
			STANDARDISED	SPECIAL	SPEED	REV. 1/min	P1 MAX W	In A	CAPACITOR µF Vc		t°	90 °
VA 65/180X	130	1x230V ~	1" 1/4" F	-	3	2310	78	0,34	2	450	m.c.w.	2,5
					2	1532	59	0,26				
					1	880	37	0,17				

MODEL	L	L1	L2	B	B1	B2	H	H1	H2	F	PACKING DIMENSIONS			VOLUME m ³	WEIGHT kg
											L	B	H		
VA 65/180X	180	93	59	102,5	76,5	26	125,5	75	50,5	2"	130	190	150	0,0037	2,9

A / B / D

WET ROTOR CIRCULATORS



TECHNICAL DATA

Operating range: from 1 to 12 m³/h with head up to 11 metres

Pumped liquid temperature range: from -10°C to +110°C

Pumped liquid: clean, free from solids and mineral oils, not viscous, chemically neutral, close to the characteristics of water (max 30% glycol)

Maximum working pressure: 10 bar (1000 kPa)

Protection level: IP 44

Insulation class: F

Cable grommet: PG 11

Installation: with motor axis horizontal

Standard voltage input: single-phase 230 V / 50 Hz
three-phase 400 V / 50 Hz

This product complies with European standard EN 60335-2-51

APPLICATIONS

Pump for hot or cold water circulation in small community central heating and air conditioning systems for both civil and industrial applications, of the closed circuit pressurized or open circuit type.

CONSTRUCTION FEATURES

Pump body in cast iron and motor in die cast aluminium.

Impeller in technopolymer, motor shaft in hardened stainless steel held in graphite bearings lubricated by the pumping medium.

Pump body with threaded ports.

Rotor protective jacket, stator jacket, and closing flange in stainless steel.

The two-pole asynchronous wet rotor motor features three-speed operation.

Integral thermal probe in single-phase version.

MATERIALS

N.	PARTS	MATERIALS
1	PUMP BODY	CAST IRON
4	IMPELLER	TECHNOPOLYMER
7A	MOTOR SHAFT	STAINLESS STEEL
7B	ROTOR	-
8	STATOR	-
9	CAPACITOR	-
10	MOTOR CASING	DIE CAST ALUMINIUM
11	BREATHER PLUG	BRASS
100	TERMINAL BOX	-
127	SEAL RING	ETHYLENE PROPYLENE
128	STATOR JACKET	STAINLESS STEEL
129	ROTOR JACKET	STAINLESS STEEL
130	CLOSING FLANGE	STAINLESS STEEL
131	THRUST RING SUPPORT	ETHYLENE PROPYLENE
132	BUSHINGS	GRAPHITE
133	THRUST RING	CERAMIC

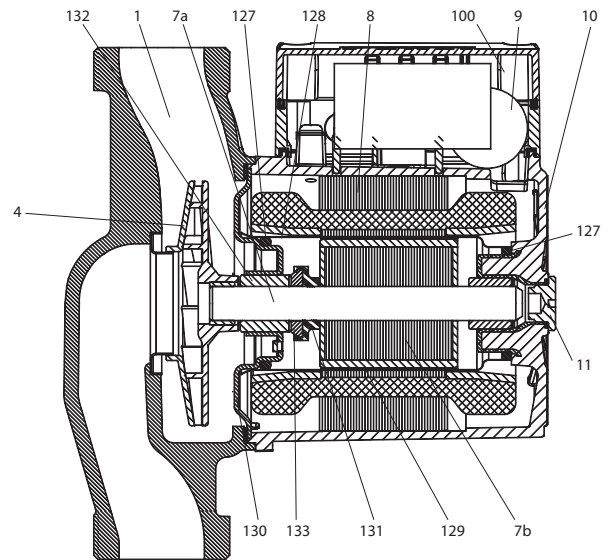

- Legend:
(example)

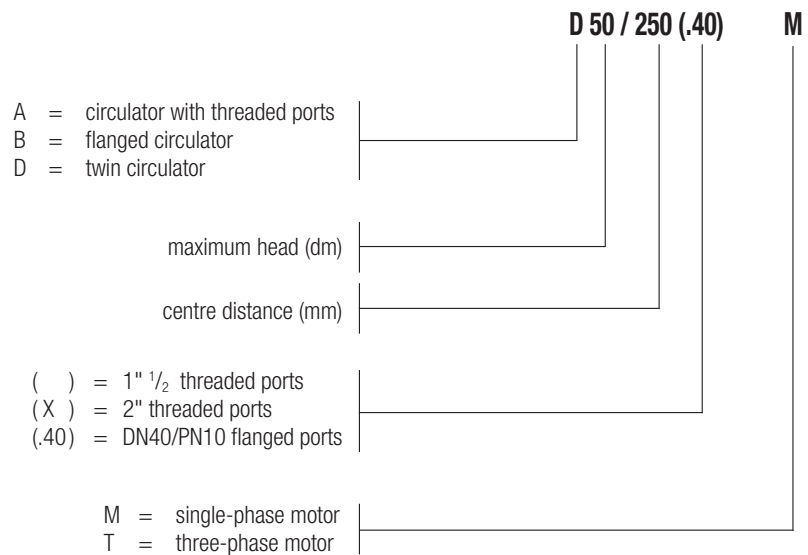

PERFORMANCE RANGE

The performance curves are based on kinematic viscosity values = 1 mm²/s and density equal to 1000 kg/m³. Curve tolerance according to ISO 9906.

GRAPHIC SELECTION TABLE

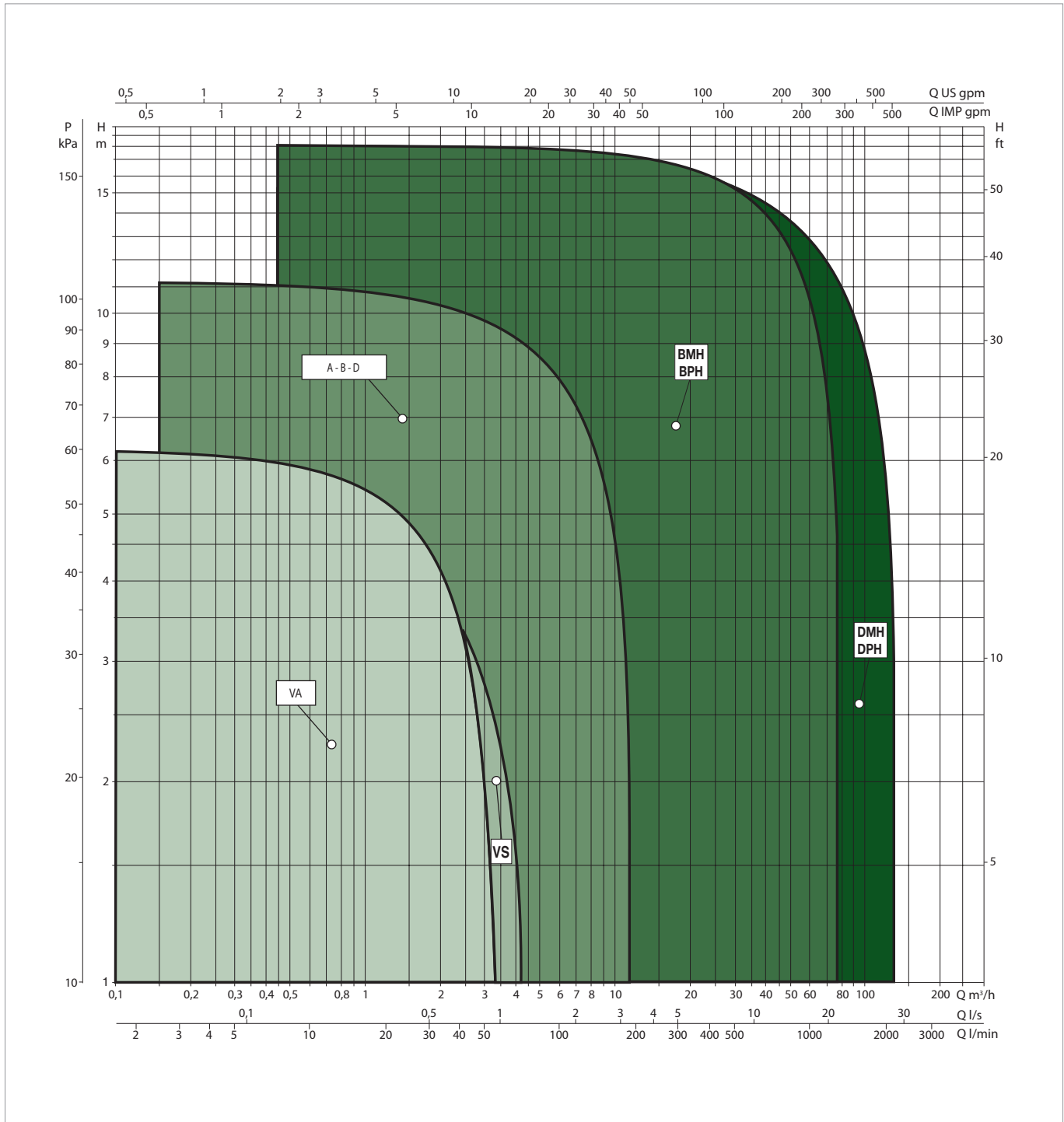

SELECTION TABLE - A SINGLE WITH UNIONS

MODEL	Q=m ³ /h	0	0,6	1,2	1,8	2,4	3	4,2	7,2	12
	Q=l/min	0	10	20	30	40	50	70	120	200
A 50/180 M	H (m)	5,7	5,6	5,4	5,3	5,1	4,8	4,2	2,6	
A 50/180 XM		5,7	5,6	5,4	5,3	5,1	4,8	4,2	2,6	
A 50/180 T		5,6	5,6	5,6	5,5	5,43	5,4	4,9	2,8	
A 50/180 XT		5,9	5,85	5,8	5,6	5,5	5,2	4,6	2,9	
A 56/180 M		6,35	6,3	6,2	6,18	6	5,9	5,5	4,2	1,2
A 56/180 XM		6,35	6,3	6,2	6,18	6	5,9	5,5	4,2	1,2
A 56/180 T		6,42	6,42	6,41	6,4	6,4	6,4	6,1	4,8	
A 56/180 XT		6,4	6,3	6,2	6,1	6	5,9	5,7	4,4	
A 80/180 M		8,25	8	7,6	7,4	7,2	6,9	6,3	3,8	
A 80/180 XM		8,25	8	7,6	7,4	7,2	6,9	6,3	3,8	
A 80/180 T		8,2	7,9	7,6	7,3	7	6,8	6,1	3,7	
A 80/180 XT		8,2	7,9	7,6	7,3	7	6,8	6,1	3,7	
A 110/180 M		11,3	11	10,8	10,5	10	9,8	8,9	6,7	
A 110/180 XM		11,3	11	10,8	10,5	10	9,8	9,2	7	1,7
A 110/180 T		11,3	11	10,8	10,5	10	9,8	8,9	6,6	
A 110/180 XT		11,3	11	10,8	10,5	10	9,8	9,2	7	1,6

SELECTION TABLE - B SINGLE WITH FLANGES

MODEL	Q=m ³ /h	0	0,6	1,2	1,8	2,4	3	4,2	7,2	12
	Q=l/min	0	10	20	30	40	50	70	120	200
B 50/250.40 M	H (m)	5,7	5,6	5,4	5,3	5,1	4,8	4,2	2,6	
B 50/250.40 T		5,9	5,85	5,8	5,6	5,5	5,2	4,6	2,9	
B 56/250.40 M		6,35	6,3	6,2	6,18	6	5,9	5,5	4,2	1,2
B 56/250.40 T		6,4	6,3	6,2	6,1	6	5,9	5,7	4,4	
B 80/250.40 M		8,25	8	7,6	7,4	7,2	6,9	6	3,8	
B 80/250.40 T		8,2	7,9	7,6	7,3	7	6,8	6,1	3,7	
B 110/250.40 M		11,3	11	10,8	10,5	10	9,8	9,2	7	1,7
B 110/250.40 T		11,3	11	10,8	10,5	10	9,8	9,2	7	1,6

SELECTION TABLE - D TWIN WITH FLANGES

MODEL	Q=m ³ /h	0	0,6	1,2	1,8	2,4	3	4,2	7,2	12
	Q=l/min	0	10	20	30	40	50	70	120	200
D 50/250.40 M	H (m)	5,7	5,6	5,4	5,3	5,1	4,8	4,2	2,6	
D 50/250.40 T		5,9	5,85	5,8	5,6	5,5	5,2	4,6	2,9	
D 56/250.40 M		6,35	6,3	6,2	6,18	6	5,9	5,5	4,2	1,2
D 56/250.40 T		5,9	5,85	5,8	5,6	5,5	5,2	4,6	2,9	
D 80/250.40 M		8,25	8	7,6	7,4	7,2	6,9	6,3	3,8	
D 80/250.40 T		8,2	7,9	7,6	7,3	7	6,8	6,1	3,7	
D 110/250.40 M		11,3	11	10,8	10,5	10	9,8	9,2	7	1,7
D 110/250.40 T		11,3	11	10,8	10,5	10	9,8	9,2	7	1,6

A 50/180 M - WET ROTOR CIRCULATORS

Pumped liquid temperature range: from -10 °C to +110 °C - Maximum operating pressure: 10 bar (1000 kPa)

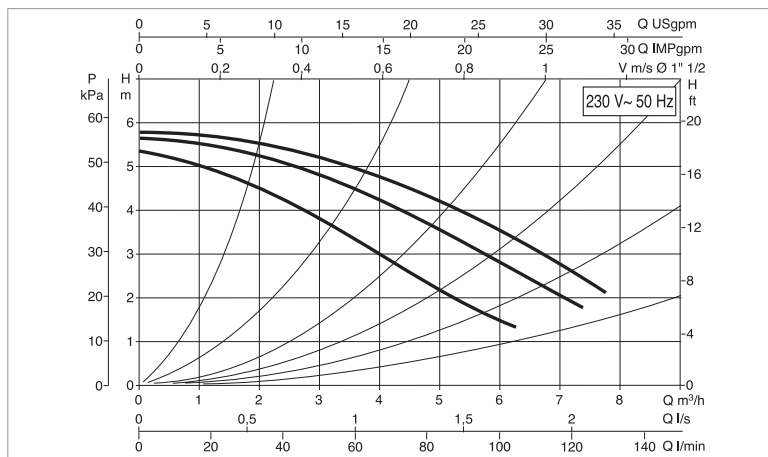
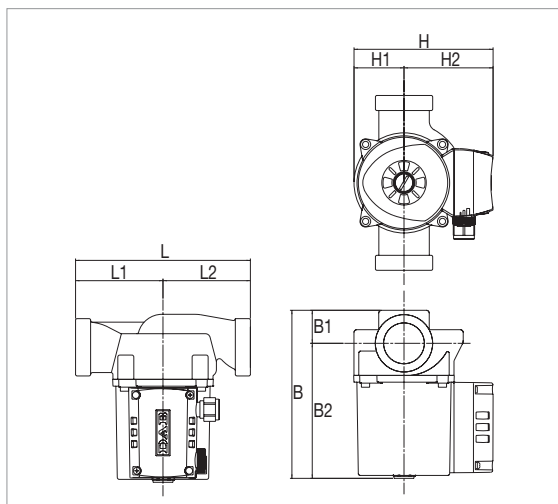

The performance curves are based on kinematic viscosity values = 1 mm²/s and density equal to 1000 kg/m³. Curve tolerance according to ISO 9906.

MODEL	CENTRE DISTANCE mm	POWER INPUT 50 Hz	UNIONS ON REQUEST	ELECTRICAL DATA						MINIMUM SUCTION PRESSURE	
				SPEED	REV. 1/min	P1 MAX W	In A	CAPACITOR		t°	90°
								µF	Vc		
A 50/180 M	180	1x230 V ~	1"	3	2766	195	0,95	4	400	m.c.w.	1,5
				2	2616	194	0,95				
				1	2215	180	0,85				

MODEL	L	L1	L2	B	B1	B2	H	H1	H2	F	PACKING DIMENSIONS			VOLUME m³	WEIGHT kg
											L	B	H		
A 50/180 M	180	90	90	173	34	139	143	52	92	1" ½ 1" ½ 1" ½	206	170	180	0,0063	5,3

A 50/180 XM - WET ROTOR CIRCULATORS

Pumped liquid temperature range: from -10 °C to +110 °C - Maximum operating pressure: 10 bar (1000 kPa)

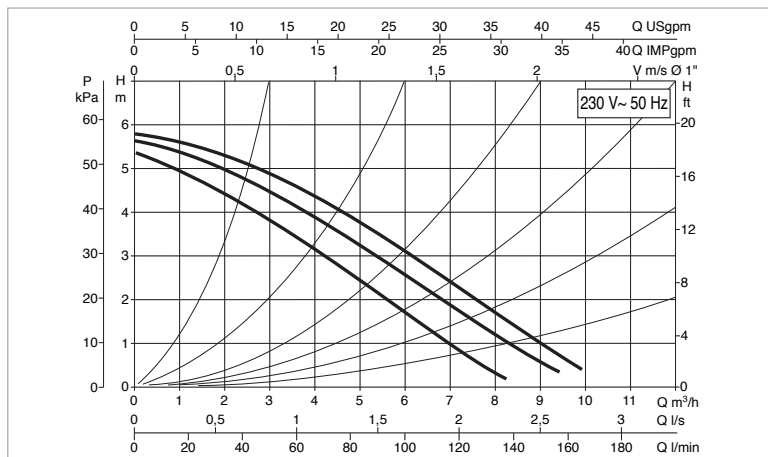
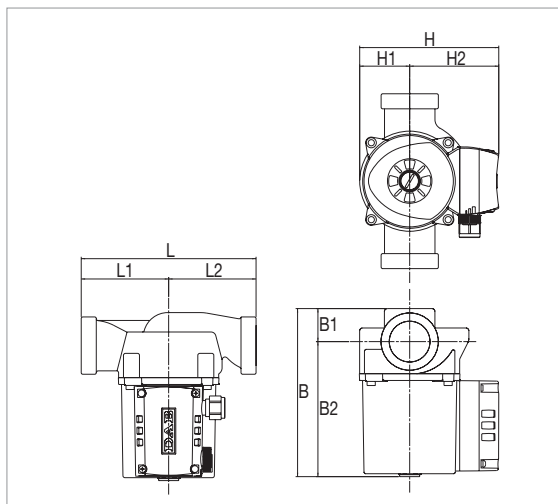

The performance curves are based on kinematic viscosity values = 1 mm²/s and density equal to 1000 kg/m³. Curve tolerance according to ISO 9906.

MODEL	CENTRE DISTANCE mm	POWER INPUT 50 Hz	UNIONS ON REQUEST	ELECTRICAL DATA						MINIMUM SUCTION PRESSURE	
				SPEED	REV. 1/min	P1 MAX W	In A	CAPACITOR		t°	90°
								µF	Vc		
A 50/180 XM	180	1x230 V ~	1 ¼"	3	2791	184	0,92	4	400	m.c.w.	1,5
				2	2651	189	0,92				
				1	2297	168	0,80				

MODEL	L	L1	L2	B	B1	B2	H	H1	H2	F	PACKING DIMENSIONS			VOLUME m³	WEIGHT kg
											L	B	H		
A 50/180 XM	180	90	90	173	34	139	143	52	92	2" G	206	170	180	0,0063	5,3

A 50/180 T - WET ROTOR CIRCULATORS

Pumped liquid temperature range: from -10 °C to +110 °C - Maximum operating pressure: 10 bar (1000 kPa)

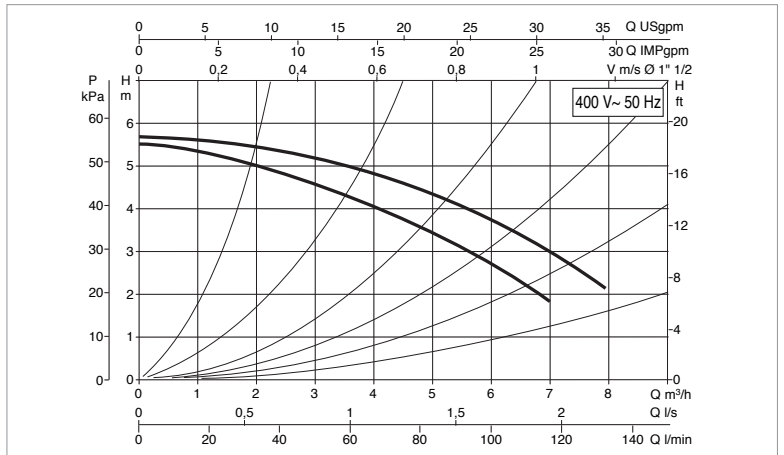
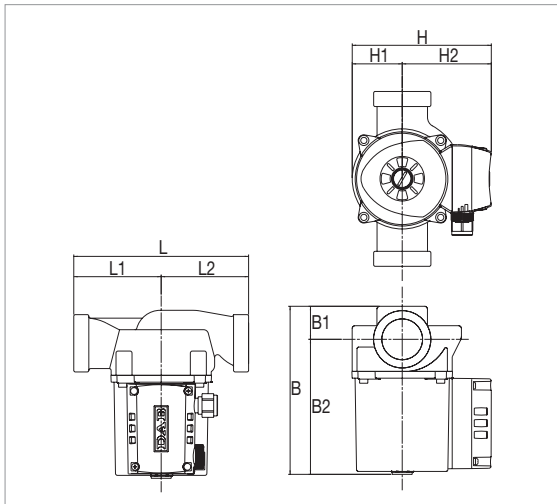

The performance curves are based on kinematic viscosity values = 1 mm²/s and density equal to 1000 kg/m³. Curve tolerance according to ISO 9906.

MODEL	CENTRE DISTANCE mm	POWER INPUT 50 Hz	UNIONS ON REQUEST	ELECTRICAL DATA						MINIMUM SUCTION PRESSURE	
				SPEED	REV. 1/min	P1 MAX W	In A	CAPACITOR		t°	90 °
A 50/180 T	180	3x400 V ~	1"	2	2827	197	0,52	-	-	m.c.w.	1,5
				1	2502	139	0,25	-	-		

MODEL	L	L1	L2	B	B1	B2	H	H1	H2	F	PACKING DIMENSIONS			VOLUME m ³	WEIGHT kg
											L	B	H		
A 50/180 T	180	90	90	173	34	139	143	52	92	1" ½ 1" ½ 1" ½	206	170	180	0,0063	5,3

A 50/180 XT - WET ROTOR CIRCULATORS

Pumped liquid temperature range: from -10 °C to +110 °C - Maximum operating pressure: 10 bar (1000 kPa)

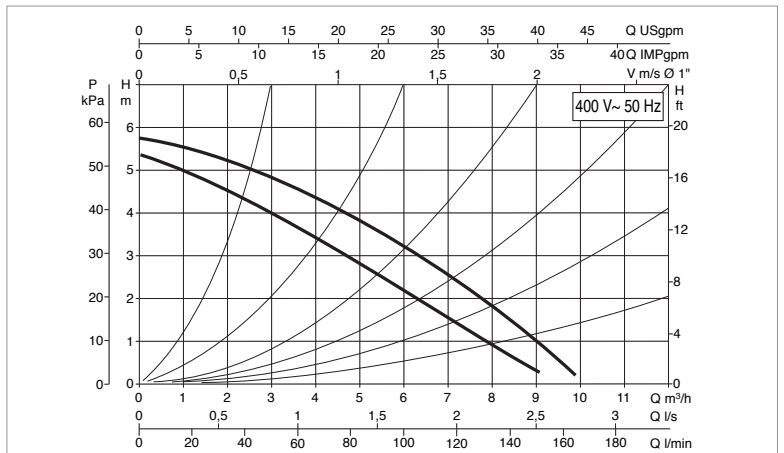
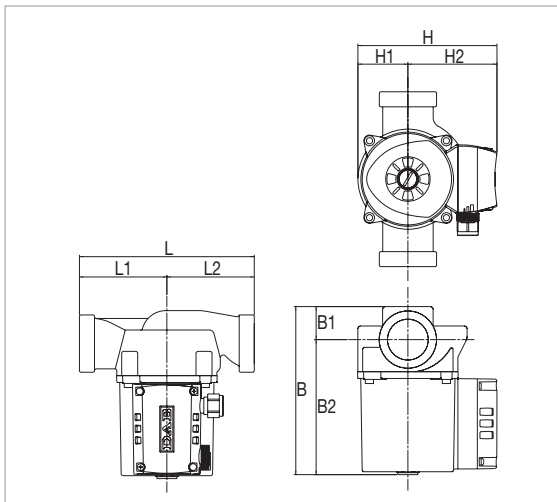

The performance curves are based on kinematic viscosity values = 1 mm²/s and density equal to 1000 kg/m³. Curve tolerance according to ISO 9906.

MODEL	CENTRE DISTANCE mm	POWER INPUT 50 Hz	UNIONS ON REQUEST	ELECTRICAL DATA						MINIMUM SUCTION PRESSURE	
				SPEED	REV. 1/min	P1 MAX W	In A	CAPACITOR		t°	90 °
A 50/180 XT	180	3x400 V ~	1" ¼	2	2838	201	0,50	-	-	m.c.w.	1,5
				1	2520	129	0,23	-	-		

MODEL	L	L1	L2	B	B1	B2	H	H1	H2	F	PACKING DIMENSIONS			VOLUME m ³	WEIGHT kg
											L	B	H		
A 50/180 XT	180	90	90	173	34	139	143	52	92	2" G	206	170	180	0,0063	5,2

A 56/180 M - WET ROTOR CIRCULATORS

Pumped liquid temperature range: from -10 °C to +110 °C - Maximum operating pressure: 10 bar (1000 kPa)

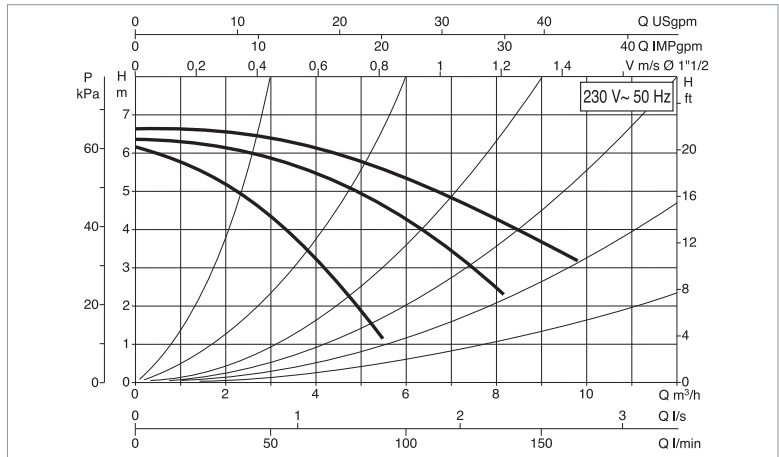
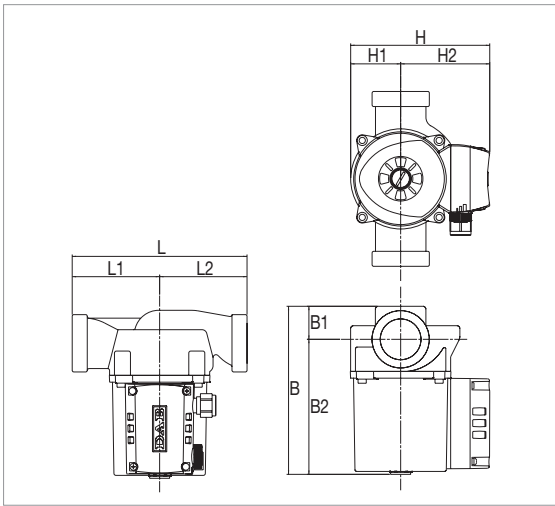

The performance curves are based on kinematic viscosity values = 1 mm²/s and density equal to 1000 kg/m³. Curve tolerance according to ISO 9906.

MODEL	CENTRE DISTANCE mm	POWER INPUT 50 Hz	UNIONS ON REQUEST	ELECTRICAL DATA						MINIMUM SUCTION PRESSURE	
				SPEED	REV. 1/min	P1 MAX W	In A	CAPACITOR		t°	90 °
								µF	Vc		
A 56/180 M	180	1x230 V ~	1"	3	2636	282	1,23	7	400	m.c.w.	1,5
				2	2226	287	1,30				
				1	1485	228	1,06				

MODEL	L	L1	L2	B	B1	B2	H	H1	H2	F	PACKING DIMENSIONS			VOLUME m³	WEIGHT kg
											L	B	H		
A 56/180 M	180	90	90	173	34	139	143	52	92	1" ½1" ½1" ½	206	170	180	0,0063	5,3

A 56/180 XM - WET ROTOR CIRCULATORS

Pumped liquid temperature range: from -10 °C to +110 °C - Maximum operating pressure: 10 bar (1000 kPa)

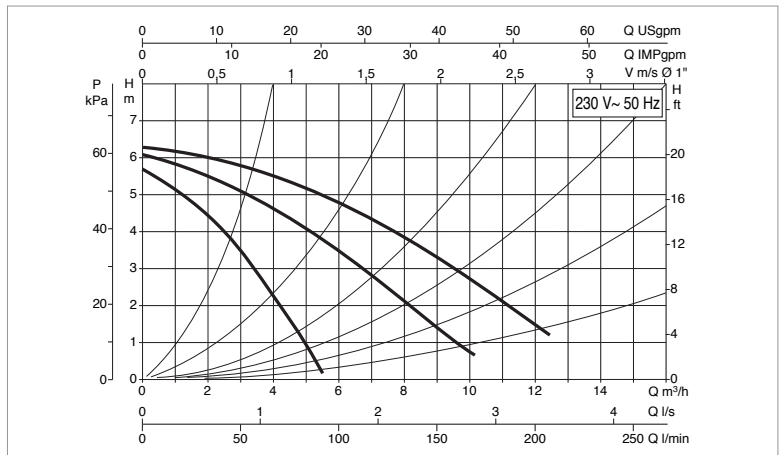
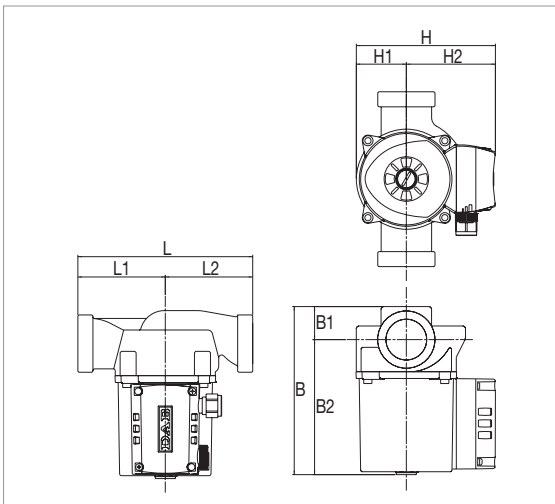

The performance curves are based on kinematic viscosity values = 1 mm²/s and density equal to 1000 kg/m³. Curve tolerance according to ISO 9906.

MODEL	CENTRE DISTANCE mm	POWER INPUT 50 Hz	UNIONS ON REQUEST	ELECTRICAL DATA						MINIMUM SUCTION PRESSURE	
				SPEED	REV. 1/min	P1 MAX W	In A	CAPACITOR		t°	90 °
								µF	Vc		
A 56/180 XM	180	1x230 V ~	1" ¼	3	2658	271	1,18	7	400	m.c.w.	1,5
				2	2117	294	1,32				
				1	1394	224	1,00				

MODEL	L	L1	L2	B	B1	B2	H	H1	H2	F	PACKING DIMENSIONS			VOLUME m³	WEIGHT kg
											L	B	H		
A 56/180 XM	180	90	90	173	34	139	143	52	92	2" G	206	170	180	0,0063	5,3

A 56/180 T - WET ROTOR CIRCULATORS

Pumped liquid temperature range: from -10 °C to +110 °C - Maximum operating pressure: 10 bar (1000 kPa)

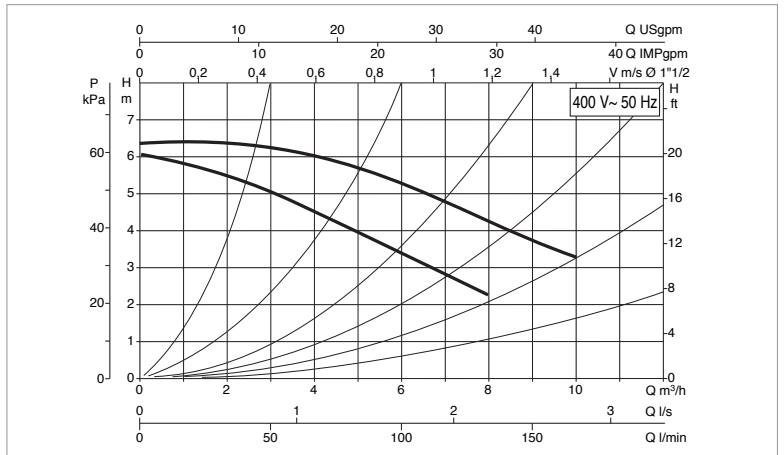
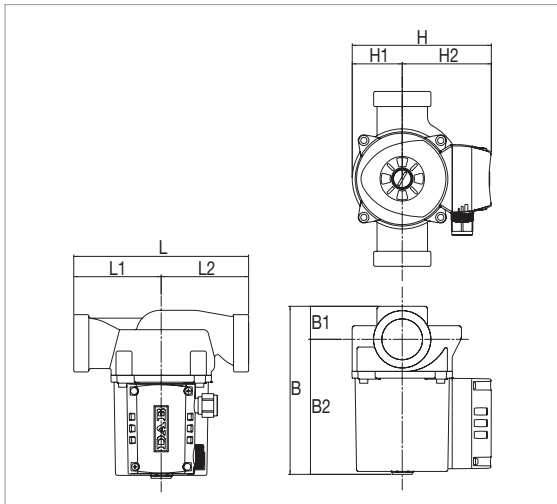

The performance curves are based on kinematic viscosity values = 1 mm²/s and density equal to 1000 kg/m³. Curve tolerance according to ISO 9906.

MODEL	CENTRE DISTANCE mm	POWER INPUT 50 Hz	UNIONS ON REQUEST	ELECTRICAL DATA						MINIMUM SUCTION PRESSURE	
				SPEED	REV. 1/min	P1 MAX W	In A	CAPACITOR		t°	90°
								µF	Vc		
A 56/180 T	180	3x400 V ~	1"	2	2704	294	0,60	-	-	m.c.w.	1,5
				1	2178	200	0,33	-	-		

MODEL	L	L1	L2	B	B1	B2	H	H1	H2	F	PACKING DIMENSIONS			VOLUME m ³	WEIGHT kg
											L	B	H		
A 56/180 T	180	90	90	173	34	139	143	52	92	1" ½ 1" ½ 1" ½	206	170	180	0,0063	5,3

A 56/180 XT - WET ROTOR CIRCULATORS

Pumped liquid temperature range: from -10 °C to +110 °C - Maximum operating pressure: 10 bar (1000 kPa)

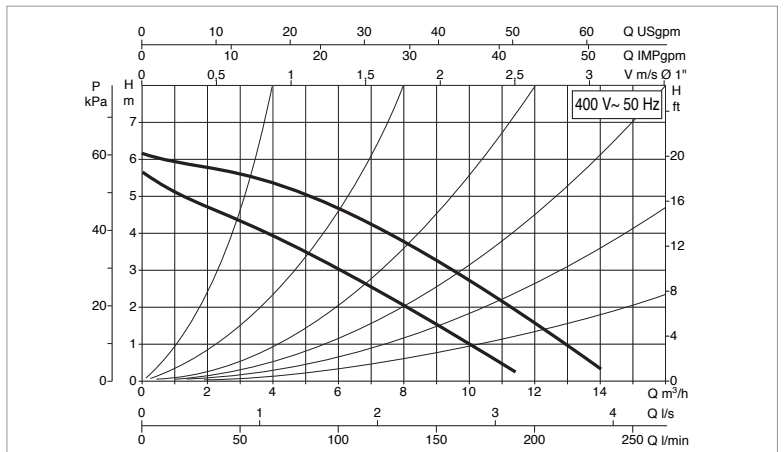
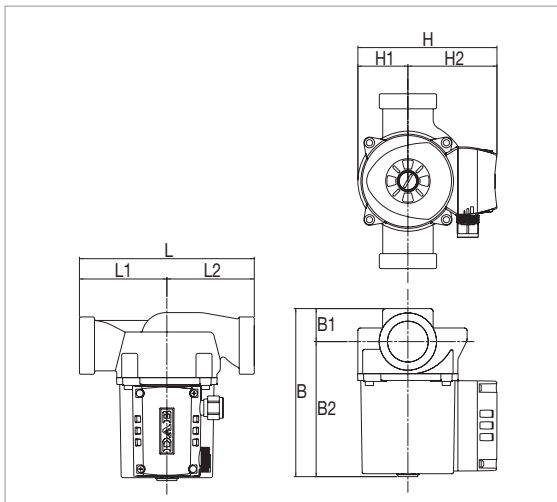

The performance curves are based on kinematic viscosity values = 1 mm²/s and density equal to 1000 kg/m³. Curve tolerance according to ISO 9906.

MODEL	CENTRE DISTANCE mm	POWER INPUT 50 Hz	UNIONS ON REQUEST	ELECTRICAL DATA						MINIMUM SUCTION PRESSURE	
				SPEED	REV. 1/min	P1 MAX W	In A	CAPACITOR		t°	90°
								µF	Vc		
A 56/180 XT	180	3x400 V ~	1" ¼	2	2708	291	0,60	-	-	m.c.w.	1,5
				1	2178	200	0,32	-	-		

MODEL	L	L1	L2	B	B1	B2	H	H1	H2	F	PACKING DIMENSIONS			VOLUME m ³	WEIGHT kg
											L	B	H		
A 56/180 XT	180	90	90	173	34	139	143	52	92	2" G	206	170	180	0,0063	5,3

A 80/180 M - WET ROTOR CIRCULATORS

Pumped liquid temperature range: from -10 °C to +110 °C - Maximum operating pressure: 10 bar (1000 kPa)

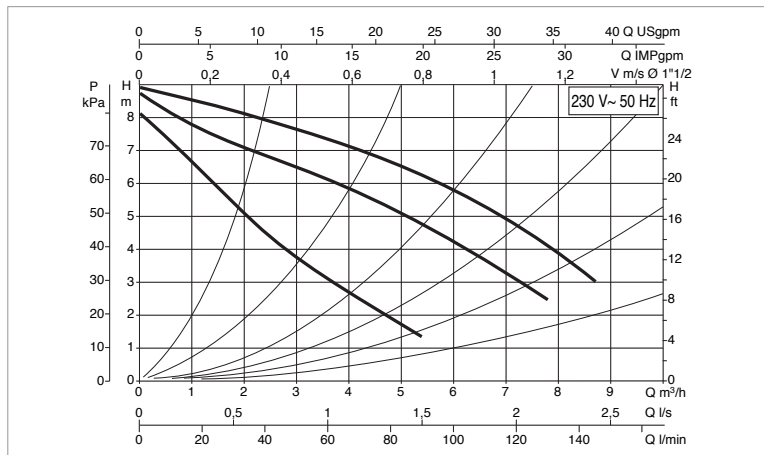
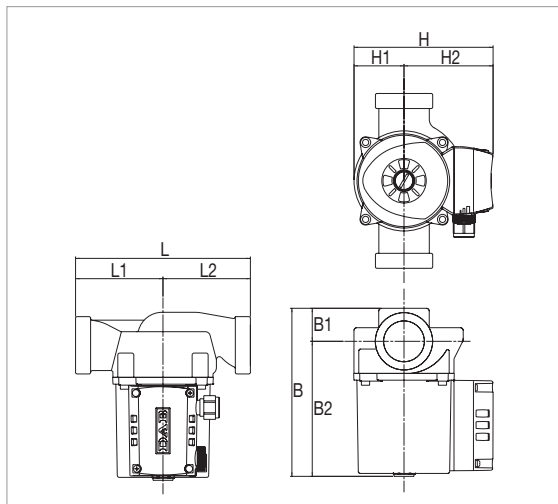

The performance curves are based on kinematic viscosity values = 1 mm²/s and density equal to 1000 kg/m³. Curve tolerance according to ISO 9906.

MODEL	CENTRE DISTANCE mm	POWER INPUT 50 Hz	UNIONS ON REQUEST	ELECTRICAL DATA						MINIMUM SUCTION PRESSURE	
				SPEED	REV. 1/min	P1 MAX W	In A	CAPACITOR		t°	90°
								µF	Vc		
A 80/180 M	180	1x230 V ~	1"	3	2674	264	1,15	7	400	m.c.w.	2,5
				2	2356	262	1,20				
				1	1615	223	1,00				

MODEL	L	L1	L2	B	B1	B2	H	H1	H2	F	PACKING DIMENSIONS			VOLUME m³	WEIGHT kg
											L	B	H		
A 80/180 M	180	90	90	173	34	139	143	52	92	1" ½ 1" ½ 1" ½	206	170	180	0,0063	5,3

A 80/180 XM - WET ROTOR CIRCULATORS

Pumped liquid temperature range: from -10 °C to +110 °C - Maximum operating pressure: 10 bar (1000 kPa)

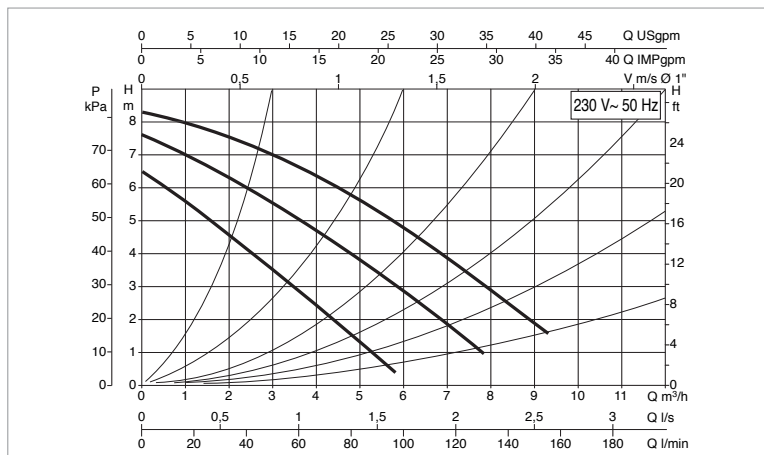
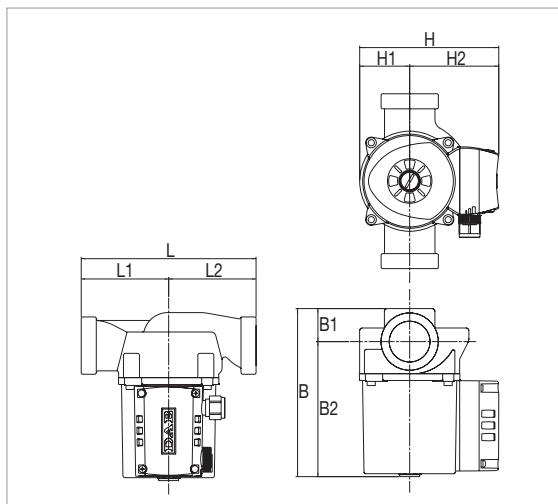

The performance curves are based on kinematic viscosity values = 1 mm²/s and density equal to 1000 kg/m³. Curve tolerance according to ISO 9906.

MODEL	CENTRE DISTANCE mm	POWER INPUT 50 Hz	UNIONS ON REQUEST	ELECTRICAL DATA						MINIMUM SUCTION PRESSURE	
				SPEED	REV. 1/min	P1 MAX W	In A	CAPACITOR		t°	90°
								µF	Vc		
A 80/180 XM	180	1x230 V ~	1" ¼	3	2683	256	1,12	7	400	m.c.w.	2,5
				2	2374	260	1,17				
				1	1688	218	1,00				

MODEL	L	L1	L2	B	B1	B2	H	H1	H2	F	PACKING DIMENSIONS			VOLUME m³	WEIGHT kg
											L	B	H		
A 80/180 XM	180	90	90	173	34	139	143	52	92	2" G	206	170	180	0,0063	5,3

A 80/180 T - WET ROTOR CIRCULATORS

Pumped liquid temperature range: from -10 °C to +110 °C - Maximum operating pressure: 10 bar (1000 kPa)

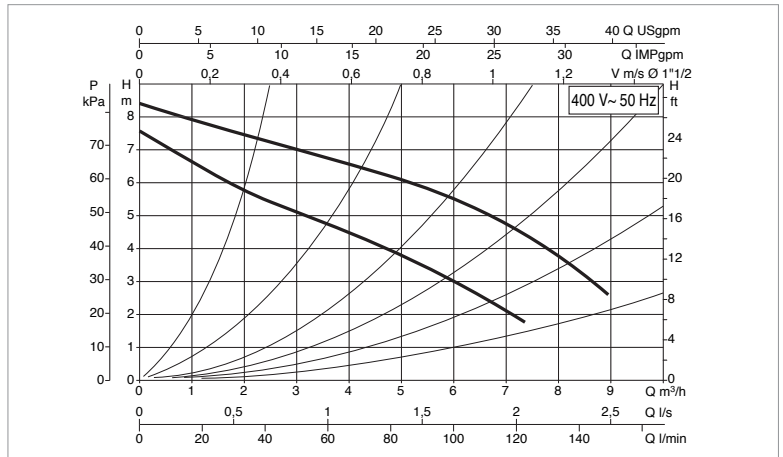
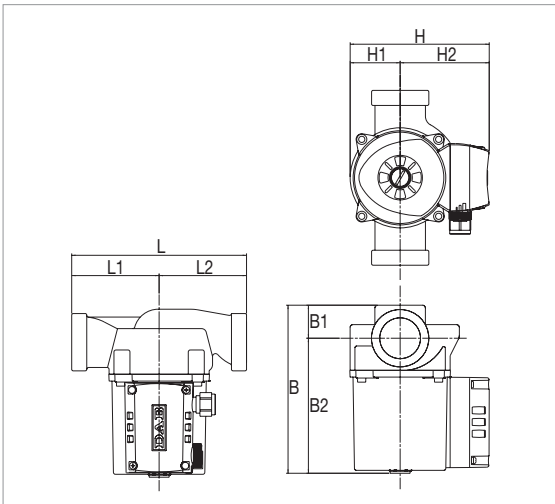

The performance curves are based on kinematic viscosity values = 1 mm²/s and density equal to 1000 kg/m³. Curve tolerance according to ISO 9906.

MODEL	CENTRE DISTANCE mm	POWER INPUT 50 Hz	UNIONS ON REQUEST	ELECTRICAL DATA						MINIMUM SUCTION PRESSURE	
				SPEED	REV. 1/min	P1 MAX W	In A	CAPACITOR		t°	90°
A 80/180 T	180	3x400 V ~	1"	2	2724	271	0,57	-	-	m.c.w.	2,5
				1	2226	187	0,31				

MODEL	L	L1	L2	B	B1	B2	H	H1	H2	F	PACKING DIMENSIONS			VOLUME m ³	WEIGHT kg
											L	B	H		
A 80/180 T	180	90	90	173	34	139	143	52	92	1" ½ 1" ½ 1" ½	206	170	180	0,0063	5,3

A 80/180 XT - WET ROTOR CIRCULATORS

Pumped liquid temperature range: from -10 °C to +110 °C - Maximum operating pressure: 10 bar (1000 kPa)

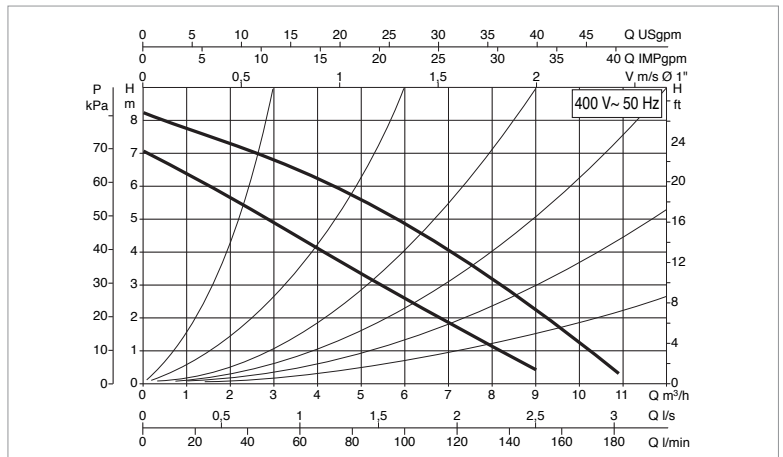
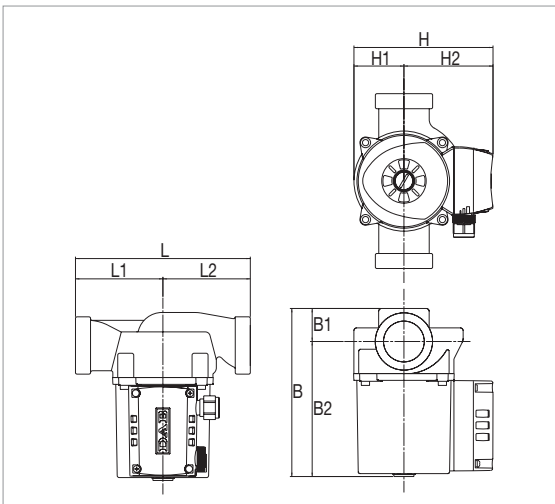

The performance curves are based on kinematic viscosity values = 1 mm²/s and density equal to 1000 kg/m³. Curve tolerance according to ISO 9906.

MODEL	CENTRE DISTANCE mm	POWER INPUT 50 Hz	UNIONS ON REQUEST	ELECTRICAL DATA						MINIMUM SUCTION PRESSURE	
				SPEED	REV. 1/min	P1 MAX W	In A	CAPACITOR		t°	90°
A 80/180 XT	180	3x400 V ~	1"	2	2727	272	0,57	-	-	m.c.w.	2,5
				1	2227	186	0,30				

MODEL	L	L1	L2	B	B1	B2	H	H1	H2	F	PACKING DIMENSIONS			VOLUME m ³	WEIGHT kg
											L	B	H		
A 80/180 XT	180	90	90	173	34	139	143	52	92	2" G	206	170	180	0,0063	5,3

A 110/180 M - WET ROTOR CIRCULATORS

Pumped liquid temperature range: from -10 °C to +110 °C - Maximum operating pressure: 10 bar (1000 kPa)

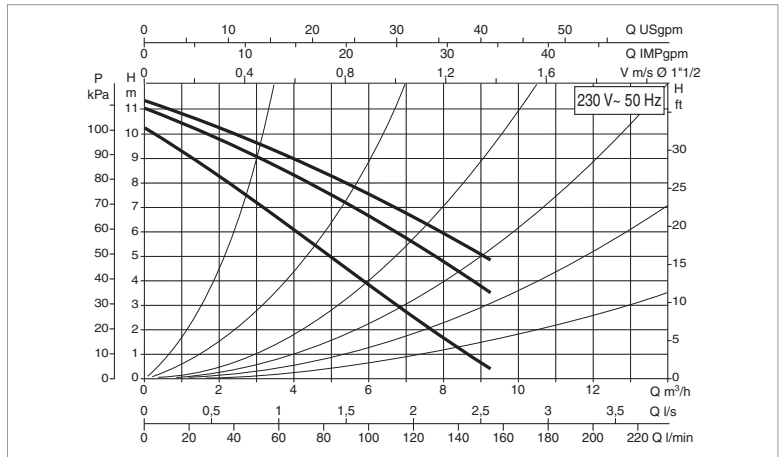
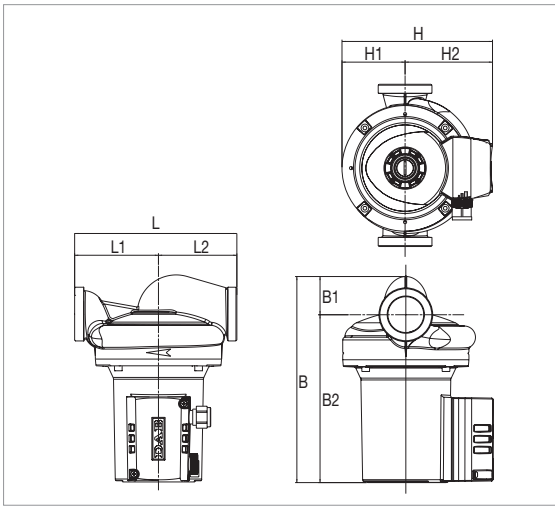

The performance curves are based on kinematic viscosity values = 1 mm²/s and density equal to 1000 kg/m³. Curve tolerance according to ISO 9906.

MODEL	CENTRE DISTANCE mm	POWER INPUT 50 Hz	UNIONS ON REQUEST	ELECTRICAL DATA						MINIMUM SUCTION PRESSURE	
				SPEED	REV. 1/min	P1 MAX W	In A	CAPACITOR		t°	90 °
A 110/180 M	180	1x230 V ~	2" G	3	2746	410	1,6	12	450	m.c.w.	2,5
				2	2552	393	1,8				
				1	2052	361	1,7				

MODEL	L	L1	L2	B	B1	B2	H	H1	H2	F	PACKING DIMENSIONS			VOLUME m³	WEIGHT kg
											L	B	H		
A 110/180 M	180	93	87	229	42	186	167	70	97	1" ½ G1" ½ G	237	200	272	0,013	5,3

A 110/180 XM - WET ROTOR CIRCULATORS

Pumped liquid temperature range: from -10 °C to +110 °C - Maximum operating pressure: 10 bar (1000 kPa)

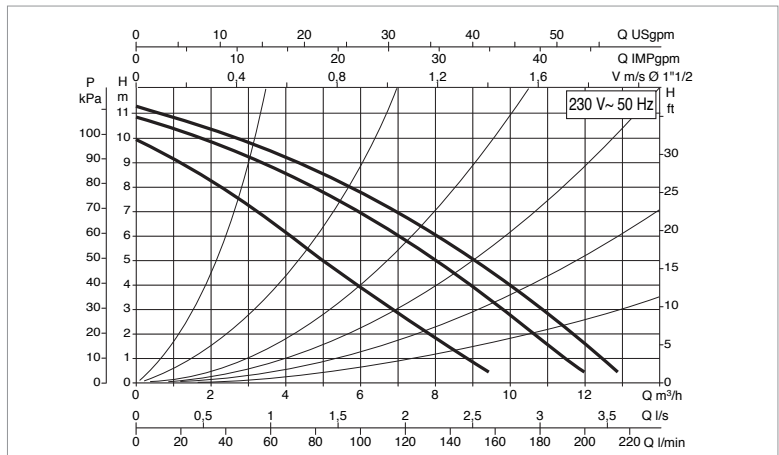
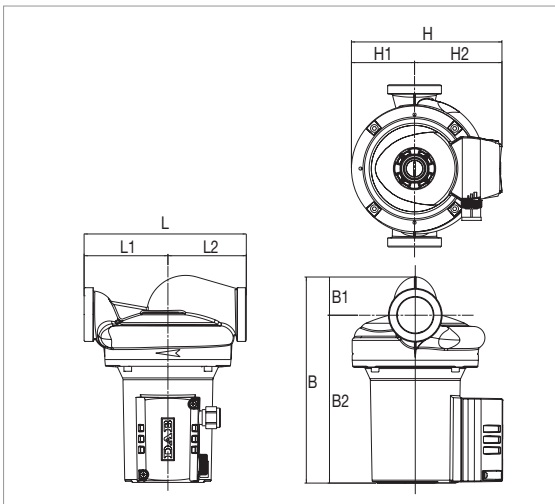

The performance curves are based on kinematic viscosity values = 1 mm²/s and density equal to 1000 kg/m³. Curve tolerance according to ISO 9906.

MODEL	CENTRE DISTANCE mm	POWER INPUT 50 Hz	UNIONS ON REQUEST	ELECTRICAL DATA						MINIMUM SUCTION PRESSURE	
				SPEED	REV. 1/min	P1 MAX W	In A	CAPACITOR		t°	90 °
A 110/180 XM	180	1x230 V ~	1" ¼	3	2746	410	1,6	12	450	m.c.w.	2,5
				2	2552	393	1,8				
				1	2052	361	1,7				

MODEL	L	L1	L2	B	B1	B2	H	H1	H2	F	PACKING DIMENSIONS			VOLUME m³	WEIGHT kg
											L	B	H		
A 110/180 XM	180	93	87	229	42	186	167	70	97	2" G	237	200	272	0,013	5,3

A 110/180 T - WET ROTOR CIRCULATORS

Pumped liquid temperature range: from -10 °C to +110 °C - Maximum operating pressure: 10 bar (1000 kPa)

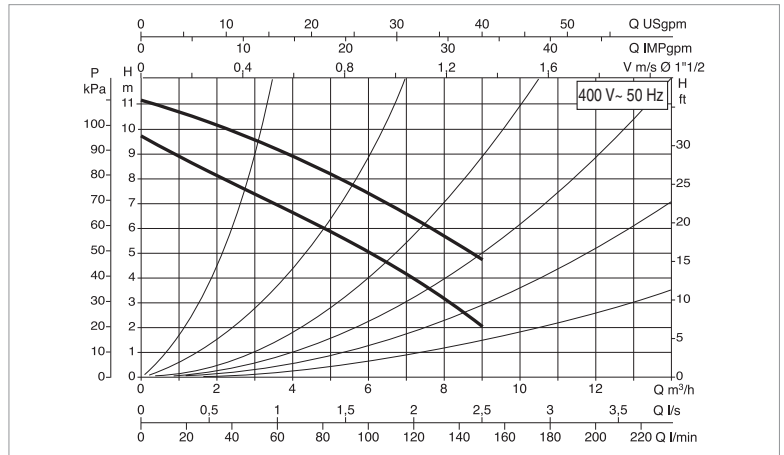
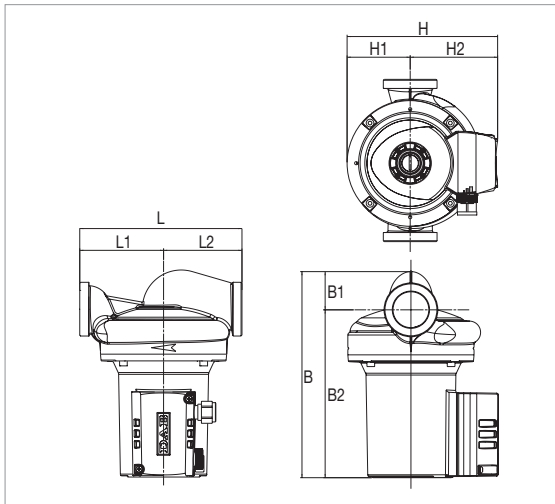

The performance curves are based on kinematic viscosity values = 1 mm²/s and density equal to 1000 kg/m³. Curve tolerance according to ISO 9906.

MODEL	CENTRE DISTANCE mm	POWER INPUT 50 Hz	UNIONS ON REQUEST	ELECTRICAL DATA						MINIMUM SUCTION PRESSURE	
				SPEED	REV. 1/min	P1 MAX W	In A	CAPACITOR		t°	90 °
A 110/180 T	180	3x400 V ~	2" G	2	2753	402	0,87	-	-	m.c.w.	2,5
				1	2338	286	0,48	-	-		

MODEL	L	L1	L2	B	B1	B2	H	H1	H2	F	PACKING DIMENSIONS			VOLUME m³	WEIGHT kg
											L	B	H		
A 110/180 T	180	93	87	229	42	186	163	70	93	1" ½ G1" ½ G	237	200	272	0,013	5,2

A 110/180 XT - WET ROTOR CIRCULATORS

Pumped liquid temperature range: from -10 °C to +110 °C - Maximum operating pressure: 10 bar (1000 kPa)

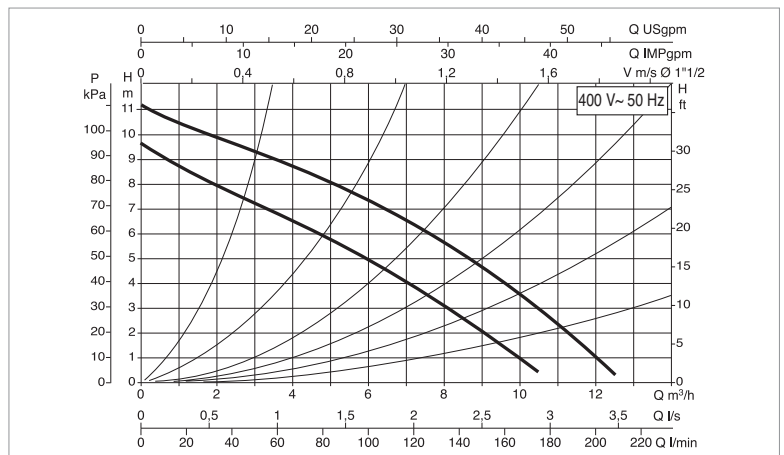
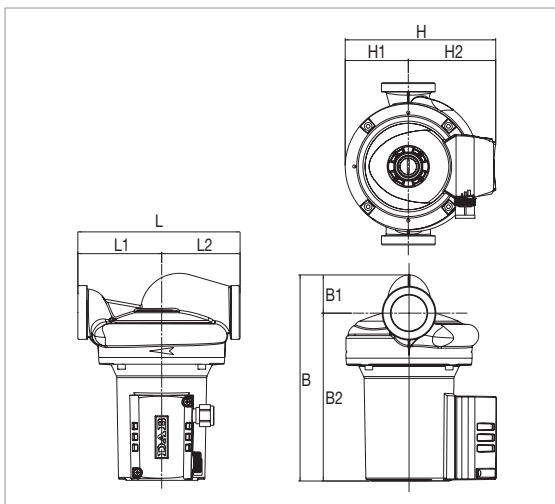

The performance curves are based on kinematic viscosity values = 1 mm²/s and density equal to 1000 kg/m³. Curve tolerance according to ISO 9906.

MODEL	CENTRE DISTANCE mm	POWER INPUT 50 Hz	UNIONS ON REQUEST	ELECTRICAL DATA						MINIMUM SUCTION PRESSURE	
				SPEED	REV. 1/min	P1 MAX W	In A	CAPACITOR		t°	90 °
A 110/180 XT	180	3x400 V ~	2" G	2	2759	403	0,90	-	-	m.c.w.	2,5
				1	2341	289	0,48	-	-		

MODEL	L	L1	L2	B	B1	B2	H	H1	H2	F	PACKING DIMENSIONS			VOLUME m³	WEIGHT kg
											L	B	H		
A 110/180 XT	180	93	87	229	42	186	163	70	93	2" G	237	200	272	0,013	5,2

B 50/250.40 M - WET ROTOR CIRCULATORS

Pumped liquid temperature range: from -10 °C to +110 °C - Maximum operating pressure: 10 bar (1000 kPa)

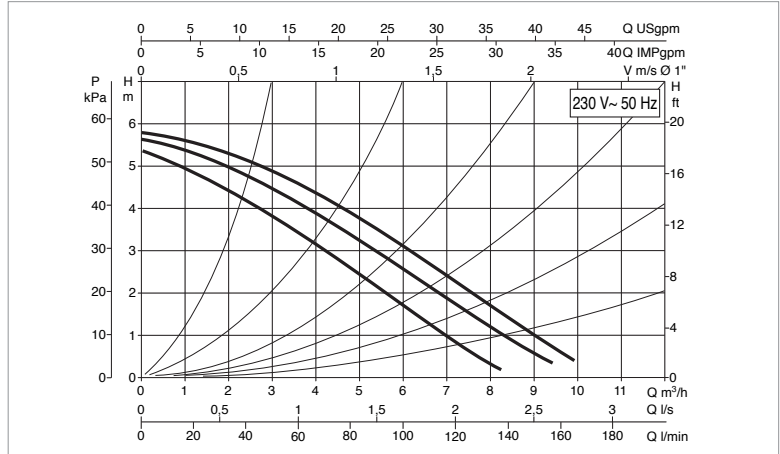
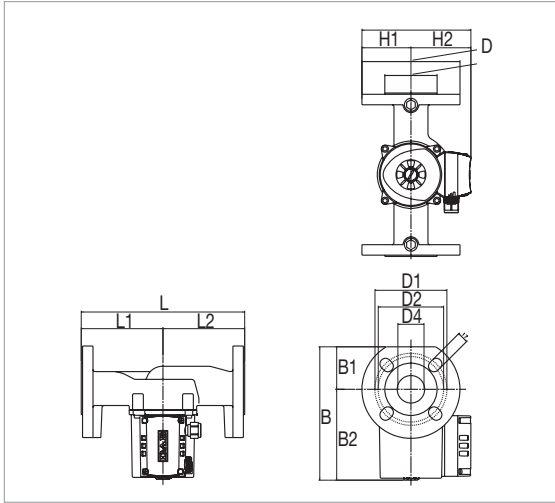

The performance curves are based on kinematic viscosity values = 1 mm²/s and density equal to 1000 kg/m³. Curve tolerance according to ISO 9906.

MODEL	CENTRE DISTANCE mm	POWER INPUT 50 Hz	COUNTERFLANGES ON REQUEST	ELECTRICAL DATA						MINIMUM SUCTION PRESSURE	
				SPEED	REV. 1/min	P1 MAX W	In A	CAPACITOR		t°	90 °
								μF	Vc		
B 50/250.40 M	250	1x230 V ~	DN 40	3	2766	195	0,95	4	400	m.c.w.	1,5
				2	2616	194	0,95				
				1	2215	180	0,85				

MODEL	L	L1	L2	B	B1	B2	D	D1	D2	D3	D4	H	H1	H2	F	PACKING DIMENSIONS			VOLUME m ³	WEIGHT kg
																L	B	H		
B 50/250.40 M	250	125	125	204	65	139	150	110	100	80	40	167	75	92	DN40/PN10	302	202	283	0,017	9,1

B 50/250.40 T - WET ROTOR CIRCULATORS

Pumped liquid temperature range: from -10 °C to +110 °C - Maximum operating pressure: 10 bar (1000 kPa)

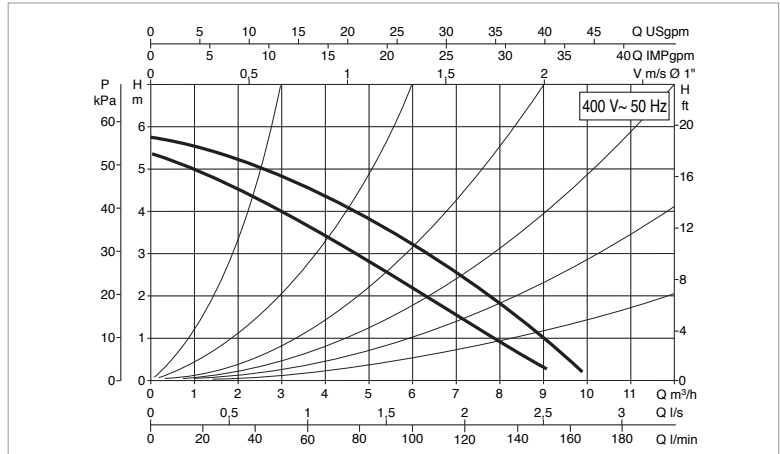
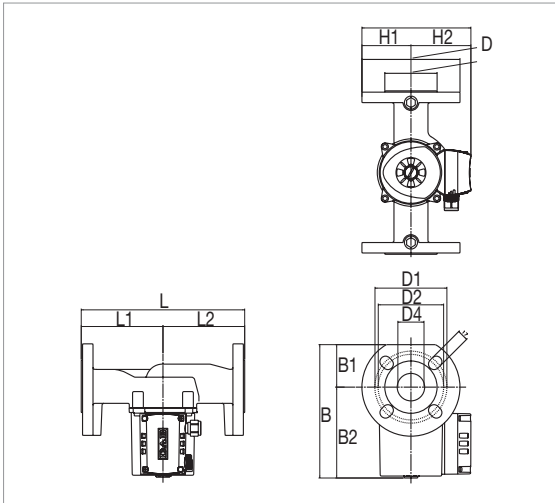

The performance curves are based on kinematic viscosity values = 1 mm²/s and density equal to 1000 kg/m³. Curve tolerance according to ISO 9906.

MODEL	CENTRE DISTANCE mm	POWER INPUT 50 Hz	COUNTERFLANGES ON REQUEST	ELECTRICAL DATA						MINIMUM SUCTION PRESSURE	
				SPEED	REV. 1/min	P1 MAX W	In A	CAPACITOR		t°	90 °
								μF	Vc		
B 50/250.40 T	250	3x400 V ~	DN 40	2	2838	201	0,5	-	-	m.c.w.	1,5
				1	2520	129	0,23				

MODEL	L	L1	L2	B	B1	B2	D	D1	D2	D3	D4	H	H1	H2	F	PACKING DIMENSIONS			VOLUME m ³	WEIGHT kg
																L	B	H		
B 50/250.40 T	250	125	125	204	65	139	150	110	100	80	40	167	75	92	DN40/PN10	302	202	283	0,017	9,3

B 56/250.40 M - WET ROTOR CIRCULATORS

Pumped liquid temperature range: from -10 °C to +110 °C - Maximum operating pressure: 10 bar (1000 kPa)

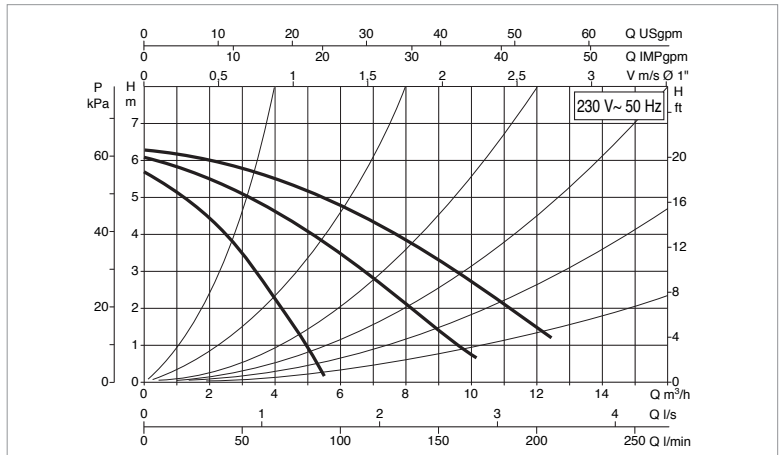
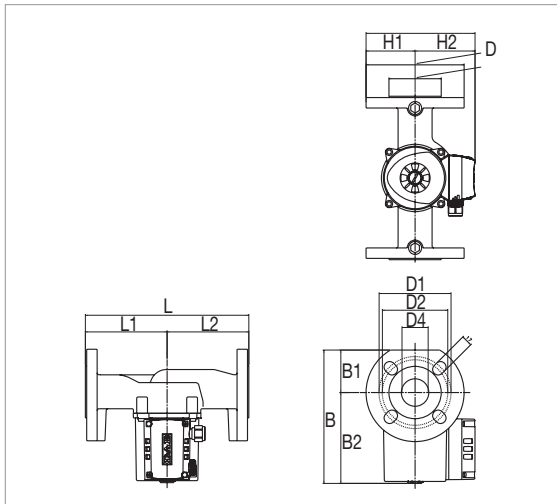

The performance curves are based on kinematic viscosity values = 1 mm²/s and density equal to 1000 kg/m³. Curve tolerance according to ISO 9906.

MODEL	CENTRE DISTANCE mm	POWER INPUT 50 Hz	COUNTERFLANGES ON REQUEST	ELECTRICAL DATA						MINIMUM SUCTION PRESSURE	
				SPEED	REV. 1/min	P1 MAX W	In A	CAPACITOR		t°	90°
B 56/250.40 M	250	1x230 V ~	DN 40	3	2658	271	1,18	7	400	m.c.w.	1,5
				2	2117	294	1,32				
				1	1394	224	1				

MODEL	L	L1	L2	B	B1	B2	D	D1	D2	D3	D4	H	H1	H2	F	PACKING DIMENSIONS			VOLUME m ³	WEIGHT kg
																L	B	H		
B 56/250.40 M	250	125	125	204	65	139	150	110	100	80	40	167	75	92	DN40/PN10	302	202	283	0,017	9,3

B 56/250.40 T - WET ROTOR CIRCULATORS

Pumped liquid temperature range: from -10 °C to +110 °C - Maximum operating pressure: 10 bar (1000 kPa)

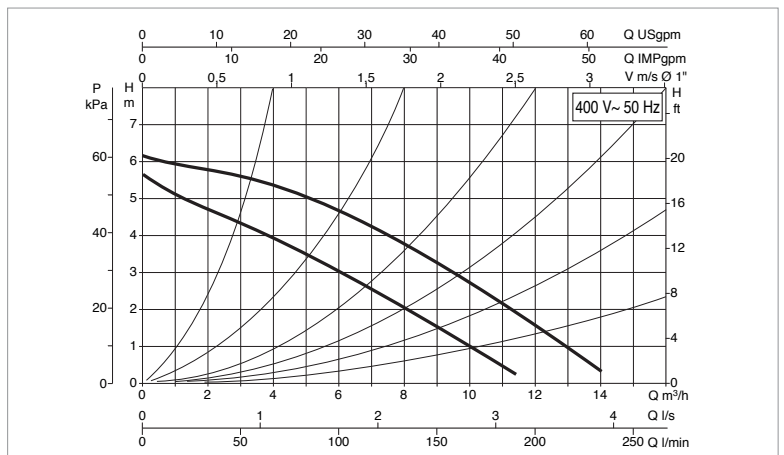
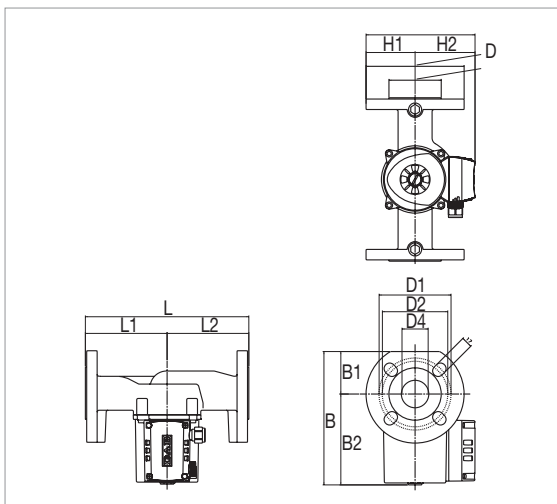

The performance curves are based on kinematic viscosity values = 1 mm²/s and density equal to 1000 kg/m³. Curve tolerance according to ISO 9906.

MODEL	CENTRE DISTANCE mm	POWER INPUT 50 Hz	COUNTERFLANGES ON REQUEST	ELECTRICAL DATA						MINIMUM SUCTION PRESSURE	
				SPEED	REV. 1/min	P1 MAX W	In A	CAPACITOR		t°	90°
B 56/250.40 T	250	3x400 V ~	DN 40	2	2708	291	0,6	-	-	m.c.w.	1,5
				1	2178	200	0,32				

MODEL	L	L1	L2	B	B1	B2	D	D1	D2	D3	D4	H	H1	H2	F	PACKING DIMENSIONS			VOLUME m ³	WEIGHT kg
																L	B	H		
B 56/250.40 T	250	125	125	204	65	139	150	110	100	80	40	167	75	92	DN40/PN10	302	202	283	0,017	9,2

B 80/250.40 M - WET ROTOR CIRCULATORS

Pumped liquid temperature range: from -10 °C to +110 °C - Maximum operating pressure: 10 bar (1000 kPa)

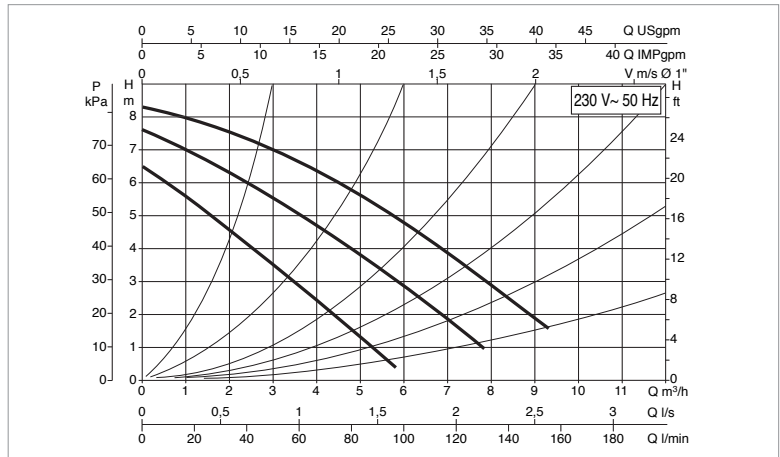
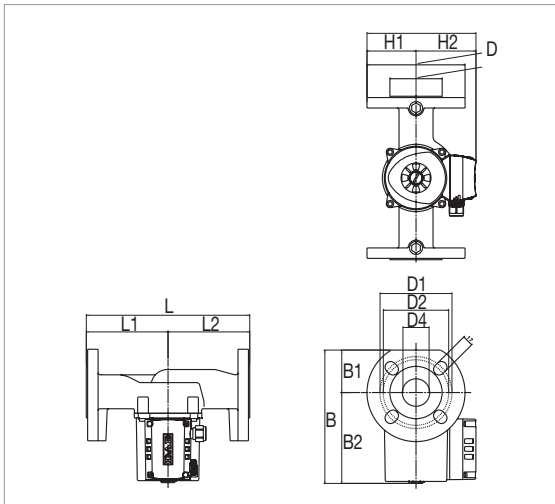

The performance curves are based on kinematic viscosity values = 1 mm²/s and density equal to 1000 kg/m³. Curve tolerance according to ISO 9906.

MODEL	CENTRE DISTANCE mm	POWER INPUT 50 Hz	COUNTERFLANGES ON REQUEST	ELECTRICAL DATA						MINIMUM SUCTION PRESSURE	
				SPEED	REV. 1/min	P1 MAX W	In A	CAPACITOR		t°	90 °
B 80/250.40 M	250	1x230 V ~	DN 40	3	2683	256	1,12	7	400	m.c.w.	2,5
				2	2374	260	1,17				
				1	1688	218	1,00				

MODEL	L	L1	L2	B	B1	B2	D	D1	D2	D3	D4	H	H1	H2	F	PACKING DIMENSIONS			VOLUME m³	WEIGHT kg
																L	B	H		
B 80/250.40 M	250	125	125	204	65	139	150	110	100	80	40	167	75	92	DN40/PN10	302	202	283	0,017	9,3

B 80/250.40 T - WET ROTOR CIRCULATORS

Pumped liquid temperature range: from -10 °C to +110 °C - Maximum operating pressure: 10 bar (1000 kPa)

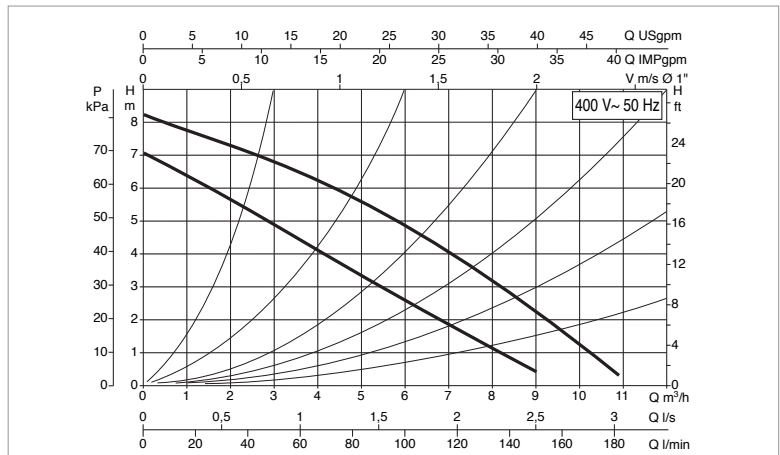
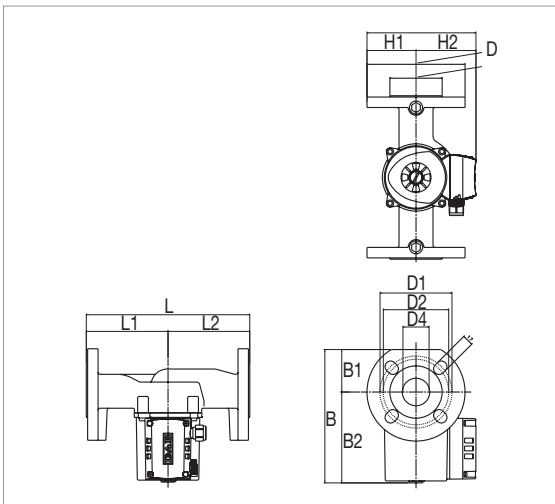

The performance curves are based on kinematic viscosity values = 1 mm²/s and density equal to 1000 kg/m³. Curve tolerance according to ISO 9906.

MODEL	CENTRE DISTANCE mm	POWER INPUT 50 Hz	COUNTERFLANGES ON REQUEST	ELECTRICAL DATA						MINIMUM SUCTION PRESSURE	
				SPEED	REV. 1/min	P1 MAX W	In A	CAPACITOR		t°	90 °
B 80/250.40 T	250	3x400 V ~	DN 40	2	2724	271	0,57	-	-	m.c.w.	2,5
				1	2226	187	0,31				

MODEL	L	L1	L2	B	B1	B2	D	D1	D2	D3	D4	H	H1	H2	F	PACKING DIMENSIONS			VOLUME m³	WEIGHT kg
																L	B	H		
B 80/250.40 T	250	125	125	204	65	139	150	110	100	80	40	167	75	92	DN40/PN10	302	202	283	0,017	9,3

B 110/250.40 M - WET ROTOR CIRCULATORS

Pumped liquid temperature range: from -10 °C to +110 °C - Maximum operating pressure: 10 bar (1000 kPa)

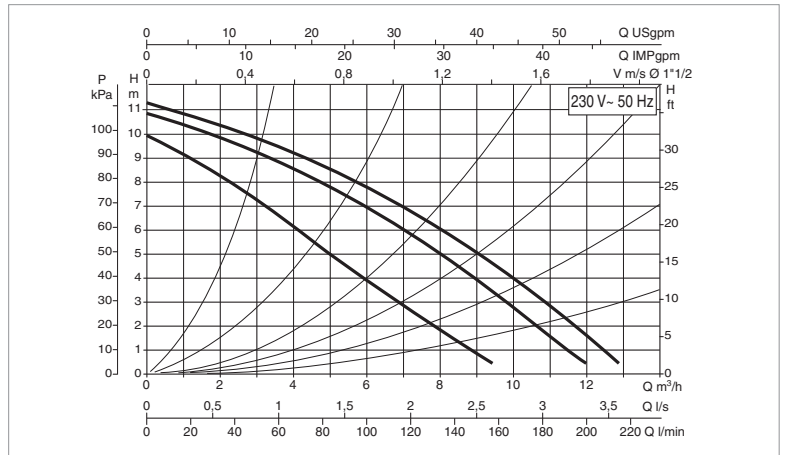
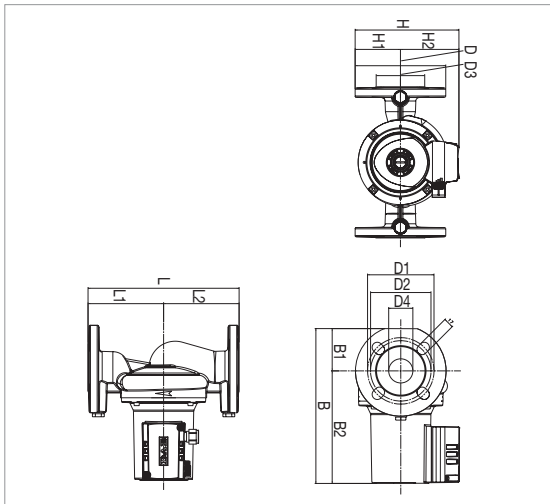

The performance curves are based on kinematic viscosity values = 1 mm²/s and density equal to 1000 kg/m³. Curve tolerance according to ISO 9906.

MODEL	CENTRE DISTANCE mm	POWER INPUT 50 Hz	COUNTERFLANGES ON REQUEST	ELECTRICAL DATA						MINIMUM SUCTION PRESSURE	
				SPEED	REV. 1/min	P1 MAX W	In A	CAPACITOR		t°	90 °
								µF	Vc		
B 110/250.40 M	250	1x230 V ~	DN 40	3 2 1	2746 2552 2052	410 393 361	1,77 1,78 1,64	12 450	m.c.w.	2,5	

MODEL	L	L1	L2	B	B1	B2	D	D1	D2	D3	D4	H	H1	H2	F	PACKING DIMENSIONS			VOLUME m ³	WEIGHT kg
																L	B	H		
B 110/250.40 M	250	125	125	256	70	186	150	110	100	80	40	172	75	97	DN40/PN10	302	202	283	0,017	9,2

B 110/250.40 T - WET ROTOR CIRCULATORS

Pumped liquid temperature range: from -10 °C to +110 °C - Maximum operating pressure: 10 bar (1000 kPa)

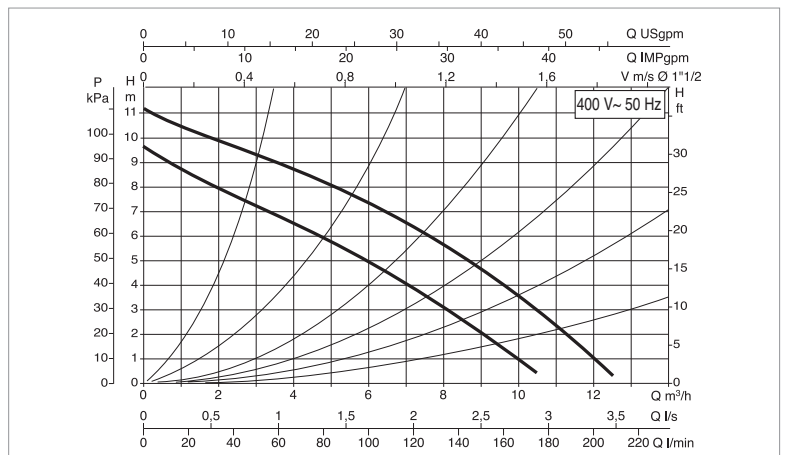
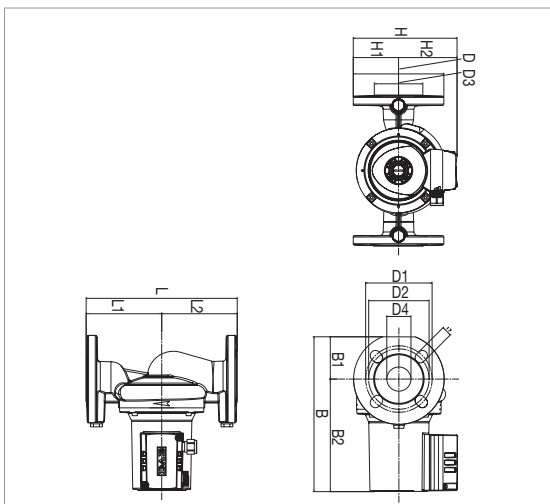

The performance curves are based on kinematic viscosity values = 1 mm²/s and density equal to 1000 kg/m³. Curve tolerance according to ISO 9906.

MODEL	CENTRE DISTANCE mm	POWER INPUT 50 Hz	COUNTERFLANGES ON REQUEST	ELECTRICAL DATA						MINIMUM SUCTION PRESSURE	
				SPEED	REV. 1/min	P1 MAX W	In A	CAPACITOR		t°	90 °
								µF	Vc		
B 110/250.40 T	250	3x400 V ~	DN 40	2 1	2759 2341	403 289	0,90 0,48	- -	m.c.w.	2,5	

MODEL	L	L1	L2	B	B1	B2	D	D1	D2	D3	D4	H	H1	H2	F	PACKING DIMENSIONS			VOLUME m ³	WEIGHT kg
																L	B	H		
B 110/250.40 T	250	125	125	256	70	186	150	110	100	80	40	168	75	93	DN40/PN10	302	202	283	0,017	9,3

D 50/250.40 M - WET ROTOR CIRCULATORS

Pumped liquid temperature range: from -10 °C to +110 °C - Maximum operating pressure: 10 bar (1000 kPa)

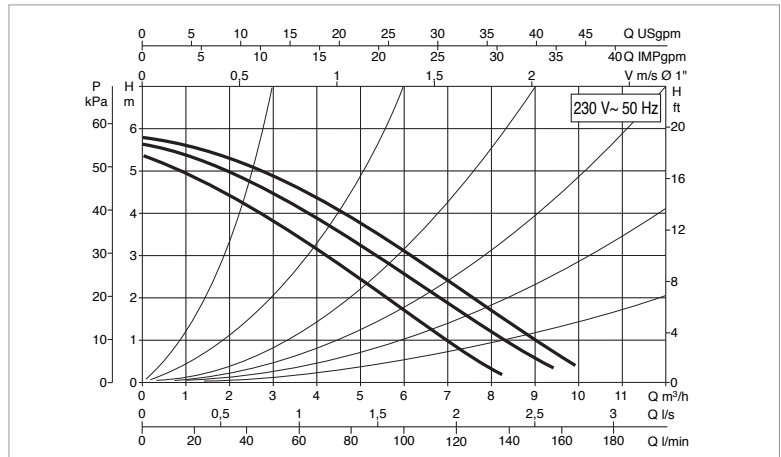
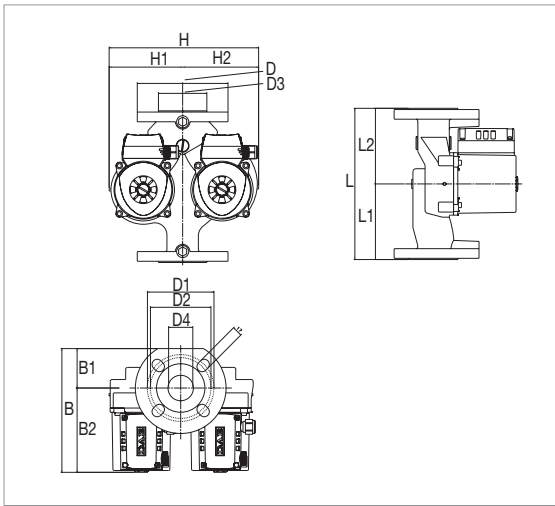

The performance curves are based on kinematic viscosity values = 1 mm²/s and density equal to 1000 kg/m³. Curve tolerance according to ISO 9906.

MODEL	CENTRE DISTANCE mm	POWER INPUT 50 Hz	COUNTERFLANGES ON REQUEST	ELECTRICAL DATA						MINIMUM SUCTION PRESSURE	
				SPEED	REV. 1/min	P1 MAX W	In A	CAPACITOR		t°	90 °
D 50/250.40 M	250	1x230 V ~	DN 40 - PN 10	3	2766	195	0,95	4	400	m.c.w.	1,5
				2	2616	194	0,95				
				1	2215	180	0,85				

MODEL	L	L1	L2	B	B1	B2	D	D1	D2	D3	D4	H	H1	H2	F	PACKING DIMENSIONS			VOLUME m ³	WEIGHT kg
																L	B	H		
D 50/250.40 M	250	125	125	204	65	139	150	110	100	80	40	247	122	126	DN40/PN10	335	298	283	0,03	15,3

D 50/250.40 T - WET ROTOR CIRCULATORS

Pumped liquid temperature range: from -10 °C to +110 °C - Maximum operating pressure: 10 bar (1000 kPa)

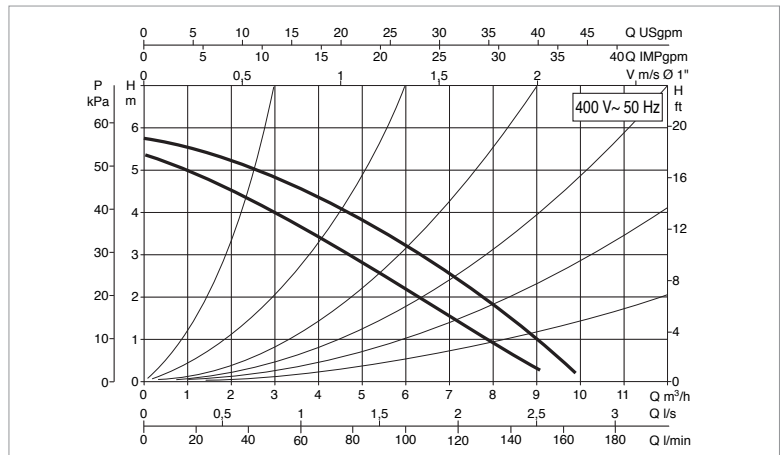
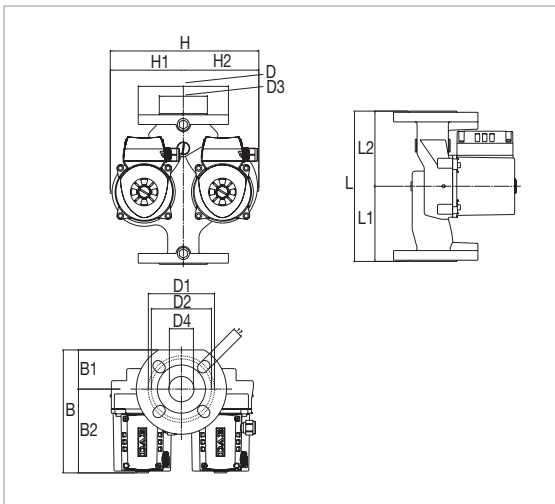

The performance curves are based on kinematic viscosity values = 1 mm²/s and density equal to 1000 kg/m³. Curve tolerance according to ISO 9906.

MODEL	CENTRE DISTANCE mm	POWER INPUT 50 Hz	UNIONS ON REQUEST	ELECTRICAL DATA						MINIMUM SUCTION PRESSURE	
				SPEED	REV. 1/min	P1 MAX W	In A	CAPACITOR		t°	90 °
D 50/250.40 T	250	3x400 V ~	DN 40 - PN 10	2	2838	201	0,50	-	-	m.c.w.	1,5
				1	2520	129	0,23				

MODEL	L	L1	L2	B	B1	B2	D	D1	D2	D3	D4	H	H1	H2	F	PACKING DIMENSIONS			VOLUME m ³	WEIGHT kg
																L	B	H		
D 50/250.40 T	250	125	125	204	65	139	150	110	100	80	40	247	122	126	DN40/PN10	335	298	283	0,03	15,8

D 56/250.40 M - WET ROTOR CIRCULATORS

Pumped liquid temperature range: from -10 °C to +110 °C - Maximum operating pressure: 10 bar (1000 kPa)

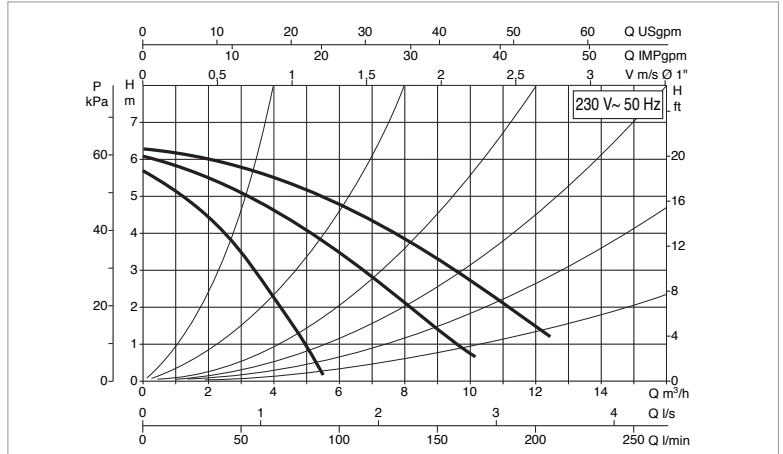
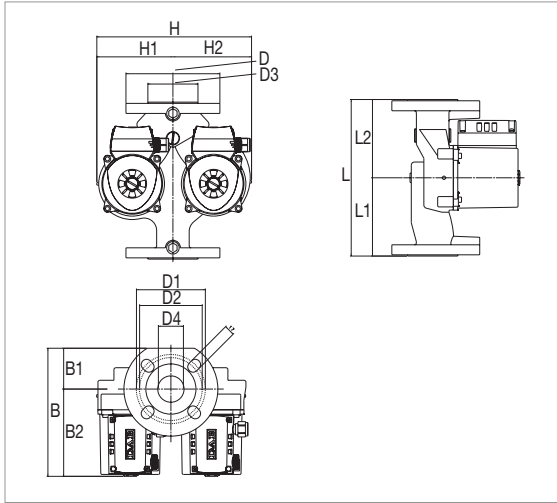

The performance curves are based on kinematic viscosity values = 1 mm²/s and density equal to 1000 kg/m³. Curve tolerance according to ISO 9906.

MODEL	CENTRE DISTANCE mm	POWER INPUT 50 Hz	COUNTERFLANGES ON REQUEST	ELECTRICAL DATA						MINIMUM SUCTION PRESSURE	
				SPEED	REV. 1/min	P1 MAX W	In A	CAPACITOR		t°	90°
D 56/250.40 M	250	1x230 V ~	DN 40 - PN 10	3	2658	271	1,18	7	400	m.c.w.	1,5
				2	2117	294	1,32				
				1	1394	224	1,00				

MODEL	L	L1	L2	B	B1	B2	D	D1	D2	D3	D4	H	H1	H2	F	PACKING DIMENSIONS			VOLUME m³	WEIGHT kg
																L	B	H		
D 56/250.40 M	250	125	125	204	65	139	150	110	100	80	40	247	122	126	DN40/PN10	355	298	283	0,03	15,8

D 56/250.40 T - WET ROTOR CIRCULATORS

Pumped liquid temperature range: from -10 °C to +110 °C - Maximum operating pressure: 10 bar (1000 kPa)

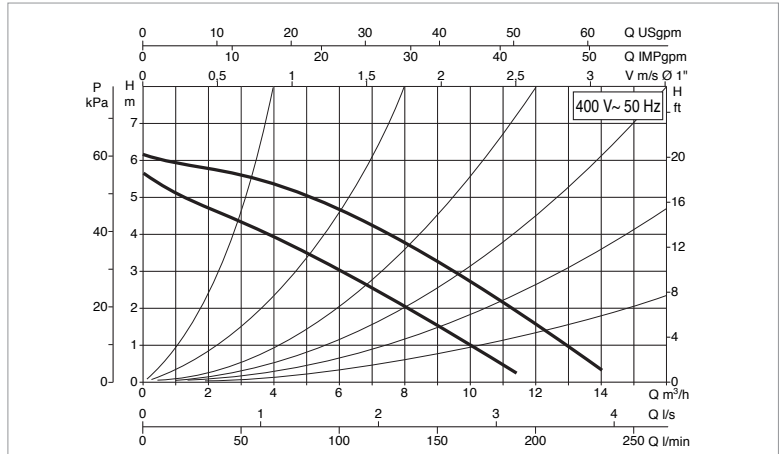
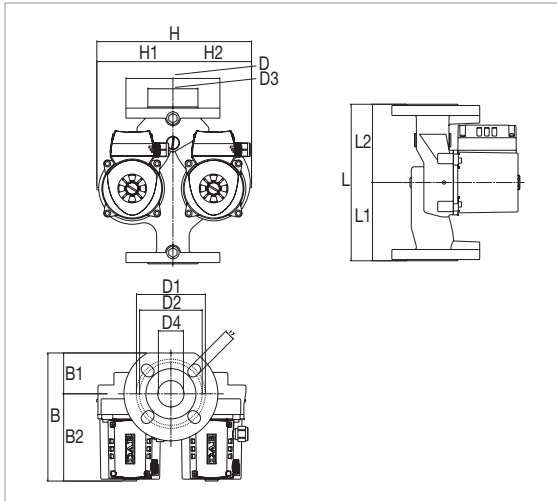

The performance curves are based on kinematic viscosity values = 1 mm²/s and density equal to 1000 kg/m³. Curve tolerance according to ISO 9906.

MODEL	CENTRE DISTANCE mm	POWER INPUT 50 Hz	UNIONS ON REQUEST	ELECTRICAL DATA						MINIMUM SUCTION PRESSURE	
				SPEED	REV. 1/min	P1 MAX W	In A	CAPACITOR		t°	90°
D 56/250.40 T	250	3x400 V ~	DN 40 - PN 10	2	2708	291	0,60	-	-	m.c.w.	1,5
				1	2178	200	0,33				

MODEL	L	L1	L2	B	B1	B2	D	D1	D2	D3	D4	H	H1	H2	F	PACKING DIMENSIONS			VOLUME m³	WEIGHT kg
																L	B	H		
D 56/250.40 T	250	125	125	204	65	139	150	110	100	80	40	247	122	126	DN40/PN10	335	298	283	0,03	15,4

D 80/250.40 M - WET ROTOR CIRCULATORS

Pumped liquid temperature range: from -10 °C to +110 °C - Maximum operating pressure: 10 bar (1000 kPa)

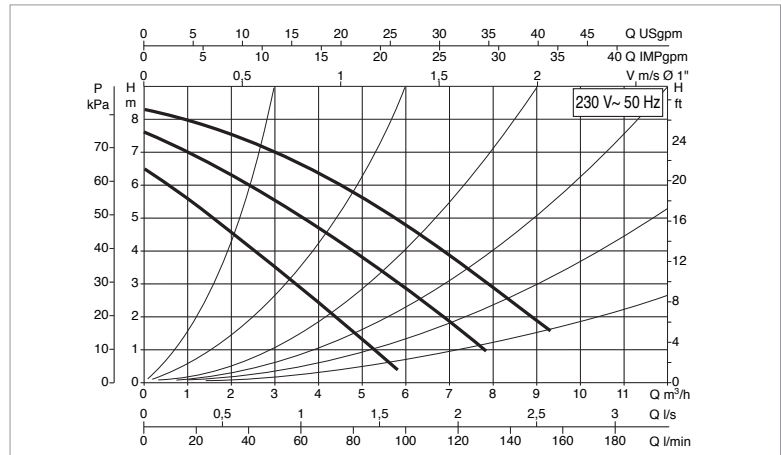
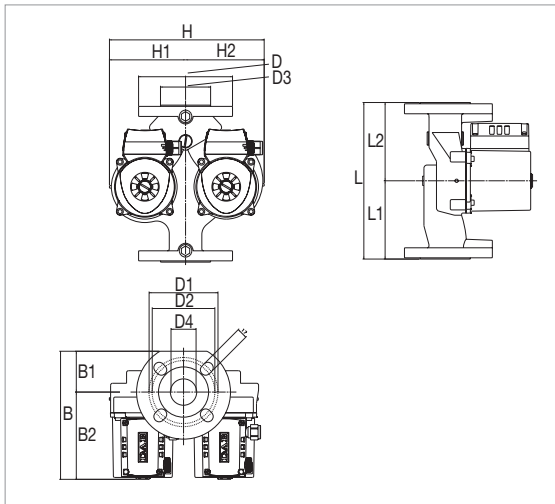

The performance curves are based on kinematic viscosity values = 1 mm²/s and density equal to 1000 kg/m³. Curve tolerance according to ISO 9906.

MODEL	CENTRE DISTANCE mm	POWER INPUT 50 Hz	COUNTERFLANGES ON REQUEST	ELECTRICAL DATA						MINIMUM SUCTION PRESSURE	
				SPEED	REV. 1/min	P1 MAX W	In A	CAPACITOR		t°	90 °
D 80/250.40 M	250	1x230 V ~	DN 40 - PN 10	3	2683	256	1,12	7	400	m.c.w.	2,5
				2	2374	260	1,17				
				1	1688	218	1,00				

MODEL	L	L1	L2	B	B1	B2	D	D1	D2	D3	D4	H	H1	H2	F	PACKING DIMENSIONS			VOLUME m ³	WEIGHT kg
																L	B	H		
D 80/250.40 M	250	125	125	204	65	139	150	110	100	80	40	247	122	126	DN40/PN10	355	298	283	0,03	15,8

D 80/250.40 T - WET ROTOR CIRCULATORS

Pumped liquid temperature range: from -10 °C to +110 °C - Maximum operating pressure: 10 bar (1000 kPa)

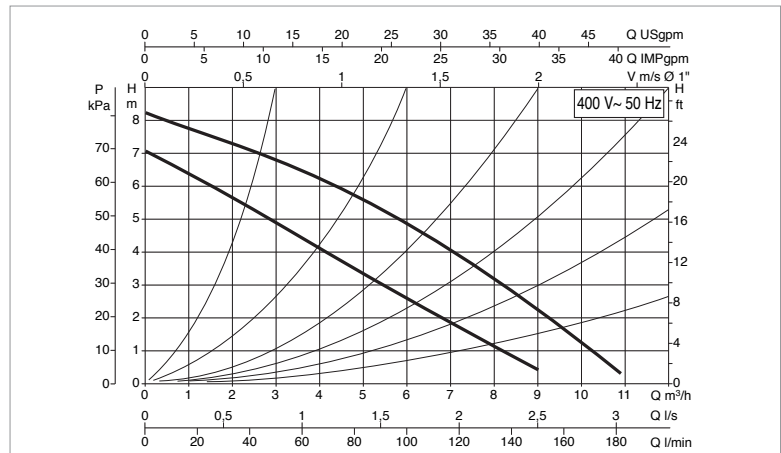
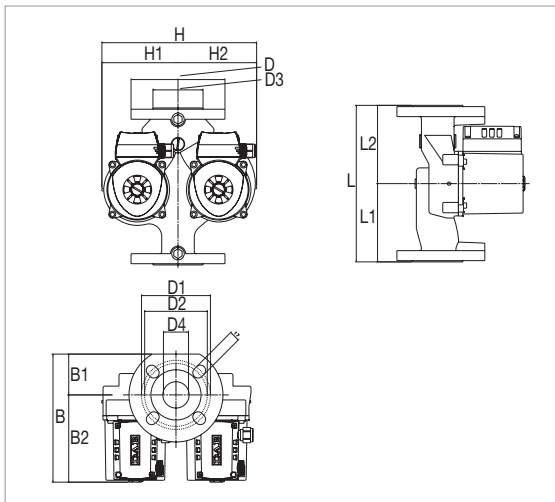

The performance curves are based on kinematic viscosity values = 1 mm²/s and density equal to 1000 kg/m³. Curve tolerance according to ISO 9906.

MODEL	CENTRE DISTANCE mm	POWER INPUT 50 Hz	COUNTERFLANGES ON REQUEST	ELECTRICAL DATA						MINIMUM SUCTION PRESSURE	
				SPEED	REV. 1/min	P1 MAX W	In A	CAPACITOR		t°	90 °
D 80/250.40 T	250	3x400 V ~	DN 40 - PN 10	2	2724	271	0,57	-	-	m.c.w.	2,5
				1	2226	187	0,31				

MODEL	L	L1	L2	B	B1	B2	D	D1	D2	D3	D4	H	H1	H2	F	PACKING DIMENSIONS			VOLUME m ³	WEIGHT kg
																L	B	H		
D 80/250.40 T	250	125	125	204	65	139	150	110	100	80	40	247	122	126	DN40/PN10	335	298	283	0,03	15,8

D 110/250.40 M - WET ROTOR CIRCULATORS

Pumped liquid temperature range: from -10 °C to +110 °C - Maximum operating pressure: 10 bar (1000 kPa)

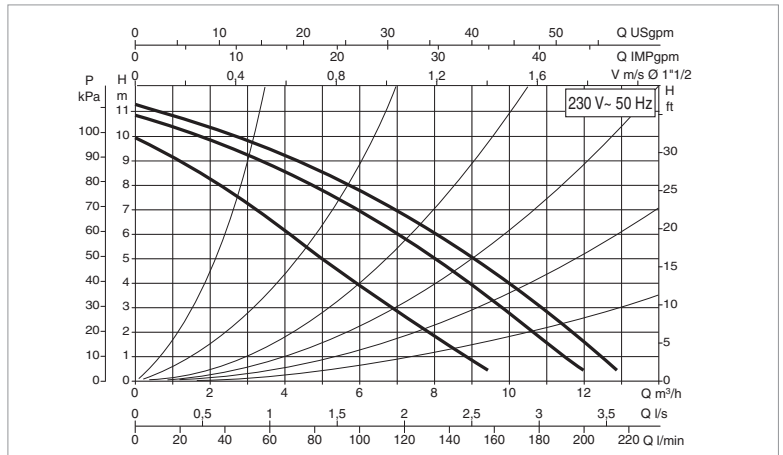
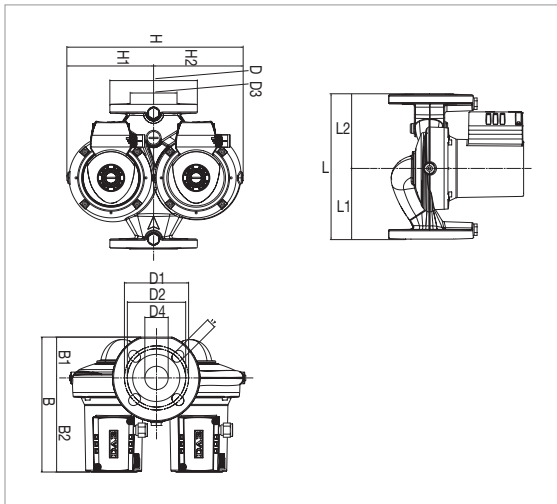

The performance curves are based on kinematic viscosity values = 1 mm²/s and density equal to 1000 kg/m³. Curve tolerance according to ISO 9906.

MODEL	CENTRE DISTANCE mm	POWER INPUT 50 Hz	COUNTERFLANGES ON REQUEST	ELECTRICAL DATA						MINIMUM SUCTION PRESSURE	
				SPEED	REV. 1/min	P1 MAX W	In A	CAPACITOR		t°	90 °
D 110/250.40 M	250	1x230 V ~	DN 40 - PN 10	3	2746	410	1,77	12	450	m.c.w.	2,5
				2	2552	393	1,78				
				1	2052	361	1,64				

MODEL	L	L1	L2	B	B1	B2	D	D1	D2	D3	D4	H	H1	H2	F	PACKING DIMENSIONS			VOLUME m ³	WEIGHT kg
																L	B	H		
D 110/250.40 M	250	122	128	231	70	161	150	110	100	80	40	302	149	154	DN40/PN10	355	298	283	0,03	16

D 110/250.40 T - WET ROTOR CIRCULATORS

Pumped liquid temperature range: from -10 °C to +110 °C - Maximum operating pressure: 10 bar (1000 kPa)

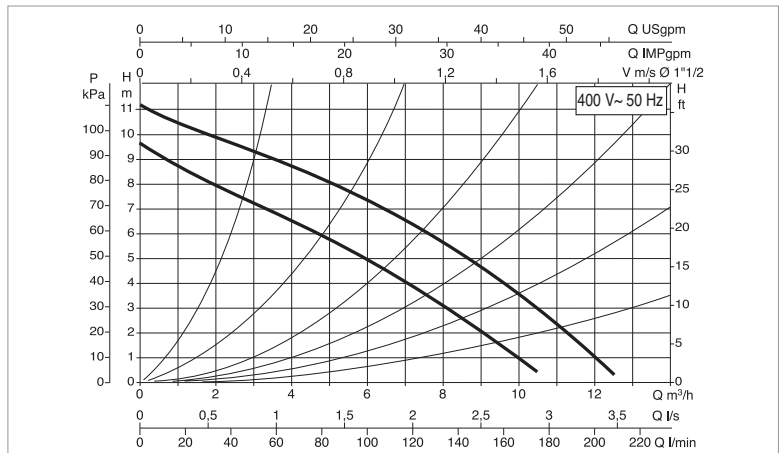
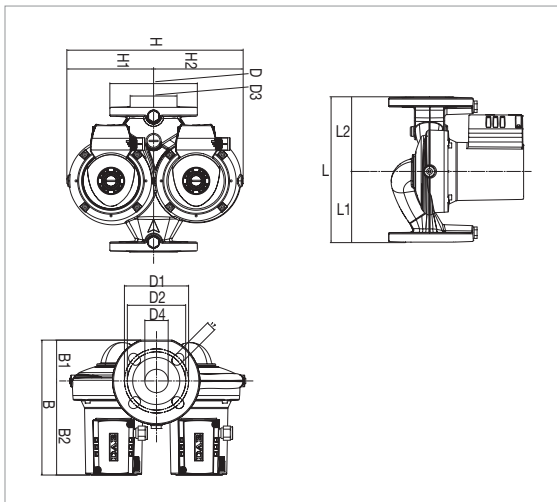

The performance curves are based on kinematic viscosity values = 1 mm²/s and density equal to 1000 kg/m³. Curve tolerance according to ISO 9906.

MODEL	CENTRE DISTANCE mm	POWER INPUT 50 Hz	UNIONS ON REQUEST	ELECTRICAL DATA						MINIMUM SUCTION PRESSURE	
				SPEED	REV. 1/min	P1 MAX W	In A	CAPACITOR		t°	90 °
D 110/250.40 T	250	3x400 V ~	DN 40 - PN 10	2	2759	403	0,90	-	-	m.c.w.	2,5
				1	2341	289	0,48				

MODEL	L	L1	L2	B	B1	B2	D	D1	D2	D3	D4	H	H1	H2	F	PACKING DIMENSIONS			VOLUME m ³	WEIGHT kg
																L	B	H		
D 110/250.40 T	250	122	128	231	70	161	150	110	100	80	40	302	149	154	DN40/PN10	355	298	283	0,03	15,8

BPH / BMH / DPH / DMH

WET ROTOR CIRCULATORS



TECHNICAL DATA

Operating range: from 1,5 a 78 m³/h with head of up to 18 metres

Liquid temperature range: for three-phase version: from -10°C to +120°C (for the models BPH-DPH 150/340.65 T and BPH-DPH 150/360.80 T; BPH-DPH 150-180/280.50 T; BPH-DPH 180/340.65 T; BPH-DPH 180/360.80 T: from -10°C to +110°C)

Pumped liquid: clean, free of solids and mineral oils, non-viscous, chemically neutral, with properties similar to water. (glycol max 30%)

Maximum operating pressure: 10 bar (1000 kPa)

Standard flanges: DN 80 in PN 6 / PN 10 (4 holes)

Minimum suction pressure: the values are shown in the corresponding tables

Installation: with HORIZONTAL MOTOR AXIS, on the delivery or return piping, with the suction port as close as possible to the expansion vessel, above the level of the boiler and as far as possible from bends, elbows, branches, to avoid water turbulence, and the consequent noise

Special executions on requests: alternative voltages and frequencies
DN 80 in PN 10 / PN 16 (8 holes) flange

Accessories: DN 40, DN 50, DN 65, DN 80 in PN 6 / PN 10 (4 slots)

APPLICATIONS

Pump for the circulation of water in residential and industrial collective heating and air conditioning systems. All the models are available both in the single and twin version.

CONSTRUCTION FEATURES

Single body consisting of the cast iron hydraulic section, and the wet rotor motor.

Aluminium motor casing. Flanged suction and delivery ports with threaded connectors for control manometers. Technopolymer impeller, tempered stainless steel motor shaft on graphite bushings lubricated by the pumped liquid. Stainless steel rotor protection liner and stator liner. Ceramic thrust ring, ethylene-propylene seal rings, and brass air breather plug. Asynchronous four-pole motor for the BMH and DMH versions, two poles for the BPH and DPH versions. The single-phase circulator has been designed for three-speed operation at 230 V, while the three-phase circulator has been designed for two-speed operation at 230 V, and 3-speed operation at 400 V. In both cases, the speed is adjusted through a special selector in the terminal box, in order to adapt the operation of the circulator to the characteristics of the system.

Built-in thermal protection in the single-phase version. For the three-phase version, the motor must be connected to the power input using an external contactor. The contactor must be connected to the thermal protection built in the motor, in order to protect it from overload at all speeds.

The twin version features an automatic swing check valve incorporated in the delivery port, to avoid water recirculating through the unit when this is not running; in addition, a blank flange is also supplied as standard, to allow either of the two motors to be removed for servicing. The standard execution of the pump body is in PN 10, compatible with PN 6 pumps to ensure interchangeability of the pumps in existing systems.

Circulator protection class: IP 44 for both the single-phase and the three-phase version

Insulation class: H - Cable gland: PG 11

Standard voltage: three-phase 230/400 V, 50 Hz

Product compliant with European Standards EN 60335-2-51

MATERIALS

N.	PARTS	MATERIALS
1	PUMP BODY	CAST IRON 200 UNI ISO 185
4	IMPELLER	TECHNOPOLYMER B
7A	MOTOR SHAFT	AISI 420 C QUENCHED AND TEMPERED STAINLESS STEEL
7B	ROTOR	-
8	STATOR	-
10	MOTOR CASING	DIE-CAST ALUMINIUM
11	BREATHER PLUG	BRASS P Cu Zn 40 Pb2 UNI 5705
100	TERMINAL BOX	-
127	SEAL RING	ETHYLENE PROPYLENE (EPDM)
128	STATOR LINER	AISI 321 STAINLESS STEEL AISI 304 QUENCHED AND TEMPERED
129	ROTOR LINER	AISI 321 STAINLESS STEEL AISI 304 QUENCHED AND TEMPERED
130	CLOSING FLANGE	CAST IRON 200 UNI ISO 185
131	THRUST RING SUPPORT	AISI 304 L STAINLESS STEEL
132	BUSHINGS	EC 941 CARBON

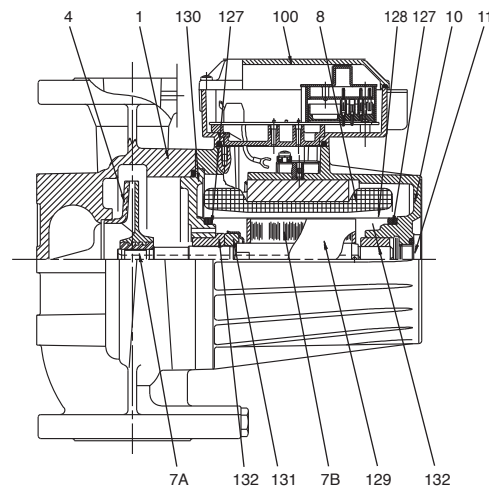

BPH / BMH / DPH / DMH

WET ROTOR CIRCULATORS

- Legend:
(example)

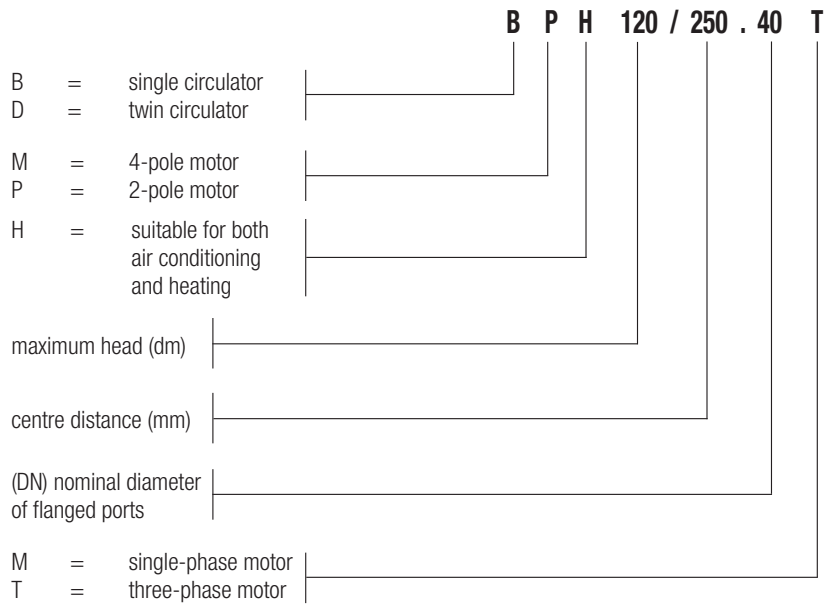

TERMINAL BOX POSITION

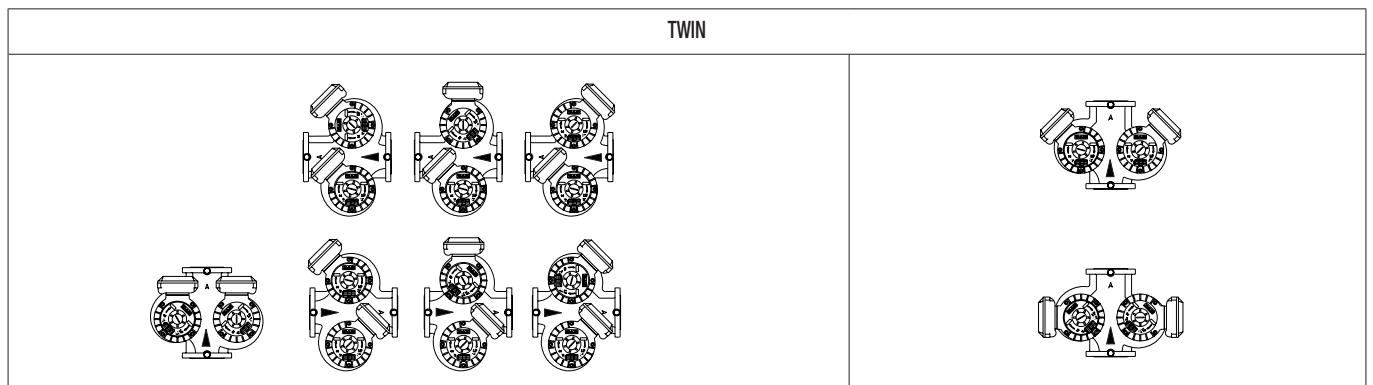
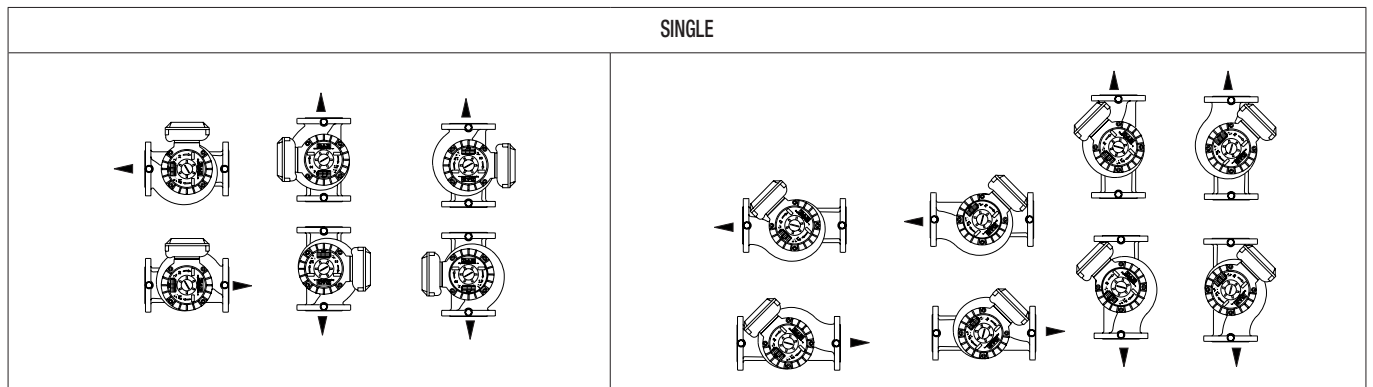

BPH / BMH / DPH / DMH

WET ROTOR CIRCULATORS

PERFORMANCE RANGE

The performance curves are based on kinematic viscosity values = 1 mm²/s and density equal to 1000 kg/m³. Curve tolerance according to ISO 9906.

GRAPHIC SELECTION TABLE

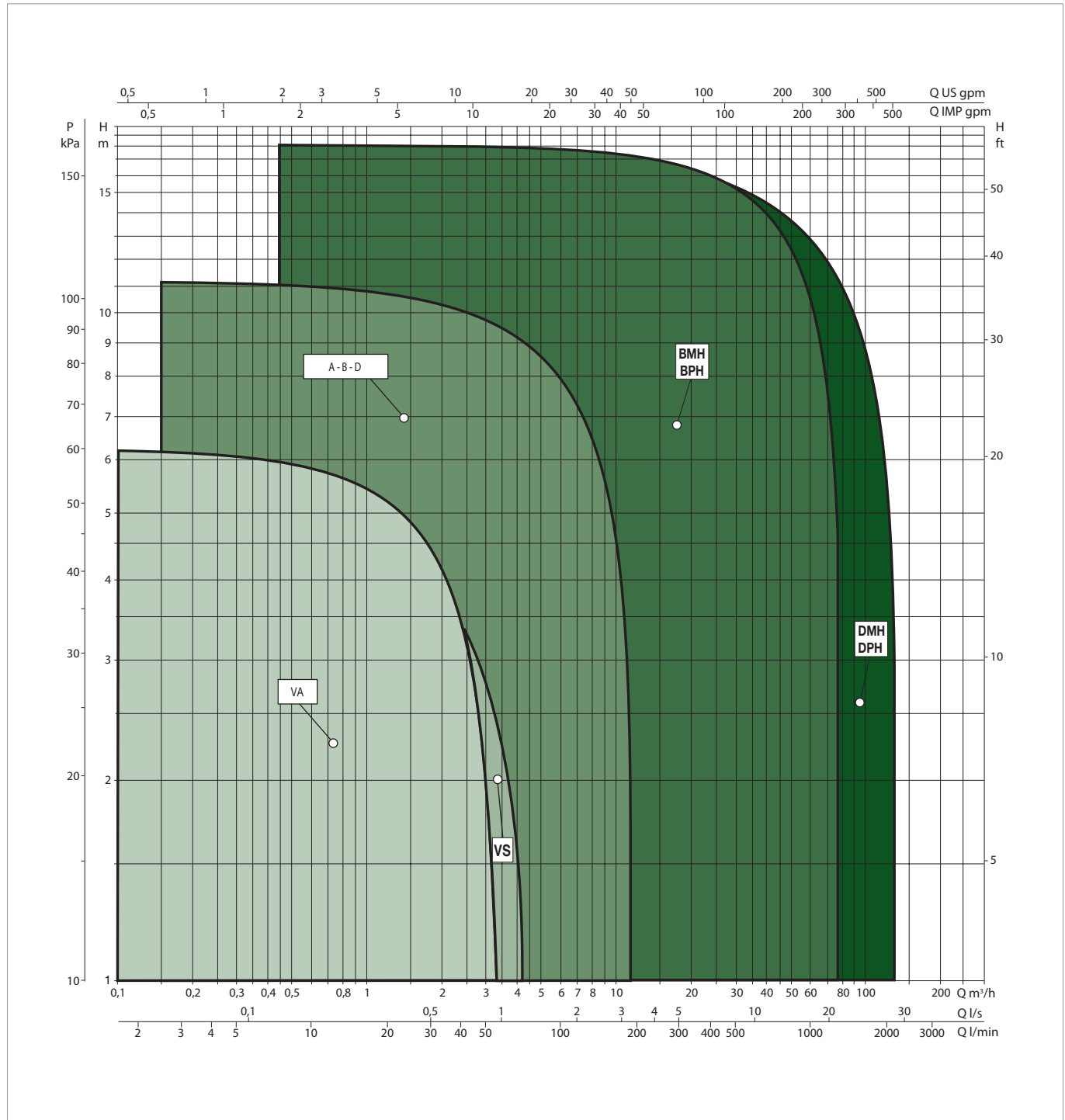

WET ROTOR CIRCULATORS

BPH / BMH / DPH / DMH

WET ROTOR CIRCULATORS

SELECTION TABLE - BPH / BMH

MODEL	Q=m³/h	0	1,8	2,4	3	4,2	5,4	7,2	9,6	12	14,4	18	24	30	36	42	54	72
	Q=l/min	0	30	40	50	70	90	120	160	200	240	300	400	500	600	700	900	1200
BMH 30/250.40 T		3,3	3,1	2,95	2,85	2,5	2,1	1,15										
BPH 60/250.40 M		7,2	6,8	6,7	6,5	6,2	5,8	5	3,7	2								
BPH 60/250.40 T		7,65	7,4	7,3	7,2	6,8	6,4	5,45	3,9	2,25								
BPH 120/250.40 M		11	10,3	10,1	9,8	9,2	8,6	7,65	6,2	4,35	2,4							
BPH 120/250.40 T		12		11	10,7	10,1	9,5	8,4	6,8	4,7	2,2							
BMH 30/280.50 T		3,15		3,02	3	2,93	2,85	2,65	2,3	1,75	1,2							
BMH 60/280.50 T		5,83		5,65	5,6	5,49	5,35	5,1	4,75	4,2	3,65	2,62						
BPH 60/280.50 M		7,65	7,5	7,45	7,4	7,3	7,2	6,98	6,7	6,2	5,75	4,6	2,3					
BPH 60/280.50 T		7,95		7,75	7,7	7,6	7,5	7,35	6,92	6,45	5,85	4,65	2,4					
BPH 120/280.50 M		11,3				10,8	10,5	10,3	9,9	9,4	8,5	7,2	4,8	2,1				
BPH 120/280.50 T		11,7				11,3	11	10,75	10,25	9,6	8,9	7,75	5,4	2,6				
BPH 150/280.50 T		15				14,6	14,4	14	13,6	12,7	11,8	10,5	7,5					
BPH 180/280.50 T		18,4						17,4	17	16,4	15,6	14,4	12	8,8	5,2			
BMH 30/340.65 T	H (m)	3,15				3,09	3,02	2,98	2,85	2,55	2,25	1,65						
BMH 60/340.65 T		5,4				5,15	5,05	4,9	4,7	4,45	4,1	3,45	2,25					
BPH 60/340.65 M		6,8	6,79	6,75	6,7	6,6	6,57	6,5	6,35	6,2	5,95	5,5	4,35	2,85	1,2			
BPH 60/340.65 T		7,4				7,35	7,3	7,24	7,1	6,9	6,65	6,15	4,9	3,3	1,4			
BPH 120/340.65 T		10,9				10,75	10,68	10,6	10,5	10,38	10,2	9,8	8,7	7,15	5,2	3		
BPH 150/340.65 T		14,9				14,88	14,83	14,75	14,65	14,55	14,3	13,88	12,65	11	9,35	7,15		
BPH 180/340.65 T		17,9						17,8	17,7	17,5	17,3	16,8	15,7	14,1	12,1	10		
BMH 30/360.80 T		3,9						3,85	3,8	3,75	3,65	3,48	3,1	2,45	1,75			
BMH 60/360.80 T		5,7						5,66	5,61	5,59	5,5	5,4	5	4,55	3,9	3,1		
BPH 120/360.80 T		11,8						11,65	11,58	11,5	11,4	11,25	10,75	10,2	9,39	8,37	5,65	
BPH 150/360.80 T		15,3						15,1	15,06	14,99	14,92	14,75	14,5	14	13,4	12,4	10,3	6
BPH 180/360.80 T		17,5						17,4	17,25	17,1	16,8	16,25	15	13,7	12	10,1	5,5	

SELECTION TABLE - DPH / DMH

MODEL	Q=m³/h	0	1,8	2,4	3	4,2	5,4	7,2	9,6	12	14,4	18	24	30	36	42	54	72
	Q=l/min	0	30	40	50	70	90	120	160	200	240	300	400	500	600	700	900	1200
DMH 30/250.40 T		3,3	3,1	2,95	2,85	2,5	2,1	1,15										
DPH 60/250.40 M		7,2	6,8	6,7	6,5	6,2	5,8	5	3,7	2								
DPH 60/250.40 T		7,65	7,4	7,3	7,2	6,8	6,4	5,45	3,9	2,25								
DPH 120/250.40 M		11	10,3	10,1	9,8	9,2	8,6	7,65	6,2	4,35	2,4							
DPH 120/250.40 T		12		11	10,7	10,1	9,5	8,4	6,8	4,7	2,2							
DMH 30/280.50 T		3,15		3,02	3	2,93	2,85	2,65	2,3	1,75	1,2							
DMH 60/280.50 T		5,83		5,65	5,6	5,49	5,35	5,1	4,75	4,2	3,65	2,62						
DPH 60/280.50 M		7,65	7,5	7,45	7,4	7,3	7,2	6,98	6,7	6,2	5,75	4,6	2,3					
DPH 60/280.50 T		7,95		7,75	7,7	7,6	7,5	7,35	6,92	6,45	5,85	4,65	2,4					
DPH 120/280.50 M		11,3				10,8	10,5	10,3	9,9	9,4	8,5	7,2	4,8	2,1				
DPH 120/280.50 T		11,7				11,3	11	10,75	10,25	9,6	8,9	7,75	5,4	2,6				
DPH 150/280.50 T		15				14,6	14,4	14	13,6	12,7	11,8	10,5	7,5					
DPH 180/280.50 T		18,4						17,4	17	16,4	15,6	14,4	12	8,8	5,2			
DMH 30/340.65 T	H (m)	3,15				3,09	3,02	2,98	2,85	2,55	2,25	1,65						
DMH 60/340.65 T		5,4				5,15	5,05	4,9	4,7	4,45	4,1	3,45	2,25					
DPH 60/340.65 M		6,8	6,79	6,75	6,7	6,6	6,57	6,5	6,35	6,2	5,95	5,5	4,35	2,85	1,2			
DPH 60/340.65 T		7,4				7,35	7,3	7,24	7,1	6,9	6,65	6,15	4,9	3,3	1,4			
DPH 120/340.65 T		10,9				10,75	10,68	10,6	10,5	10,38	10,2	9,8	8,7	7,15	5,2	3		
DPH 150/340.65 T		14,9				14,88	14,83	14,75	14,65	14,55	14,3	13,88	12,65	11	9,35	7,15		
DPH 180/340.65 T		17,9						17,8	17,7	17,5	17,3	16,8	15,7	14,1	12,1	10		
DMH 30/360.80 T		3,9						3,85	3,8	3,75	3,65	3,48	3,1	2,45	1,75			
DMH 60/360.80 T		5,7						5,66	5,61	5,59	5,5	5,4	5	4,55	3,9	3,1		
DPH 120/360.80 T		11,8						11,65	11,58	11,5	11,4	11,25	10,75	10,2	9,39	8,37	5,65	
DPH 150/360.80 T		15,3						15,1	15,06	14,99	14,92	14,75	14,5	14	13,4	12,4	10,3	6
DPH 180/360.80 T		17,5						17,4	17,25	17,1	16,8	16,25	15	13,7	12	10,1	5,5	

WET ROTOR CIRCULATORS

BMH 30/250.40 T - WET ROTOR CIRCULATORS

Pumped liquid temperature range: from -10 °C to +120 °C - Maximum operating pressure: 10 bar (1000 kPa)

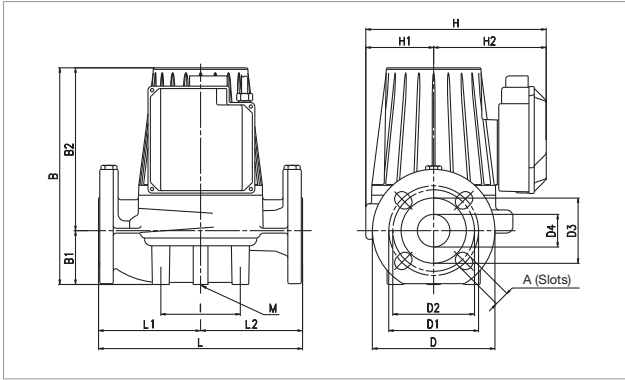

The performance curves are based on kinematic viscosity values = 1 mm²/s and density equal to 1000 kg/m³. Curve tolerance according to ISO 9906.

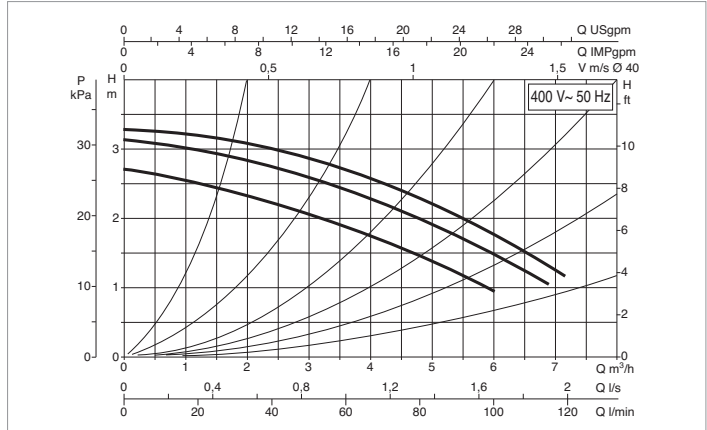

MODEL	CENTRE DISTANCE mm	COUNTERFLANGES ON REQUEST	ELECTRICAL DATA					MINIMUM SUCTION PRESSURE				
			POWER INPUT 50 Hz	SPEED	REV. 1/min	P1 MAX W	In A	t°	75°	90°	110°	120°
BMH 30/250.40 T	250	DN 40 - PN 10	3x230 V ~	2	1340	100	0.48	m.c.w.	0.9	4	-	18
			1	1260	88	0.39						
			3x400 V ~	3	1440	192	0.78					
			2	1430	155	0.58						
			1	1260	88	0.23						

MODEL	L	L1	L2	A	B	B1	B2	D	D1	D2	D3	D4	I	I1	I2	I3	M	H	H1	H2	WEIGHT kg
BMH 30/250.40 T	250	125	125	18	266	66	200	150	110	100	80	40	100	-	-	-	M10	221	83	138	17,5

BPH 60/250.40 M - WET ROTOR CIRCULATORS

Pumped liquid temperature range: from -10 °C to +110 °C - Maximum operating pressure: 10 bar (1000 kPa)

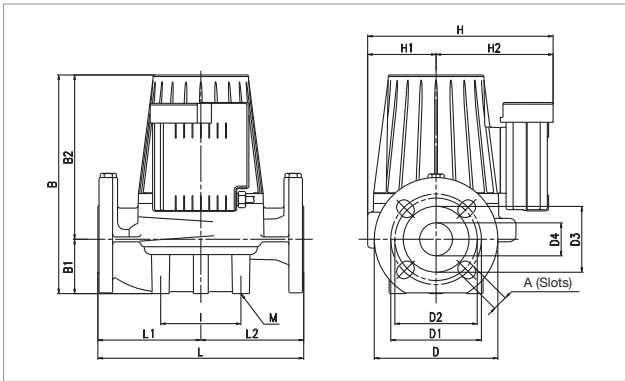

The performance curves are based on kinematic viscosity values = 1 mm²/s and density equal to 1000 kg/m³. Curve tolerance according to ISO 9906.

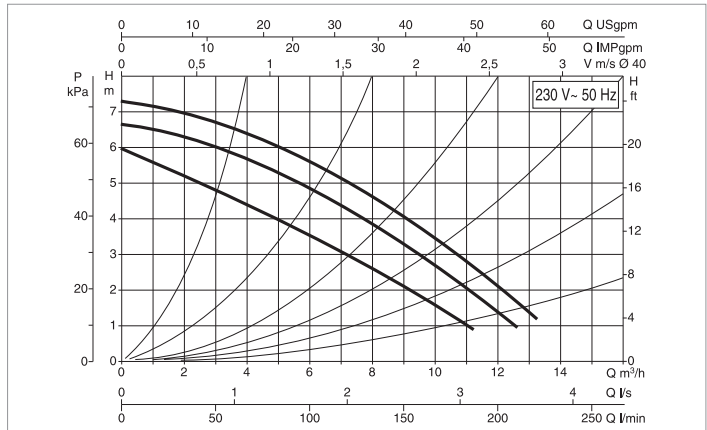

MODEL	CENTRE DISTANCE mm	FLANGES ON REQUEST	ELECTRICAL DATA					MINIMUM SUCTION PRESSURE				
			POWER INPUT 50 Hz	SPEED	REV. 1/min	P1 MAX W	In A	t°	75°	90°	110°	120°
BPH 60/250.40 M	250	DN 40 - PN 10	1x230 V ~	3	2830	316	1.43	m.c.w.	1.6	4	14	-
				2	2750	309	1.53					
				1	2410	292	1.51					

MODEL	L	L1	L2	A	B	B1	B2	D	D1	D2	D3	D4	I	I1	I2	I3	M	H	H1	H2	WEIGHT kg
BPH 60/250.40 M	250	125	125	18	266	66	200	150	110	100	80	40	100	-	-	-	M10	221	83	138	17,5

BPH 60/250.40 T - WET ROTOR CIRCULATORS

Pumped liquid temperature range: from -10 °C to +120 °C - Maximum operating pressure: 10 bar (1000 kPa)

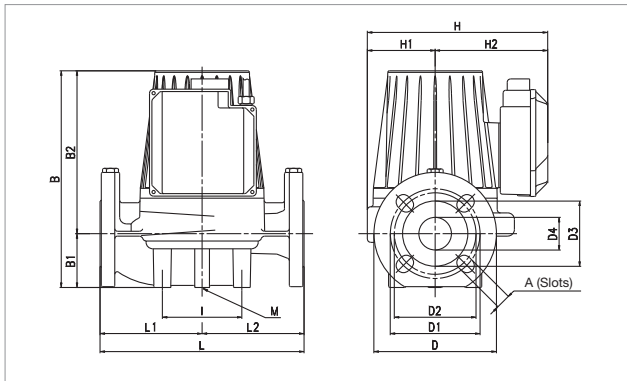

The performance curves are based on kinematic viscosity values = 1 mm²/s and density equal to 1000 kg/m³. Curve tolerance according to ISO 9906.

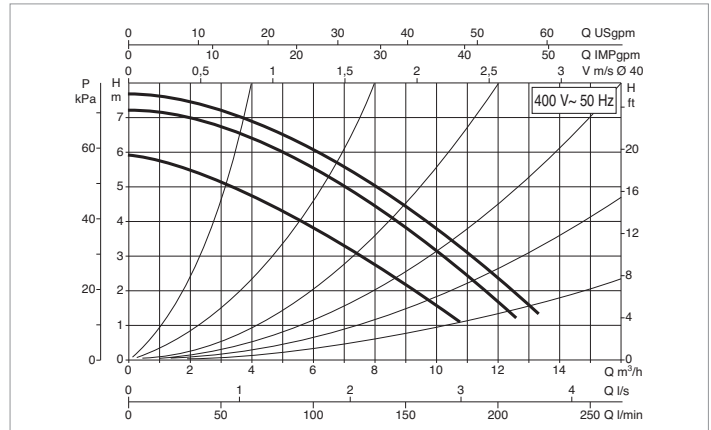

MODEL	CENTRE DISTANCE mm	COUNTERFLANGES ON REQUEST	ELECTRICAL DATA					MINIMUM SUCTION PRESSURE				
			POWER INPUT 50 Hz	SPEED	REV. 1/min	P1 MAX W	In A	t°	75°	90°	110°	120°
BPH 60/250.40 T	250	DN 40 - PN 10	3x230 V ~	2 1	2570 2420	253 229	0.81 0.72	m.c.w.	1.6	4	-	19
			3x400 V ~	3 2 1	2850 2810 2430	348 316 232	0.99 0.75 0.42					

MODEL	L	L1	L2	A	B	B1	B2	D	D1	D2	D3	D4	I	I1	I2	I3	M	H	H1	H2	WEIGHT kg
BPH 60/250.40 T	250	125	125	18	266	66	200	150	110	100	80	40	100	-	-	-	M10	221	83	138	17,5

BPH 120/250.40 M - WET ROTOR CIRCULATORS

Pumped liquid temperature range: from -10 °C to +110 °C - Maximum operating pressure: 10 bar (1000 kPa)

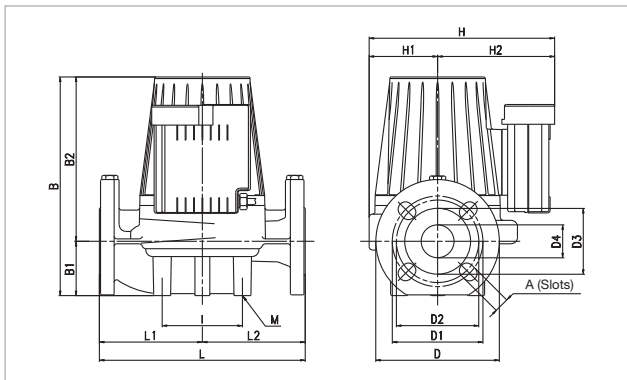

The performance curves are based on kinematic viscosity values = 1 mm²/s and density equal to 1000 kg/m³. Curve tolerance according to ISO 9906.

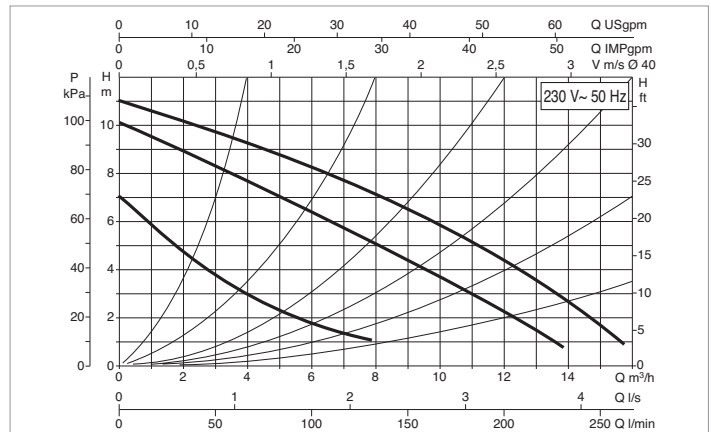

MODEL	CENTRE DISTANCE mm	COUNTERFLANGES ON REQUEST	ELECTRICAL DATA					MINIMUM SUCTION PRESSURE				
			POWER INPUT 50 Hz	SPEED	REV. 1/min	P1 MAX W	In A	t°	75°	90°	110°	120°
BPH 120/250.40 M	250	DN 40 - PN 10	1x230 V ~	3 2 1	2650 2320 1520	510 498 376	2.24 2.35 1.96	m.c.w.	6	9	18	-

MODEL	L	L1	L2	A	B	B1	B2	D	D1	D2	D3	D4	I	I1	I2	I3	M	H	H1	H2	WEIGHT kg
BPH 120/250.40 M	250	125	125	18	266	66	200	150	110	100	80	40	100	-	-	-	M10	221	83	138	17,5

BPH 120/250.40 T - WET ROTOR CIRCULATORS

Pumped liquid temperature range: from -10 °C to +120 °C - Maximum operating pressure: 10 bar (1000 kPa)

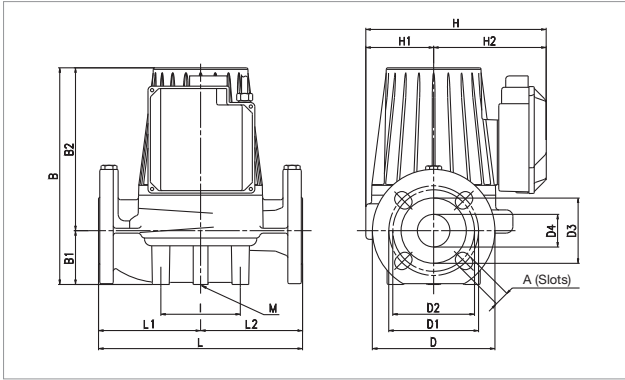

The performance curves are based on kinematic viscosity values = 1 mm²/s and density equal to 1000 kg/m³. Curve tolerance according to ISO 9906.

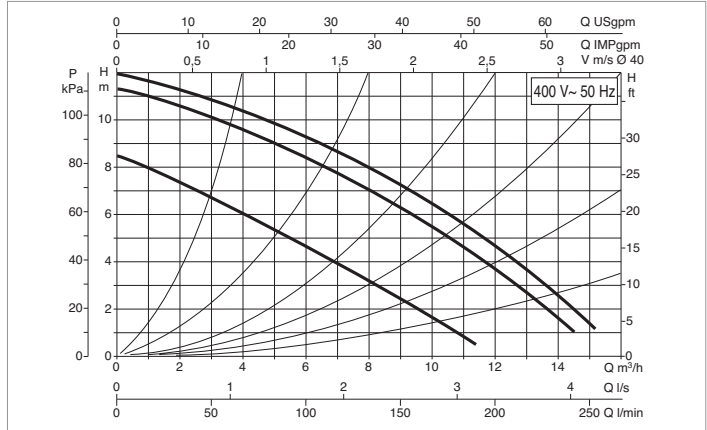

MODEL	CENTRE DISTANCE mm	COUNTERFLANGES ON REQUEST	ELECTRICAL DATA					MINIMUM SUCTION PRESSURE				
			POWER INPUT 50 Hz	SPEED	REV. 1/min	P1 MAX W	In A	t°	75°	90°	110°	120°
BPH 120/250.40 T	250	DN 40 - PN 10	3x230 V ~	2	2300	395	1.2	m.c.w.	6	9	-	23
			3x400 V ~	1	2070	340	1.07					
				3	2780	536	1.16					
				2	2710	499	0.98					
				1	2080	339	0.62					

MODEL	L	L1	L2	A	B	B1	B2	D	D1	D2	D3	D4	I	I1	I2	I3	M	H	H1	H2	WEIGHT kg
BPH 120/250.40 T	250	125	125	18	266	66	200	150	110	100	80	40	100	-	-	-	M10	221	83	138	17,5

BMH 30/280.50 T - WET ROTOR CIRCULATORS

Pumped liquid temperature range: from -10 °C to +120 °C - Maximum operating pressure: 10 bar (1000 kPa)

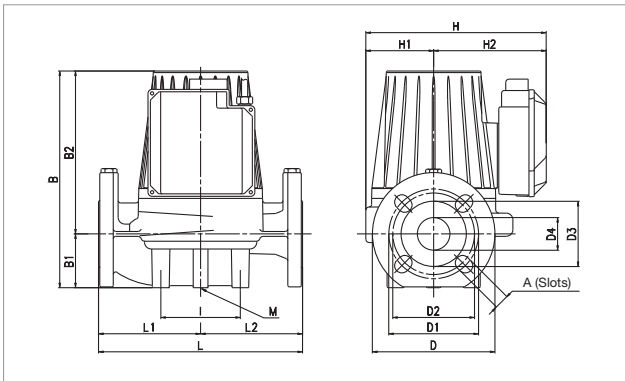

The performance curves are based on kinematic viscosity values = 1 mm²/s and density equal to 1000 kg/m³. Curve tolerance according to ISO 9906.

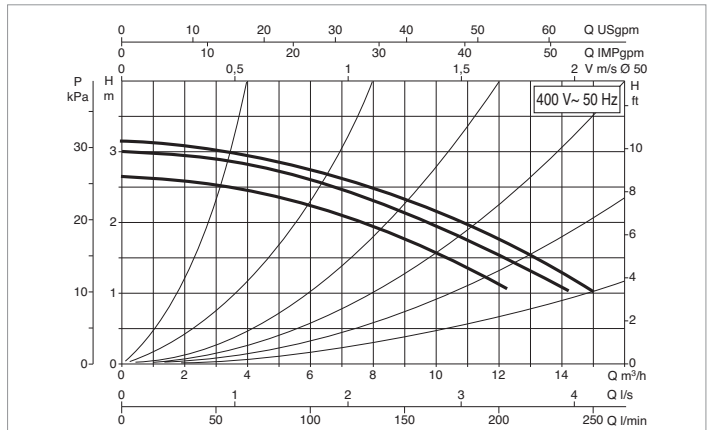

MODEL	CENTRE DISTANCE mm	COUNTERFLANGES ON REQUEST	ELECTRICAL DATA					MINIMUM SUCTION PRESSURE				
			POWER INPUT 50 Hz	SPEED	REV. 1/min	P1 MAX W	In A	t°	75°	90°	110°	120°
BMH 30/280.50 T	280	DN 50 - PN 10	3x230 V ~	2	1390	148	0.7	m.c.w.	0.9	4	-	18
			3x400 V ~	1	1340	134	0.55					
				3	1460	255	1.12					
				2	1450	216	0.83					
				1	1350	131	0.32					

MODEL	L	L1	L2	A	B	B1	B2	D	D1	D2	D3	D4	I	I1	I2	I3	M	H	H1	H2	WEIGHT kg
BMH 30/280.50 T	280	140	140	18	312	73	239	165	125	110	90	50	100	-	-	-	M10	254	96	158	24

BMH 60/280.50 T - WET ROTOR CIRCULATORS

Pumped liquid temperature range: from -10 °C to +120 °C - Maximum operating pressure: 10 bar (1000 kPa)

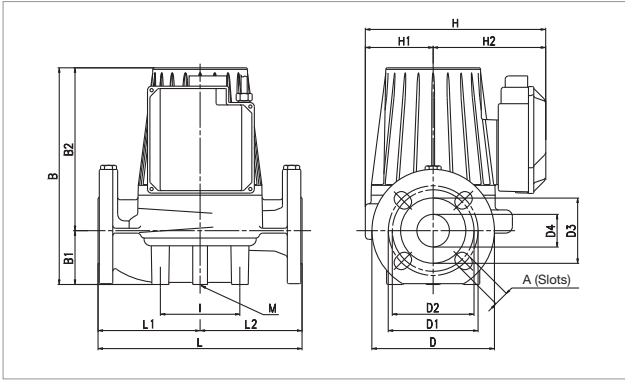

The performance curves are based on kinematic viscosity values = 1 mm²/s and density equal to 1000 kg/m³. Curve tolerance according to ISO 9906.

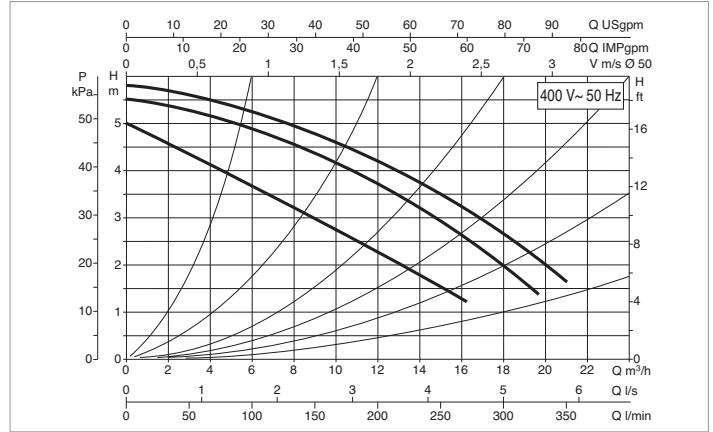

MODEL	CENTRE DISTANCE mm	COUNTERFLANGES ON REQUEST	ELECTRICAL DATA					MINIMUM SUCTION PRESSURE				
			POWER INPUT 50 Hz	SPEED	REV. 1/min	P1 MAX W	In A	t°	75°	90°	110°	120°
								m.c.w.				
BMH 60/280.50 T	280	DN 50 - PN 10	3x230 V ~	2	1210	272	0.94	m.c.w.	4	7.5	-	21
			3x400 V ~	1	1120	240	0.8					

MODEL	L	L1	L2	A	B	B1	B2	D	D1	D2	D3	D4	I	I1	I2	I3	M	H	H1	H2	WEIGHT kg
BMH 60/280.50 T	280	140	140	18	312	73	239	165	125	110	90	50	100	-	-	-	M10	254	96	158	24

BPH 60/280.50 M - WET ROTOR CIRCULATORS

Pumped liquid temperature range: from -10 °C to +110 °C - Maximum operating pressure: 10 bar (1000 kPa)

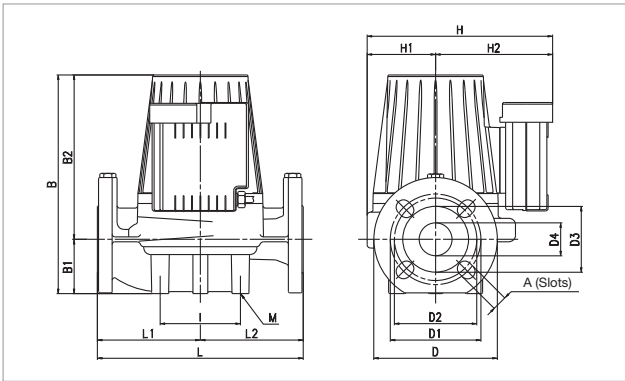

The performance curves are based on kinematic viscosity values = 1 mm²/s and density equal to 1000 kg/m³. Curve tolerance according to ISO 9906.

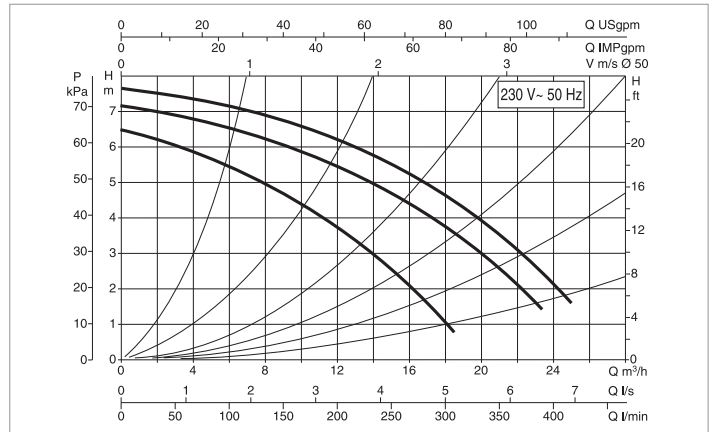

MODEL	CENTRE DISTANCE mm	COUNTERFLANGES ON REQUEST	ELECTRICAL DATA					MINIMUM SUCTION PRESSURE				
			POWER INPUT 50 Hz	SPEED	REV. 1/min	P1 MAX W	In A	t°	75°	90°	110°	120°
								m.c.w.				
BPH 60/280.50 M	280	DN 50 - PN 10	1x230 V ~	3	2840	595	2.79	m.c.w.	1.6	6	14	-
				2	2730	540	2.45					
				1	2200	506	2.58					

MODEL	L	L1	L2	A	B	B1	B2	D	D1	D2	D3	D4	I	I1	I2	I3	M	H	H1	H2	WEIGHT kg
BPH 60/280.50 M	280	140	140	18	312	73	239	165	125	110	90	50	100	-	-	-	M10	254	96	158	24

BPH 60/280.50 T - WET ROTOR CIRCULATORS

Pumped liquid temperature range: from -10 °C to +120 °C - Maximum operating pressure: 10 bar (1000 kPa)

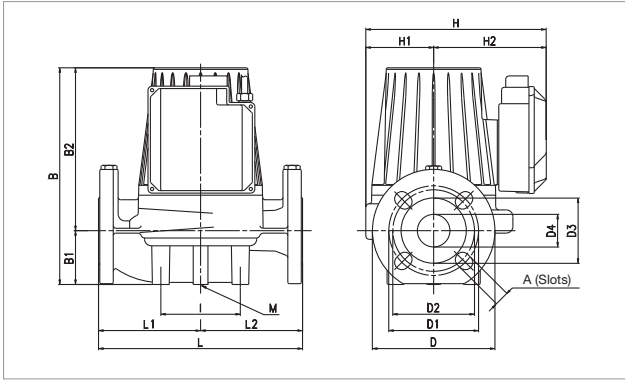

The performance curves are based on kinematic viscosity values = 1 mm²/s and density equal to 1000 kg/m³. Curve tolerance according to ISO 9906.

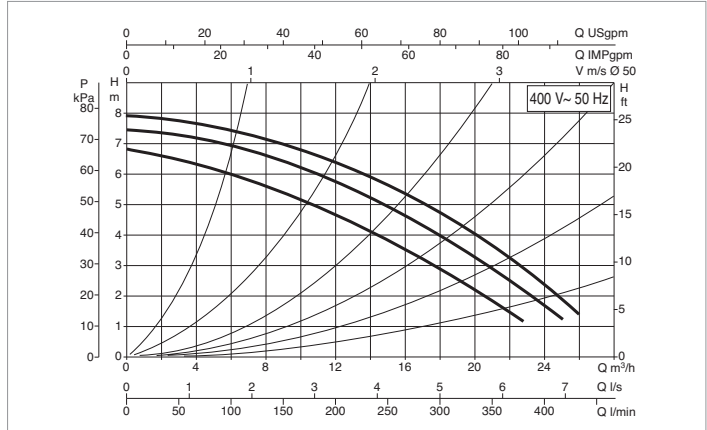

MODEL	CENTRE DISTANCE mm	COUNTERFLANGES ON REQUEST	ELECTRICAL DATA					MINIMUM SUCTION PRESSURE				
			POWER INPUT 50 Hz	SPEED	REV. 1/min	P1 MAX W	In A	t°	75°	90°	110°	120°
BPH 60/280.50 T	280	DN 50 - PN 10	3x230 V ~	2	2670	464	1.35	m.c.w.	1.6	6	-	19
			1	2570	432	1.23						
			3x400 V ~	3	2890	589	1.31					
			1	2	2860	546	1.1					
			1	1	2570	423	0.71					

MODEL	L	L1	L2	A	B	B1	B2	D	D1	D2	D3	D4	I	I1	I2	I3	M	H	H1	H2	WEIGHT kg
BPH 60/280.50 T	280	140	140	18	312	73	239	165	125	110	90	50	100	-	-	-	M10	254	96	158	24

BPH 120/280.50 M - WET ROTOR CIRCULATORS

Pumped liquid temperature range: from -10 °C to +90 °C - Maximum operating pressure: 10 bar (1000 kPa)

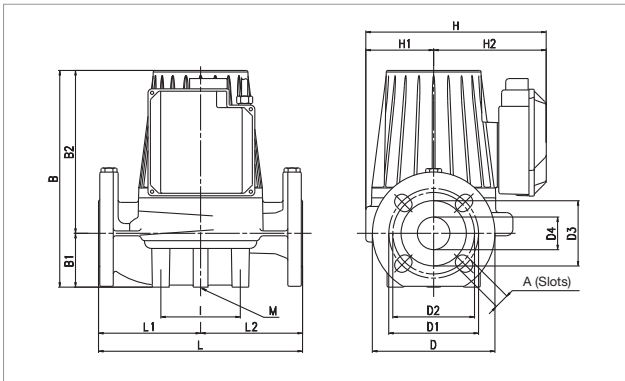

The performance curves are based on kinematic viscosity values = 1 mm²/s and density equal to 1000 kg/m³. Curve tolerance according to ISO 9906.

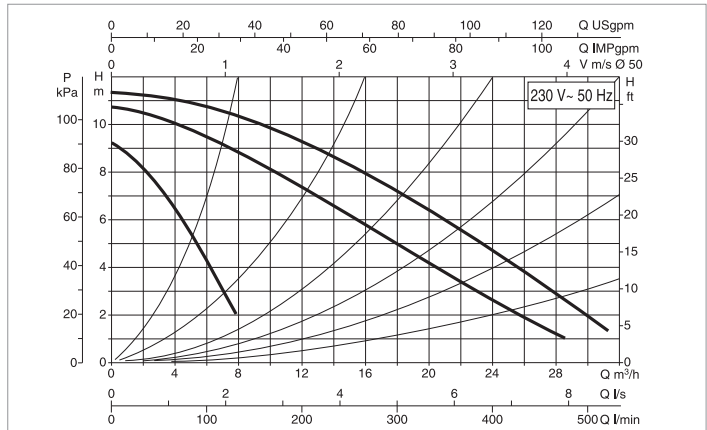

MODEL	CENTRE DISTANCE mm	COUNTERFLANGES ON REQUEST	ELECTRICAL DATA					MINIMUM SUCTION PRESSURE				
			POWER INPUT 50 Hz	SPEED	REV. 1/min	P1 MAX W	In A	t°	75°	90°	110°	120°
BPH 120/280.50 M	280	DN 50 - PN 10	1x230 V ~	3	2690	870	3.97	m.c.w.	2	5	-	20
				2	2360	800	3.69					
				1	1340	590	3.12					

MODEL	L	L1	L2	A	B	B1	B2	D	D1	D2	D3	D4	I	I1	I2	I3	M	H	H1	H2	WEIGHT kg
BPH 120/280.50 M	280	140	140	18	312	73	239	165	125	110	90	50	100	-	-	-	M10	254	96	158	24

BPH 120/280.50 T - WET ROTOR CIRCULATORS

Pumped liquid temperature range: from -10 °C to +120 °C - Maximum operating pressure: 10 bar (1000 kPa)

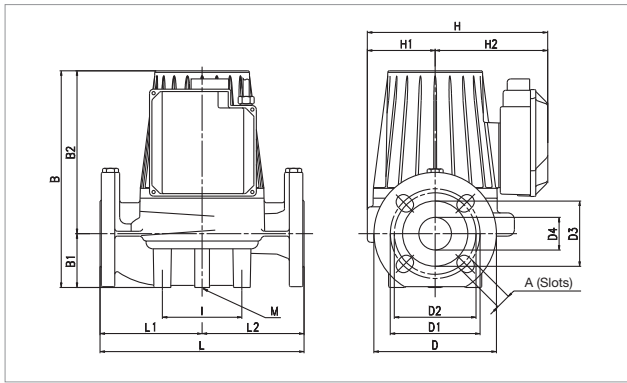

The performance curves are based on kinematic viscosity values = 1 mm²/s and density equal to 1000 kg/m³. Curve tolerance according to ISO 9906.

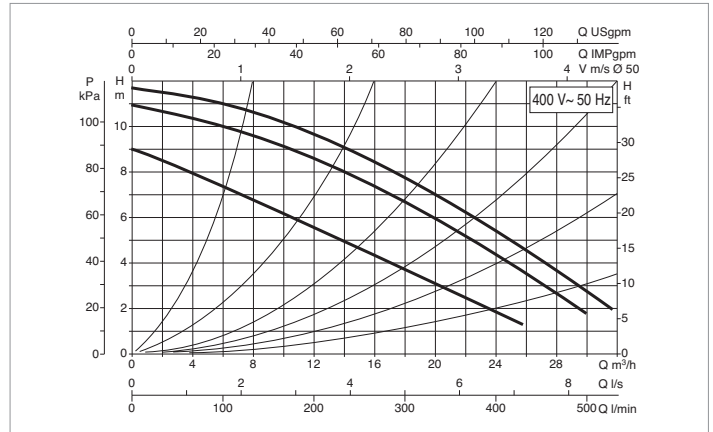

MODEL	CENTRE DISTANCE mm	COUNTERFLANGES ON REQUEST	ELECTRICAL DATA					MINIMUM SUCTION PRESSURE				
			POWER INPUT 50 Hz	SPEED	REV. 1/min	P1 MAX W	In A	t°	75°	90°	110°	120°
BPH 120/280.50 T	280	DN 50 - PN 10	3x230 V ~	2 1	2430 2240	683 605	1.95 1.75	m.c.w.	2	5	-	20
			3x400 V ~	3 2 1	2810 2740 2260	898 840 603	1.67 1.47 1					

MODEL	L	L1	L2	A	B	B1	B2	D	D1	D2	D3	D4	I	I1	I2	I3	M	H	H1	H2	WEIGHT kg
BPH 120/280.50 T	280	140	140	18	312	73	239	165	125	110	90	50	100	-	-	-	M10	254	96	158	26

BPH 150/280.50 T - WET ROTOR CIRCULATORS

Pumped liquid temperature range: from -10 °C to +110 °C - Maximum operating pressure: 10 bar (1000 kPa)

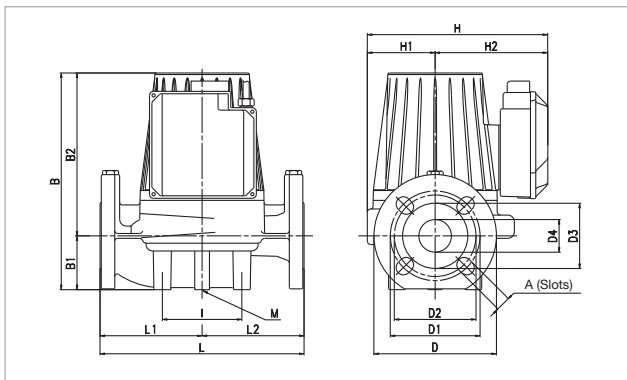

The performance curves are based on kinematic viscosity values = 1 mm²/s and density equal to 1000 kg/m³. Curve tolerance according to ISO 9906.

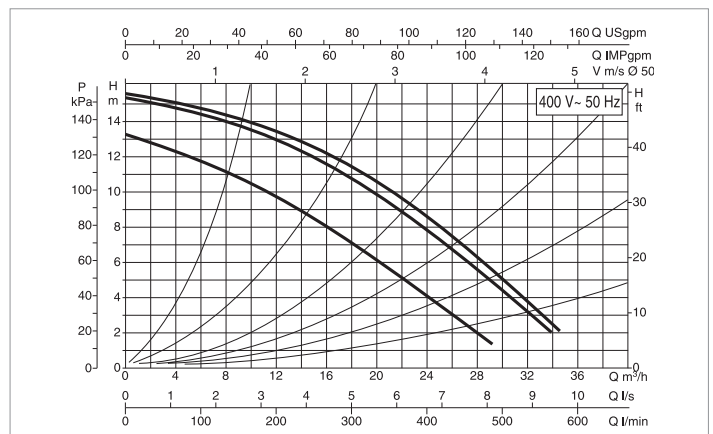

MODEL	CENTRE DISTANCE mm	COUNTERFLANGES ON REQUEST	ELECTRICAL DATA					MINIMUM SUCTION PRESSURE				
			POWER INPUT 50 Hz	SPEED	REV. 1/min	P1 MAX W	In A	t°	75°	90°	110°	120°
BPH 150/280.50 T	280	DN 50 - PN 10	3x230 V ~	2 1	2553 2420	1130 1032	3.22 3	m.c.w.	2	5	-	20
			3x400 V ~	3 2 1	2850 2802 2425	1470 1360 1030	2.9 2.5 1.7					

MODEL	L	L1	L2	A	B	B1	B2	D	D1	D2	D3	D4	I	I1	I2	I3	M	H	H1	H2	WEIGHT kg
BPH 150/280.50 T	280	140	140	18	362	73	289	165	125	110	90	50	100	-	-	-	M10	254	96	158	26

BPH 180/280.50 T - WET ROTOR CIRCULATORS

Pumped liquid temperature range: from -10 °C to +120 °C - Maximum operating pressure: 10 bar (1000 kPa)

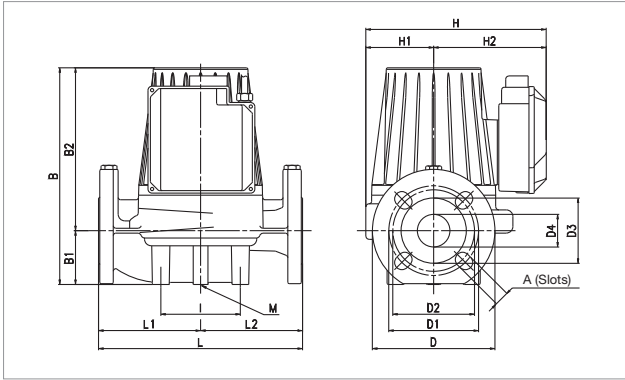

The performance curves are based on kinematic viscosity values = 1 mm²/s and density equal to 1000 kg/m³. Curve tolerance according to ISO 9906.

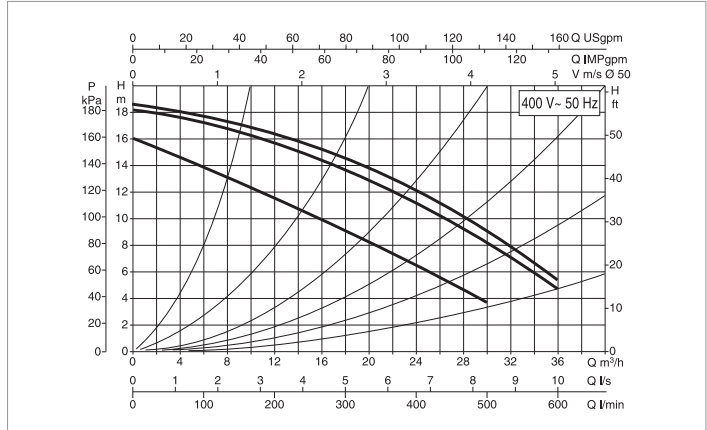

MODEL	CENTRE DISTANCE mm	COUNTERFLANGES ON REQUEST	ELECTRICAL DATA					MINIMUM SUCTION PRESSURE				
			POWER INPUT 50 Hz	SPEED	REV. 1/min	P1 MAX W	In A	t°	75°	90°	110°	120°
BPH 180/280.50 T	280	DN 50 - PN 10	3x230 V ~	2	2520	1230	3,5	m.c.w.	2	5	-	20
			3x400 V ~	1	2340	1120	3,2					
				3	2830	1630	3					
				2	2780	1540	2,70					
				1	2360	1130	1,85					

MODEL	L	L1	L2	A	B	B1	B2	D	D1	D2	D3	D4	I	I1	I2	I3	M	H	H1	H2	WEIGHT kg
BPH 180/280.50 T	280	140	140	18	362	73	289	165	125	110	90	50	100	-	-	-	M10	254	96	158	26

BMH 30/340.65 T - WET ROTOR CIRCULATORS

Pumped liquid temperature range: from -10 °C to +120 °C - Maximum operating pressure: 10 bar (1000 kPa)

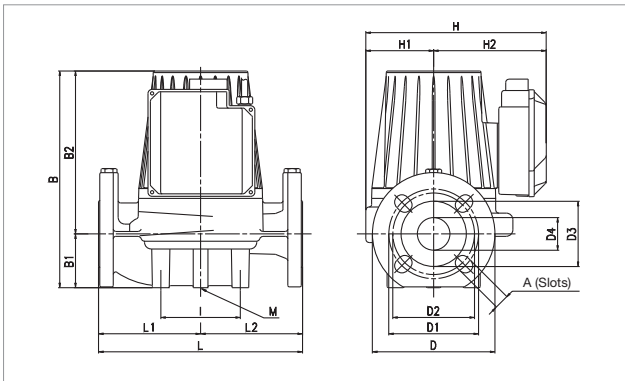

The performance curves are based on kinematic viscosity values = 1 mm²/s and density equal to 1000 kg/m³. Curve tolerance according to ISO 9906.

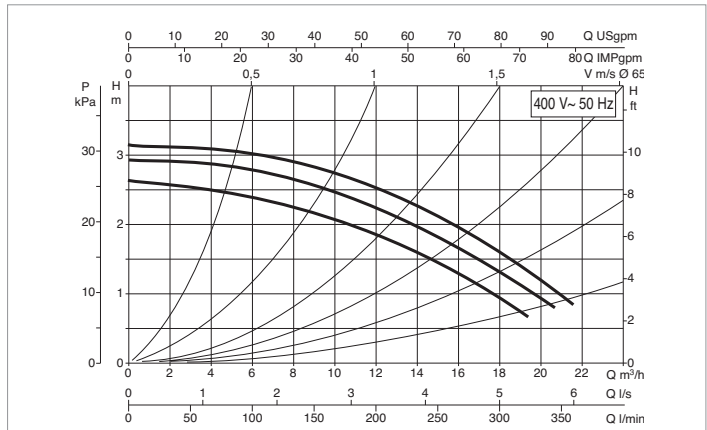

MODEL	CENTRE DISTANCE mm	COUNTERFLANGES ON REQUEST	ELECTRICAL DATA					MINIMUM SUCTION PRESSURE				
			POWER INPUT 50 Hz	SPEED	REV. 1/min	P1 MAX W	In A	t°	75°	90°	110°	120°
BMH 30/340.65 T	340	DN 65 - PN 10	3x230 V ~	2	1360	170	0,73	m.c.w.	4	7.5	-	21
			3x400 V ~	1	1310	154	0,60					
				3	1450	270	1,12					
				2	1430	233	0,84					
				1	1310	150	0,35					

MODEL	L	L1	L2	A	B	B1	B2	D	D1	D2	D3	D4	I	I1	I2	I3	M	H	H1	H2	WEIGHT kg
BMH 30/340.65 T	340	170	170	18	334	82	252	185	145	130	110	65	100	-	-	-	M12	259	100	159	27,5

BMH 60/340.65 T - WET ROTOR CIRCULATORS

Pumped liquid temperature range: from -10 °C to +120 °C - Maximum operating pressure: 10 bar (1000 kPa)

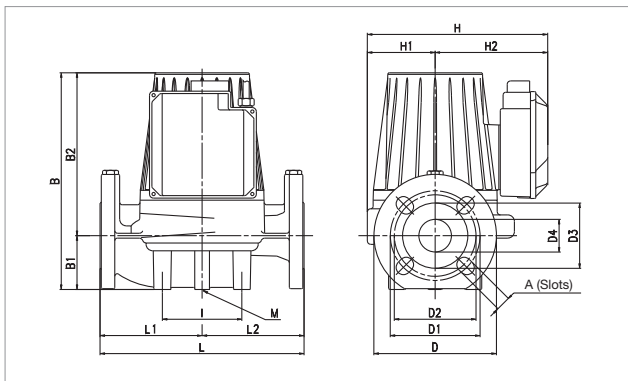

The performance curves are based on kinematic viscosity values = 1 mm²/s and density equal to 1000 kg/m³. Curve tolerance according to ISO 9906.

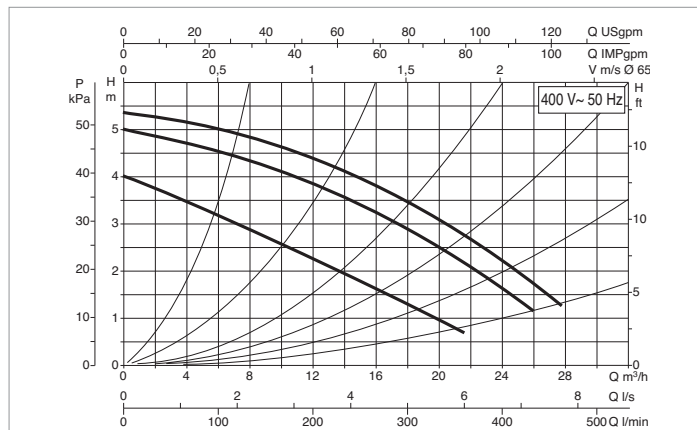

MODEL	CENTRE DISTANCE mm	COUNTERFLANGES ON REQUEST	ELECTRICAL DATA					MINIMUM SUCTION PRESSURE				
			POWER INPUT 50 Hz	SPEED	REV. 1/min	P1 MAX W	In A	t°	75°	90°	110°	120°
								m.c.w.	4	7.5	-	21
BMH 60/340.65 T	340	DN 65 - PN 10	3x230 V ~	2	1170	295	1	m.c.w.	4	7.5	-	21
			3x400 V ~	1	1070	257	0.85					

MODEL	L	L1	L2	A	B	B1	B2	D	D1	D2	D3	D4	I	I1	I2	I3	M	H	H1	H2	WEIGHT kg
BMH 60/340.65 T	340	170	170	18	334	82	252	185	145	130	110	65	100	-	-	-	M12	259	100	159	27,5

BPH 60/340.65 M - WET ROTOR CIRCULATORS

Pumped liquid temperature range: from -10 °C to +110 °C - Maximum operating pressure: 10 bar (1000 kPa)

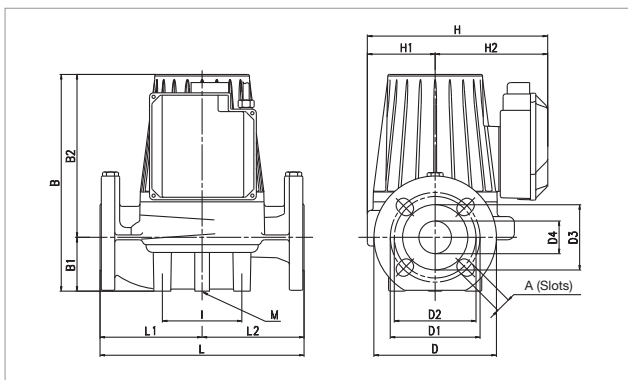

The performance curves are based on kinematic viscosity values = 1 mm²/s and density equal to 1000 kg/m³. Curve tolerance according to ISO 9906.

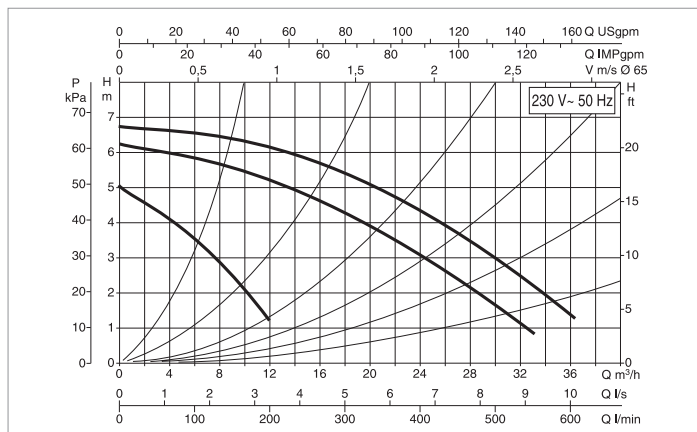

MODEL	CENTRE DISTANCE mm	COUNTERFLANGES ON REQUEST	ELECTRICAL DATA					MINIMUM SUCTION PRESSURE				
			POWER INPUT 50 Hz	SPEED	REV. 1/min	P1 MAX W	In A	t°	75°	90°	110°	120°
								m.c.w.	1	4	13	-
BPH 60/340.65 M	340	DN 65 - PN 10	1x230 V ~	3	2780	735	3.37	m.c.w.	1	4	13	-
				2	2580	685	3.13					
				1	1460	564	3.12					

MODEL	L	L1	L2	A	B	B1	B2	D	D1	D2	D3	D4	I	I1	I2	I3	M	H	H1	H2	WEIGHT kg
BPH 60/340.65 M	340	170	170	18	334	82	252	185	145	130	110	65	100	-	-	-	M12	259	100	159	27,5

BPH 60/340.65 T - WET ROTOR CIRCULATORS

Pumped liquid temperature range: from -10 °C to +120 °C - Maximum operating pressure: 10 bar (1000 kPa)

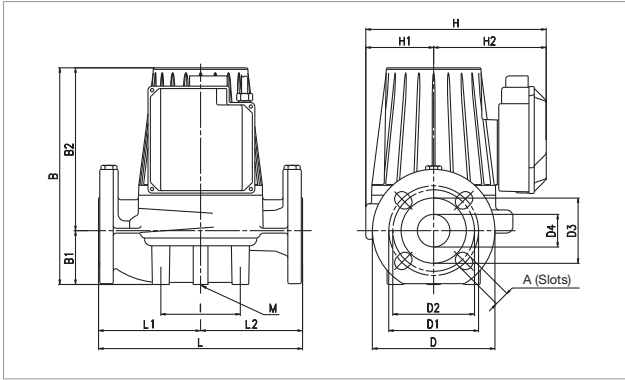

The performance curves are based on kinematic viscosity values = 1 mm²/s and density equal to 1000 kg/m³. Curve tolerance according to ISO 9906.

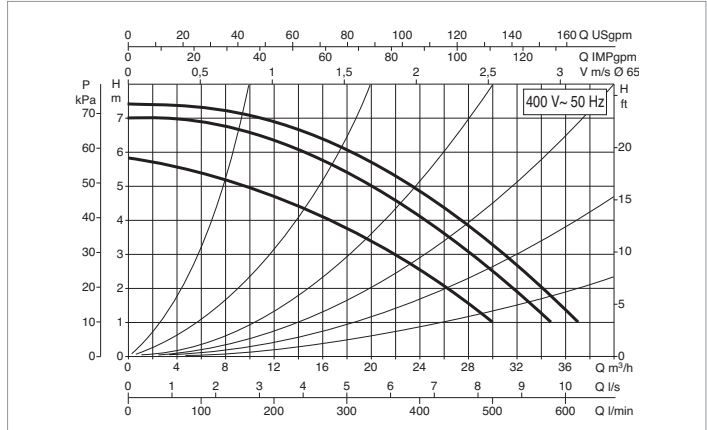

MODEL	CENTRE DISTANCE mm	COUNTERFLANGES ON REQUEST	ELECTRICAL DATA					MINIMUM SUCTION PRESSURE				
			POWER INPUT 50 Hz	SPEED	REV. 1/min	P1 MAX W	In A	t°	75°	90°	110°	120°
BPH 60/340.65 T	340	DN 65 - PN 10	3x230 V ~	2	2550	582	1.67	m.c.w.	1	4	-	18
			1	2380	532	1.53						
BPH 60/340.65 T	340	DN 65 - PN 10	3x400 V ~	3	2850	756	1.5	m.c.w.	1	4	-	18
			2	2800	705	1.3						
			1	2400	535	0.9						

MODEL	L	L1	L2	A	B	B1	B2	D	D1	D2	D3	D4	I	I1	I2	I3	M	H	H1	H2	WEIGHT kg
BPH 60/340.65 T	340	170	170	18	334	82	252	185	145	130	110	65	100	-	-	-	M12	259	100	159	30,5

BPH 120/340.65 T - WET ROTOR CIRCULATORS

Pumped liquid temperature range: from -10 °C to +120 °C - Maximum operating pressure: 10 bar (1000 kPa)

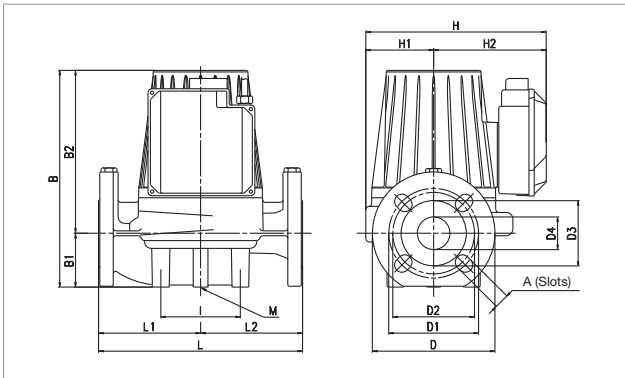

The performance curves are based on kinematic viscosity values = 1 mm²/s and density equal to 1000 kg/m³. Curve tolerance according to ISO 9906.

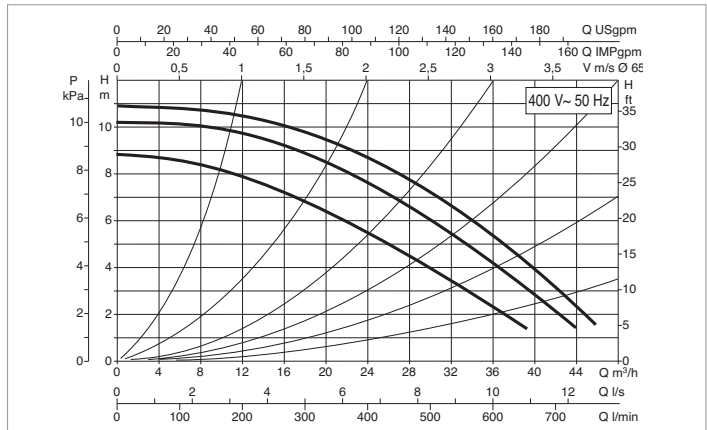

MODEL	CENTRE DISTANCE mm	COUNTERFLANGES ON REQUEST	ELECTRICAL DATA					MINIMUM SUCTION PRESSURE				
			POWER INPUT 50 Hz	SPEED	REV. 1/min	P1 MAX W	In A	t°	75°	90°	110°	120°
BPH 120/340.65 T	340	DN 65 - PN 10	3x230 V ~	2	2630	1001	2.85	m.c.w.	6	9	-	22
			1	2500	940	2.66						
BPH 120/340.65 T	340	DN 65 - PN 10	3x400 V ~	3	2880	1275	2.64	m.c.w.	6	9	-	22
			2	2830	1200	2.25						
			1	2520	934	1.52						

MODEL	L	L1	L2	A	B	B1	B2	D	D1	D2	D3	D4	I	I1	I2	I3	M	H	H1	H2	WEIGHT kg
BPH 120/340.65 T	340	170	170	18	384	82	302	185	145	130	110	65	100	-	-	-	M12	259	100	159	32,5

BPH 150/340.65 T - WET ROTOR CIRCULATORS

Pumped liquid temperature range: from -10 °C to +110 °C - Maximum operating pressure: 10 bar (1000 kPa)

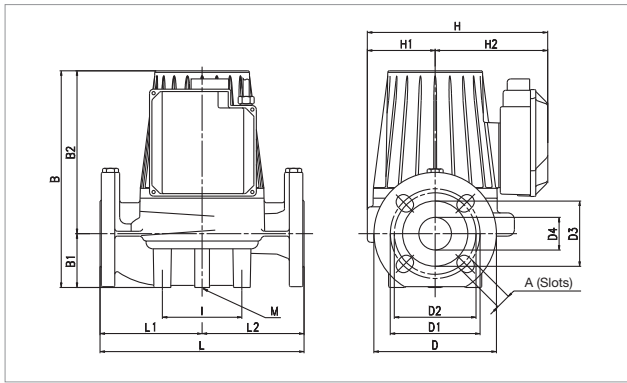

The performance curves are based on kinematic viscosity values = 1 mm²/s and density equal to 1000 kg/m³. Curve tolerance according to ISO 9906.

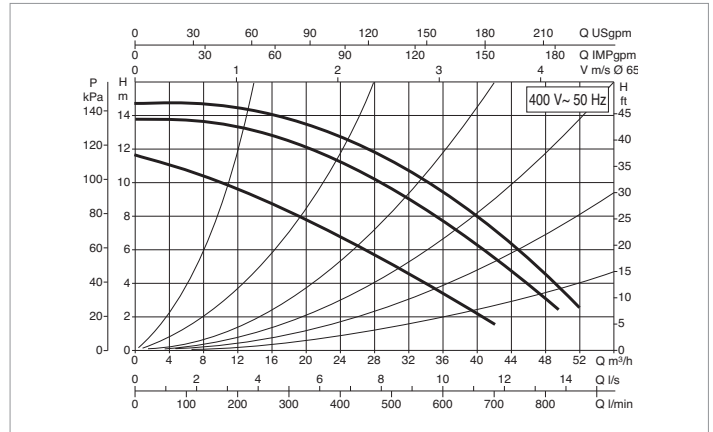

MODEL	CENTRE DISTANCE mm	COUNTERFLANGES ON REQUEST	ELECTRICAL DATA					MINIMUM SUCTION PRESSURE				
			POWER INPUT 50 Hz	SPEED	REV. 1/min	P1 MAX W	In A	t°	75°	90°	110°	120°
BPH 150/340.65 T	340	DN 65 - PN 10	3x230 V ~	2	2410	1345	3.8	m.c.w.	7	11	18	-
			1	2250	1188	3.36						
			3x400 V ~	3	2800	1796	3.25					
			2	2730	1690	2.93						
			1	2250	1210	2						

MODEL	L	L1	L2	A	B	B1	B2	D	D1	D2	D3	D4	I	I1	I2	I3	M	H	H1	H2	WEIGHT kg
BPH 150/340.65 T	340	170	170	18	384	82	302	185	145	130	110	65	100	-	-	-	M12	259	100	159	32,5

BPH 180/340.65 T - WET ROTOR CIRCULATORS

Pumped liquid temperature range: from -10 °C to +110 °C - Maximum operating pressure: 10 bar (1000 kPa)

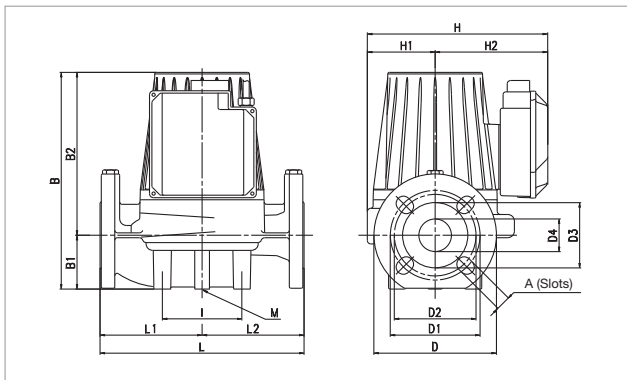

The performance curves are based on kinematic viscosity values = 1 mm²/s and density equal to 1000 kg/m³. Curve tolerance according to ISO 9906.

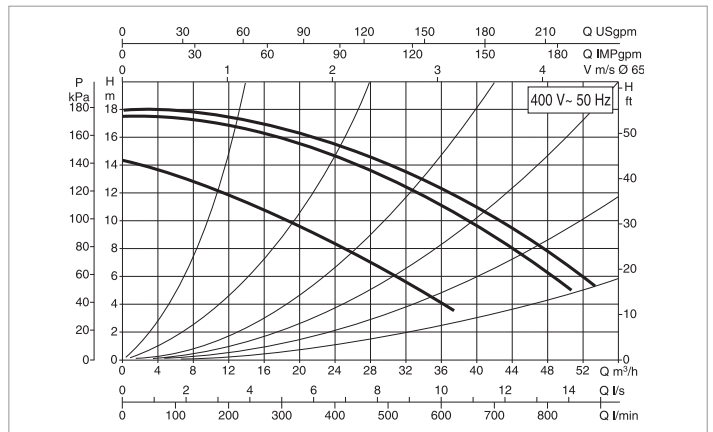

MODEL	CENTRE DISTANCE mm	COUNTERFLANGES ON REQUEST	ELECTRICAL DATA					MINIMUM SUCTION PRESSURE				
			POWER INPUT 50 Hz	SPEED	REV. 1/min	P1 MAX W	In A	t°	75°	90°	110°	120°
BPH 180/340.65 T	340	DN 65 - PN 10	3x230 V ~	2	2380	1670	4,7	m.c.w.	7	11	18	-
			1	2170	1490	4,25						
			3x400 V ~	3	2780	2310	4					
			2	2700	2210	3,5						
			1	2200	1490	2,4						

MODEL	L	L1	L2	A	B	B1	B2	D	D1	D2	D3	D4	I	I1	I2	I3	M	H	H1	H2	WEIGHT kg
BPH 180/340.65 T	340	170	170	18	384	82	302	185	145	130	110	65	100	-	-	-	M12	259	100	159	32,5

BMH 30/360.80 T - WET ROTOR CIRCULATORS

Pumped liquid temperature range: from -10 °C to +120 °C - Maximum operating pressure: 10 bar (1000 kPa)

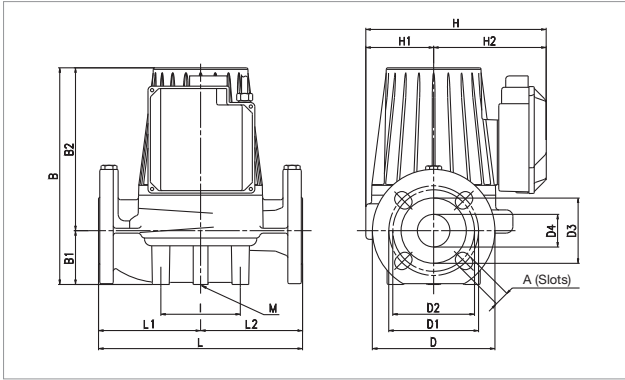

The performance curves are based on kinematic viscosity values = 1 mm²/s and density equal to 1000 kg/m³. Curve tolerance according to ISO 9906.

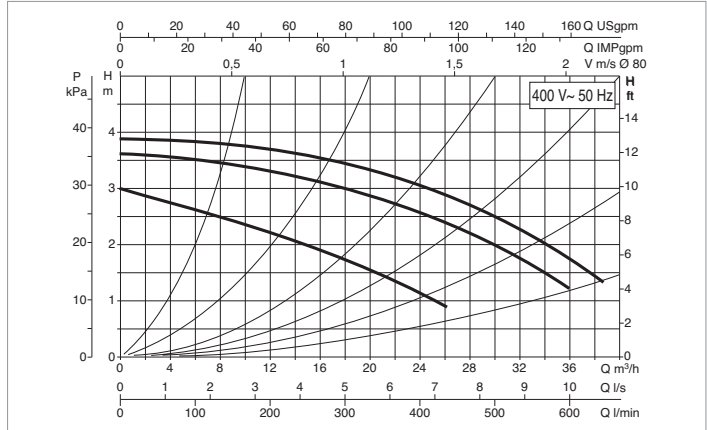

MODEL	CENTRE DISTANCE mm	COUNTERFLANGES ON REQUEST	ELECTRICAL DATA					MINIMUM SUCTION PRESSURE				
			POWER INPUT 50 Hz	SPEED	REV. 1/min	P1 MAX W	In A	t°	75°	90°	110°	120°
BMH 30/360.80 T	360	DN 80 - PN 10	3x230 V ~	2	1110	313	1.05	m.c.w.	4	7.5	-	21
			3x400 V ~	1	1010	268	0.88					
				3	1370	484	1.23					
				2	1330	437	1					
				1	1030	266	0.51					

MODEL	L	L1	L2	A	B	B1	B2	D	D1	D2	D3	D4	I	I1	I2	I3	M	H	H1	H2	WEIGHT kg
BMH 30/360.80 T	360	170	190	18	354	97	254	200	160	150	130	80	115	-	-	-	M12	297	100	159	31

BMH 60/360.80 T - WET ROTOR CIRCULATORS

Pumped liquid temperature range: from -10 °C to +110 °C - Maximum operating pressure: 10 bar (1000 kPa)

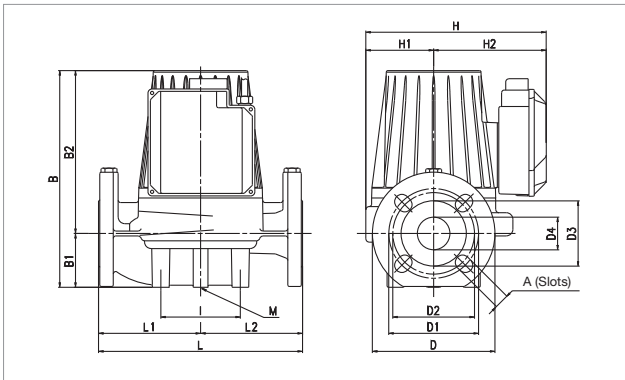

The performance curves are based on kinematic viscosity values = 1 mm²/s and density equal to 1000 kg/m³. Curve tolerance according to ISO 9906.

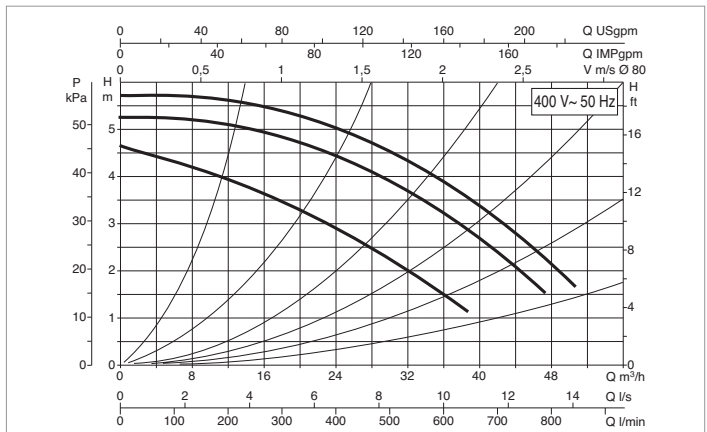

MODEL	CENTRE DISTANCE mm	COUNTERFLANGES ON REQUEST	ELECTRICAL DATA					MINIMUM SUCTION PRESSURE				
			POWER INPUT 50 Hz	SPEED	REV. 1/min	P1 MAX W	In A	t°	75°	90°	110°	120°
BMH 60/360.80 T	360	DN 80 - PN 10	3x230 V ~	2	1180	535	1.82	m.c.w.	2	5	-	20
			3x400 V ~	1	1100	465	1.55					
				3	1390	763	2.04					
				2	1350	663	1.65					
				1	1100	465	0.89					

MODEL	L	L1	L2	A	B	B1	B2	D	D1	D2	D3	D4	I	I1	I2	I3	M	H	H1	H2	WEIGHT kg
BMH 60/360.80 T	360	170	190	18	404	97	307	200	160	150	130	80	115	-	-	-	M12	259	100	159	40

BPH 120/360.80 T - WET ROTOR CIRCULATORS

Pumped liquid temperature range: from -10 °C to +120 °C - Maximum operating pressure: 10 bar (1000 kPa)

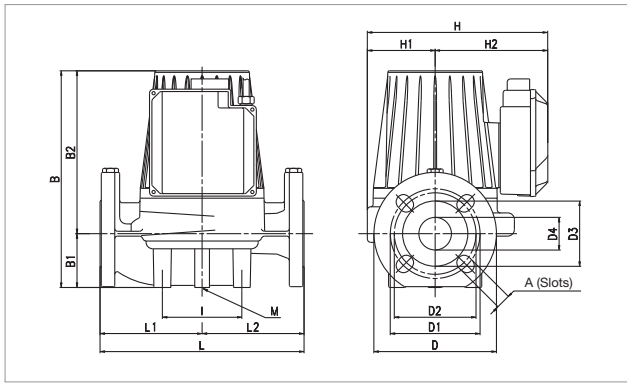

The performance curves are based on kinematic viscosity values = 1 mm²/s and density equal to 1000 kg/m³. Curve tolerance according to ISO 9906.

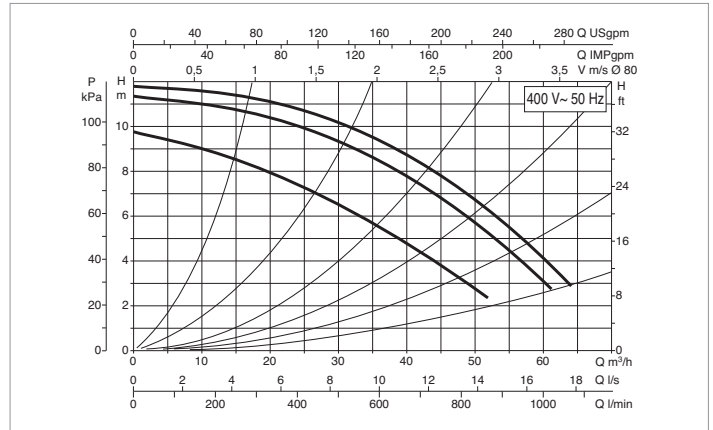

MODEL	CENTRE DISTANCE mm	COUNTERFLANGES ON REQUEST	ELECTRICAL DATA					MINIMUM SUCTION PRESSURE				
			POWER INPUT 50 Hz	SPEED	REV. 1/min	P1 MAX W	In A	t°	75°	90°	110°	120°
BPH 120/360.80 T	360	DN 80 - PN 10	3x230 V ~	2 1	2500 2340	1410 1292	3.95 3.6	m.c.w.	6	10	-	22
			3x400 V ~	3 2 1	2830 2780 2350	1820 1710 1302	3.3 2.93 2.13					

MODEL	L	L1	L2	A	B	B1	B2	D	D1	D2	D3	D4	I	I1	I2	I3	M	H	H1	H2	WEIGHT kg
BPH 120/360.80 T	360	170	190	18	404	97	307	200	160	150	130	80	115	-	-	-	M12	259	100	159	40

BPH 150/360.80 T - WET ROTOR CIRCULATORS

Pumped liquid temperature range: from -10 °C to +110 °C - Maximum operating pressure: 10 bar (1000 kPa)

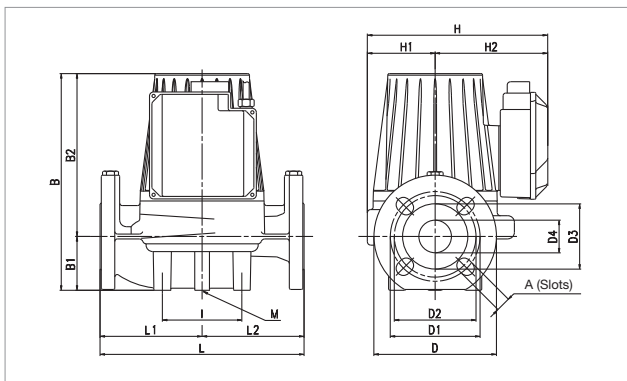

The performance curves are based on kinematic viscosity values = 1 mm²/s and density equal to 1000 kg/m³. Curve tolerance according to ISO 9906.

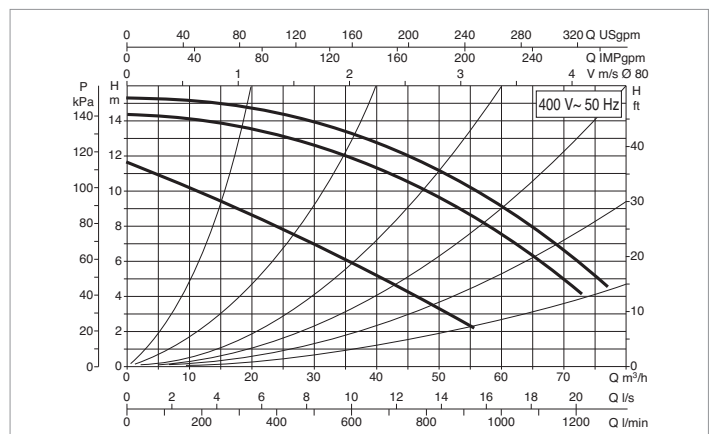

MODEL	CENTRE DISTANCE mm	COUNTERFLANGES ON REQUEST	ELECTRICAL DATA					MINIMUM SUCTION PRESSURE				
			POWER INPUT 50 Hz	SPEED	REV. 1/min	P1 MAX W	In A	t°	75°	90°	110°	120°
BPH 150/360.80 T	360	DN 80 - PN 10	3x230 V ~	2 1	2140 1900	1984 1695	5.62 4.82	m.c.w.	7	11	18	-
			3x400 V ~	3 2 1	2710 2610 1940	2870 2686 1710	4.64 4.32 2.85					

MODEL	L	L1	L2	A	B	B1	B2	D	D1	D2	D3	D4	I	I1	I2	I3	M	H	H1	H2	WEIGHT kg
BPH 150/360.80 T	360	170	190	18	404	97	307	200	160	150	130	80	115	-	-	-	M12	259	100	159	40

* model available for all markets

BPH 180/360.80 T - WET ROTOR CIRCULATORS

Pumped liquid temperature range: from -10 °C to +110 °C - Maximum operating pressure: 10 bar (1000 kPa)

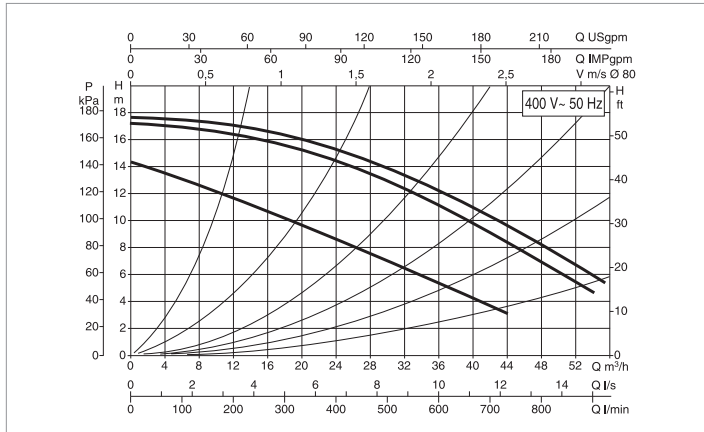
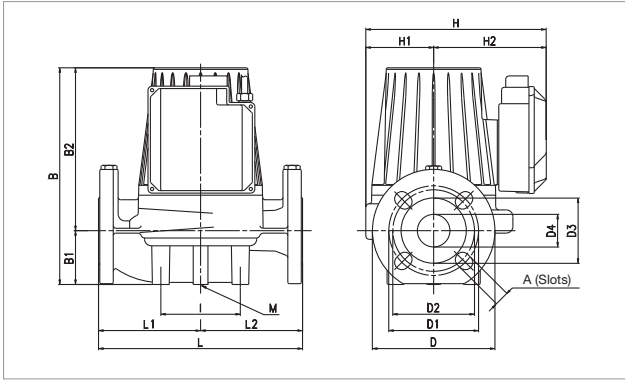

The performance curves are based on kinematic viscosity values = 1 mm²/s and density equal to 1000 kg/m³. Curve tolerance according to ISO 9906.

MODEL	CENTRE DISTANCE mm	COUNTERFLANGES ON REQUEST	ELECTRICAL DATA					MINIMUM SUCTION PRESSURE				
			POWER INPUT 50 Hz	SPEED	REV. 1/min	P1 MAX W	In A	t°	75°	90°	110°	120°
BPH 180/360.80 T	360	DN 80 - PN 10	3x230 V ~	2	2380	1670	4,7	m.c.w.	7	11	18	-
			1	2170	1490	4,25						
			3x400 V ~	3	2780	2310	4					
			2	2700	2210	3,5						
			1	2200	1490	2,4						

MODEL	L	L1	L2	A	B	B1	B2	D	D1	D2	D3	D4	I	I1	I2	I3	M	H	H1	H2	WEIGHT kg
BPH 180/360.80 T	360	170	190	18	404	97	307	200	160	150	130	80	115	-	-	-	M12	259	100	159	40

DMH 30/250.40 T - WET ROTOR CIRCULATORS

Pumped liquid temperature range: from -10 °C to +120 °C - Maximum operating pressure: 10 bar (1000 kPa)

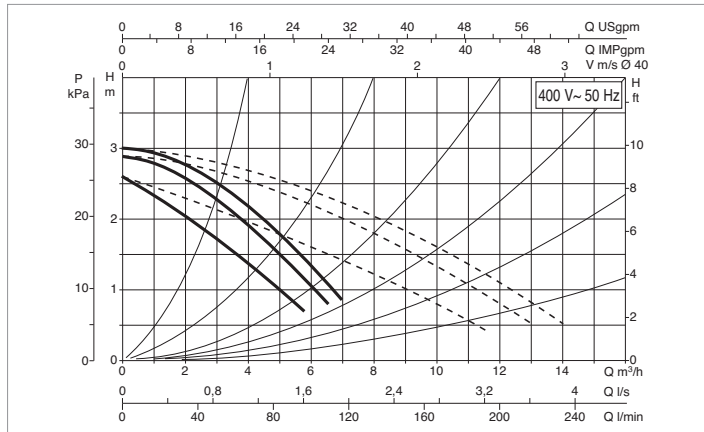
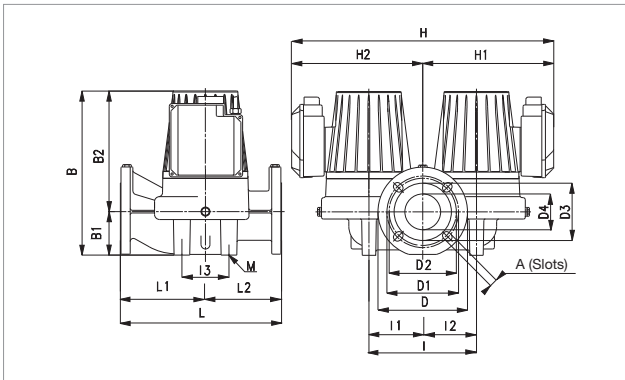

The performance curves are based on kinematic viscosity values = 1 mm²/s and density equal to 1000 kg/m³. Curve tolerance according to ISO 9906.

MODEL	CENTRE DISTANCE mm	COUNTERFLANGES ON REQUEST	ELECTRICAL DATA					MINIMUM SUCTION PRESSURE				
			POWER INPUT 50 Hz	SPEED	REV. 1/min	P1 MAX W	In A	t°	75°	90°	110°	120°
DMH 30/250.40 T	250	DN 40 - PN 10	3x230 V ~	2	1340	100	0,48	m.c.w.	0,9	4	-	18
			1	1260	88	0,39						
			3x400 V ~	3	1440	192	0,78					
			2	1430	155	0,58						
			1	1260	88	0,23						

MODEL	L	L1	L2	A	B	B1	B2	D	D1	D2	D3	D4	I	I1	I2	I3	M	H	H1	H2	WEIGHT kg
DMH 30/250.40 T	250	105	145	18	271	66	205	150	110	100	80	40	200	100	100	100	M12	476	238	238	32

DPH 60/250.40 M - WET ROTOR CIRCULATORS

Pumped liquid temperature range: from -10 °C to +110 °C - Maximum operating pressure: 10 bar (1000 kPa)

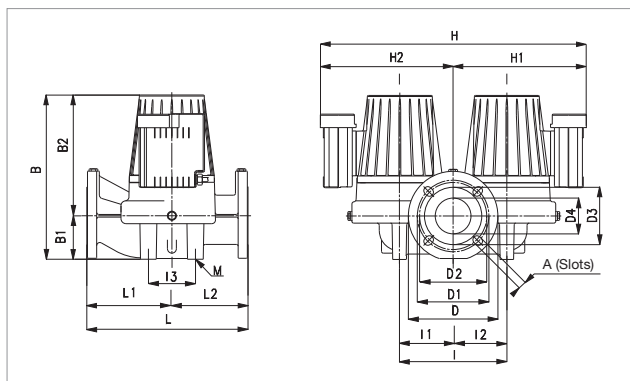

The performance curves are based on kinematic viscosity values = 1 mm²/s and density equal to 1000 kg/m³. Curve tolerance according to ISO 9906.

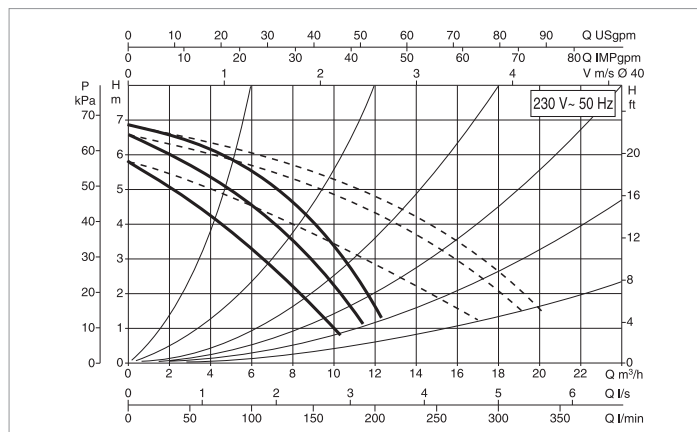

MODEL	CENTRE DISTANCE mm	COUNTERFLANGES ON REQUEST	ELECTRICAL DATA					MINIMUM SUCTION PRESSURE				
			POWER INPUT 50 Hz	SPEED	REV. 1/min	P1 MAX W	In A	t°	75°	90°	110°	120°
DPH 60/250.40 M	250	DN 40 - PN 10	1x230 V ~	3	2830	316	1.43	m.c.w.	1.6	4	14	-
				2	2750	309	1.53					
				1	2410	292	1.51					

MODEL	L	L1	L2	A	B	B1	B2	D	D1	D2	D3	D4	I	I1	I2	I3	M	H	H1	H2	WEIGHT kg
DPH 60/250.40 M	250	105	145	18	271	66	205	150	110	100	80	40	200	100	100	100	M12	476	238	238	32

DPH 60/250.40 T - WET ROTOR CIRCULATORS

Pumped liquid temperature range: from -10 °C to +120 °C - Maximum operating pressure: 10 bar (1000 kPa)

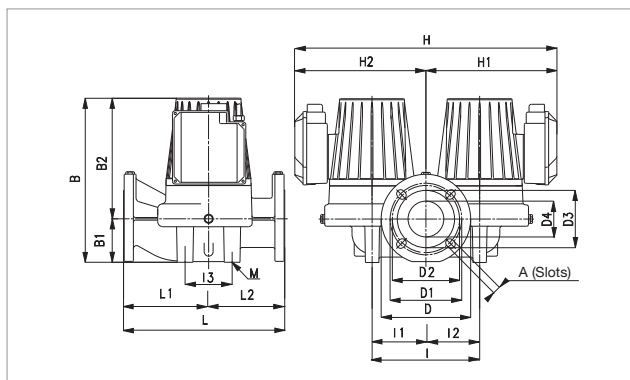

The performance curves are based on kinematic viscosity values = 1 mm²/s and density equal to 1000 kg/m³. Curve tolerance according to ISO 9906.

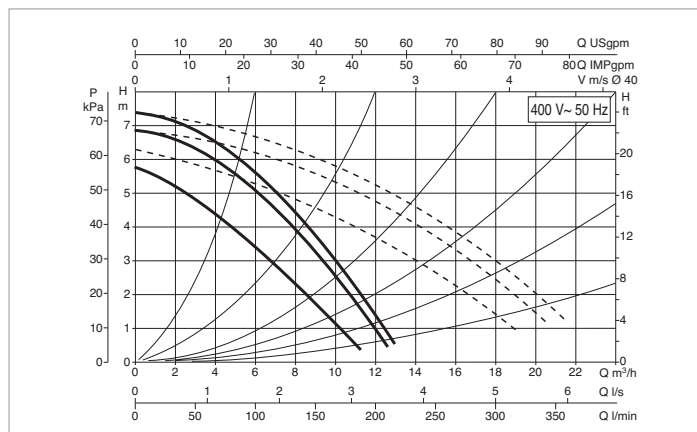

MODEL	CENTRE DISTANCE mm	COUNTERFLANGES ON REQUEST	ELECTRICAL DATA					MINIMUM SUCTION PRESSURE				
			POWER INPUT 50 Hz	SPEED	REV. 1/min	P1 MAX W	In A	t°	75°	90°	110°	120°
DPH 60/250.40 T	250	DN 40 - PN 10	3x230 V ~	2	2570	253	0.81	m.c.w.	1.6	4	-	19
				1	2420	229	0.72					
				3	2850	348	0.99					
				2	2810	316	0.75					
				1	2430	232	0.42					

MODEL	L	L1	L2	A	B	B1	B2	D	D1	D2	D3	D4	I	I1	I2	I3	M	H	H1	H2	WEIGHT kg
DPH 60/250.40 T	250	105	145	18	271	66	205	150	110	100	80	40	200	100	100	100	M12	476	238	238	32

DPH 120/250.40 M - WET ROTOR CIRCULATORS

Pumped liquid temperature range: from -10 °C to +110 °C - Maximum operating pressure: 10 bar (1000 kPa)

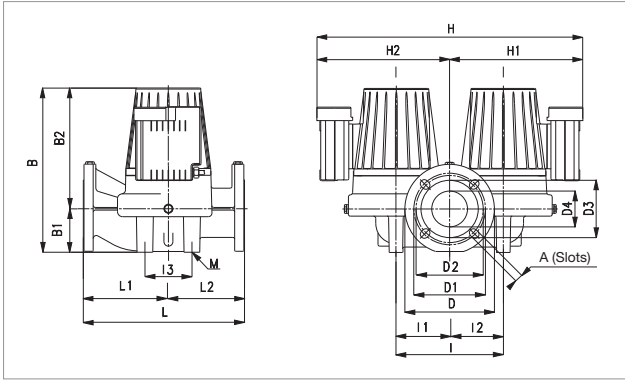

The performance curves are based on kinematic viscosity values = 1 mm²/s and density equal to 1000 kg/m³. Curve tolerance according to ISO 9906.

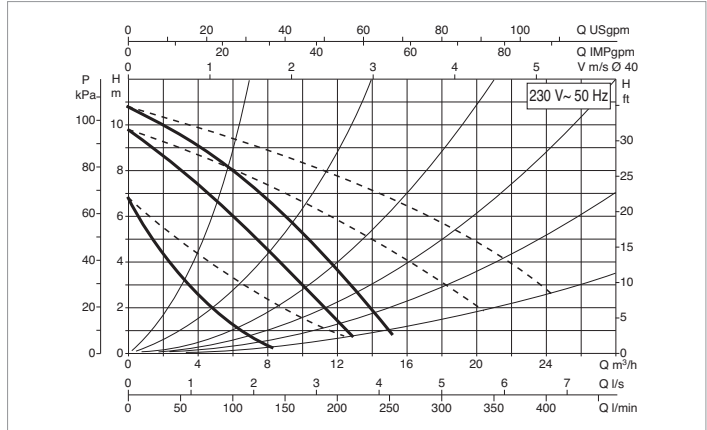

MODEL	CENTRE DISTANCE mm	COUNTERFLANGES ON REQUEST	ELECTRICAL DATA					MINIMUM SUCTION PRESSURE				
			POWER INPUT 50 Hz	SPEED	REV. 1/min	P1 MAX W	In A	t°	75°	90°	110°	120°
DPH 120/250.40 M	250	DN 40 - PN 10	1x230 V ~	3 2 1	2650 2320 1520	510 498 376	2.24 2.35 1.96	m.c.w.	6	9	18	-

MODEL	L	L1	L2	A	B	B1	B2	D	D1	D2	D3	D4	I	I1	I2	I3	M	H	H1	H2	WEIGHT kg
DPH 120/250.40 M	250	105	145	18	271	66	205	150	110	100	80	40	200	100	100	100	M12	476	238	238	32

DPH 120/250.40 T - WET ROTOR CIRCULATORS

Pumped liquid temperature range: from -10 °C to +120 °C - Maximum operating pressure: 10 bar (1000 kPa)

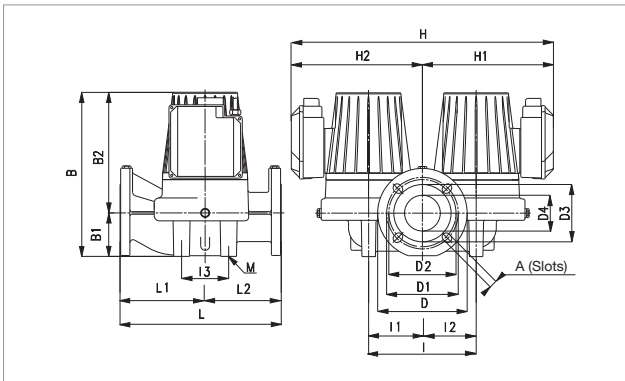

The performance curves are based on kinematic viscosity values = 1 mm²/s and density equal to 1000 kg/m³. Curve tolerance according to ISO 9906.

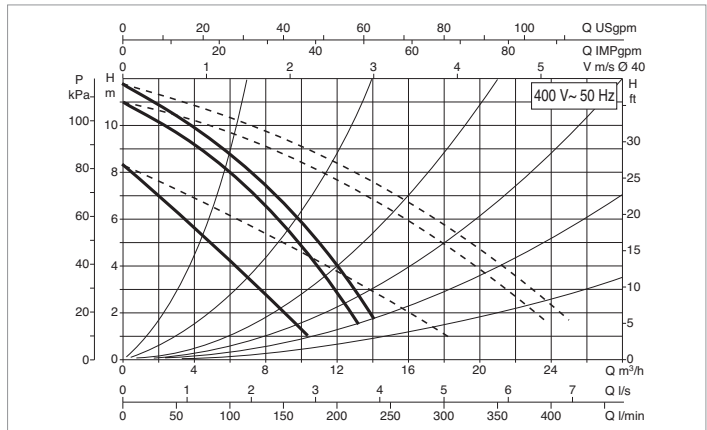

MODEL	CENTRE DISTANCE mm	COUNTERFLANGES ON REQUEST	ELECTRICAL DATA					MINIMUM SUCTION PRESSURE				
			POWER INPUT 50 Hz	SPEED	REV. 1/min	P1 MAX W	In A	t°	75°	90°	110°	120°
DPH 120/250.40 T	250	DN 40 - PN 10	3x230 V ~	2 1	2300 2070	395 340	1.2 1.07	m.c.w.	6	9	-	23
			3x400 V ~	3 2 1	2780 2710 2080	536 499 339	1.16 0.98 0.62					

MODEL	L	L1	L2	A	B	B1	B2	D	D1	D2	D3	D4	I	I1	I2	I3	M	H	H1	H2	WEIGHT kg
DPH 120/250.40 T	250	105	145	18	271	66	205	150	110	100	80	40	200	100	100	100	M12	476	238	238	32

DMH 30/280.50 T - WET ROTOR CIRCULATORS

Pumped liquid temperature range: from -10 °C to +120 °C - Maximum operating pressure: 10 bar (1000 kPa)

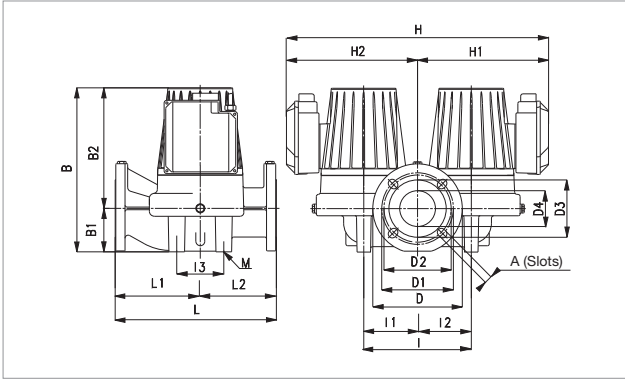

The performance curves are based on kinematic viscosity values = 1 mm²/s and density equal to 1000 kg/m³. Curve tolerance according to ISO 9906.

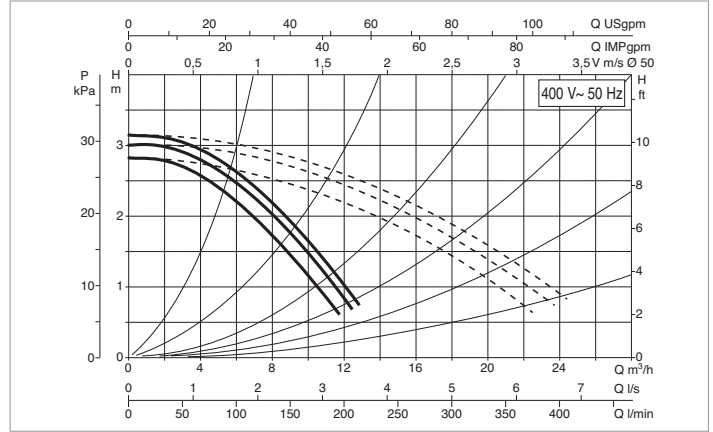

MODEL	CENTRE DISTANCE mm	COUNTERFLANGES ON REQUEST	ELECTRICAL DATA					MINIMUM SUCTION PRESSURE				
			POWER INPUT 50 Hz	SPEED	REV. 1/min	P1 MAX W	In A	t°	75°	90°	110°	120°
								m.c.w.	0.9	4	-	18
DMH 30/280.50 T	280	DN 50 - PN 10	3x230 V ~	2	1390	148	0.7					
				1	1340	134	0.55					
			3x400 V ~	3	1460	255	1.12					
				2	1450	216	0.83					
				1	1350	131	0.32					

MODEL	L	L1	L2	A	B	B1	B2	D	D1	D2	D3	D4	I	I1	I2	I3	M	H	H1	H2	WEIGHT kg
DMH 30/280.50 T	280	130	150	18	305	73	232	165	125	110	90	50	240	120	120	120	M14	552	276	276	51,5

DMH 60/280.50 T - WET ROTOR CIRCULATORS

Pumped liquid temperature range: from -10 °C to +120 °C - Maximum operating pressure: 10 bar (1000 kPa)

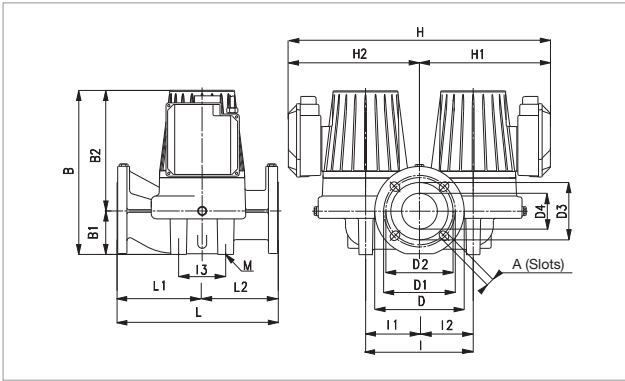

The performance curves are based on kinematic viscosity values = 1 mm²/s and density equal to 1000 kg/m³. Curve tolerance according to ISO 9906.

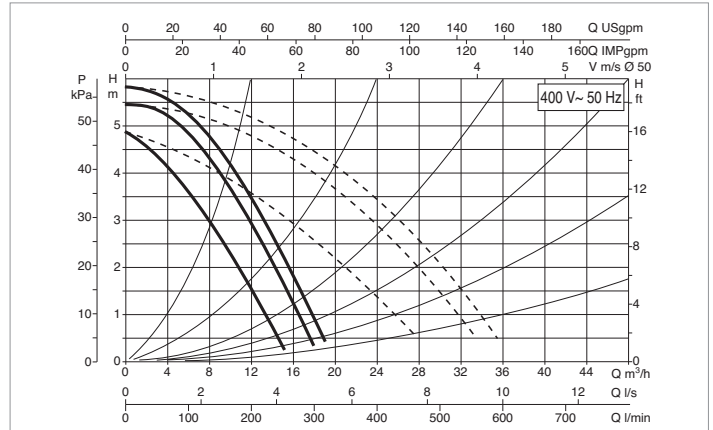

MODEL	CENTRE DISTANCE mm	COUNTERFLANGES ON REQUEST	ELECTRICAL DATA					MINIMUM SUCTION PRESSURE				
			POWER INPUT 50 Hz	SPEED	REV. 1/min	P1 MAX W	In A	t°	75°	90°	110°	120°
								m.c.w.	4	7.5	-	21
DMH 60/280.50 T	280	DN 50 - PN 10	3x230 V ~	2	1210	272	0.94					
				1	1120	240	0.8					
			3x400 V ~	3	1400	410	1.2					
				2	1360	367	0.95					
				1	1130	235	0.46					

MODEL	L	L1	L2	A	B	B1	B2	D	D1	D2	D3	D4	I	I1	I2	I3	M	H	H1	H2	WEIGHT kg
DMH 60/280.50 T	280	130	150	18	308	73	235	165	125	110	90	50	240	120	120	120	M14	556	278	278	44,5



DPH 60/280.50 M - WET ROTOR CIRCULATORS

Pumped liquid temperature range: from -10 °C to +120 °C - Maximum operating pressure: 10 bar (1000 kPa)

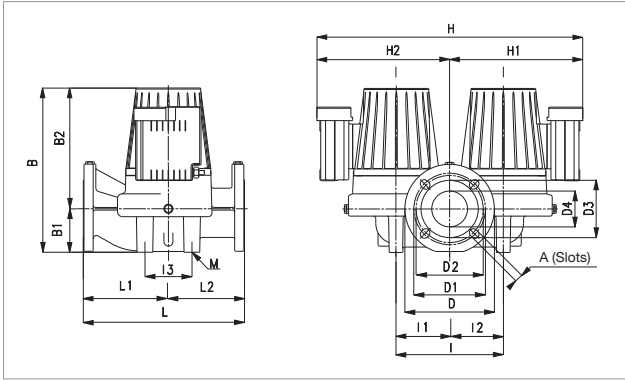

The performance curves are based on kinematic viscosity values = 1 mm²/s and density equal to 1000 kg/m³. Curve tolerance according to ISO 9906.

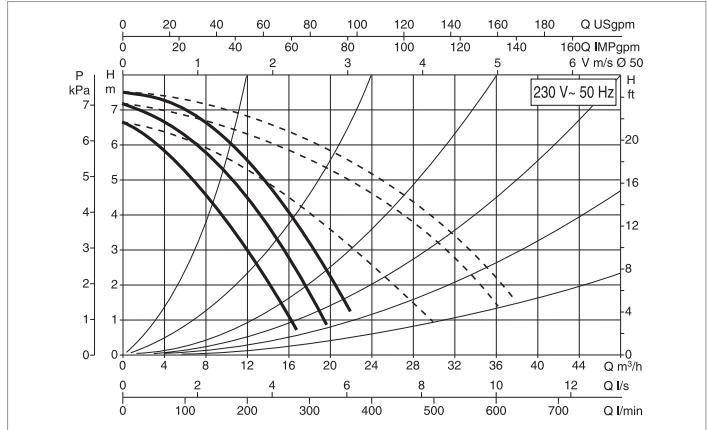

MODEL	CENTRE DISTANCE mm	COUNTERFLANGES ON REQUEST	ELECTRICAL DATA				MINIMUM SUCTION PRESSURE					
			POWER INPUT 50 Hz	SPEED	REV. 1/min	P1 MAX W	In A	t°	75°	90°	110°	120°
DPH 60/280.50 M	280	DN 50 - PN 10	1x230 V ~	3	2840	595	2.79	m.c.w.	1.6	6	14	-
				2	2730	540	2.45					
				1	2200	506	2.58					

MODEL	L	L1	L2	A	B	B1	B2	D	D1	D2	D3	D4	I	I1	I2	I3	M	H	H1	H2	WEIGHT kg
DPH 60/280.50 M	280	130	150	18	308	73	235	165	125	110	90	50	240	120	120	120	M14	554	278	278	44,5

DPH 60/280.50 T - WET ROTOR CIRCULATORS

Pumped liquid temperature range: from -10 °C to +120 °C - Maximum operating pressure: 10 bar (1000 kPa)

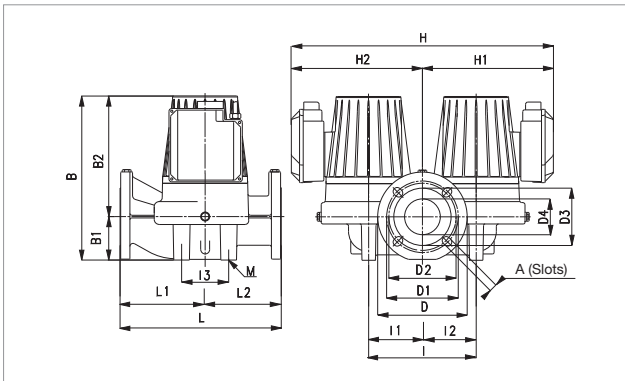

The performance curves are based on kinematic viscosity values = 1 mm²/s and density equal to 1000 kg/m³. Curve tolerance according to ISO 9906.

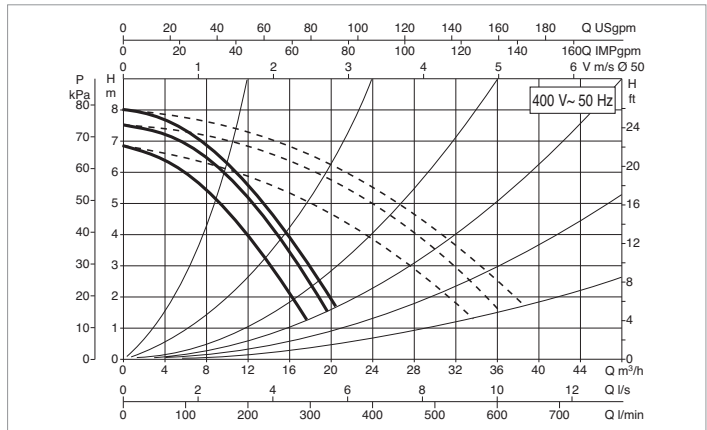

MODEL	CENTRE DISTANCE mm	COUNTERFLANGES ON REQUEST	ELECTRICAL DATA				MINIMUM SUCTION PRESSURE					
			POWER INPUT 50 Hz	SPEED	REV. 1/min	P1 MAX W	In A	t°	75°	90°	110°	120°
DPH 60/280.50 T	280	DN 50 - PN 10	3x230 V ~	2	2670	464	1.35	m.c.w.	1.6	6	-	19
				1	2570	432	1.23					
				3	2890	589	1.31					
			3x400 V ~	2	2860	546	1.1					
				1	2570	423	0.71					

MODEL	L	L1	L2	A	B	B1	B2	D	D1	D2	D3	D4	I	I1	I2	I3	M	H	H1	H2	WEIGHT kg
DPH 60/280.50 T	280	130	150	18	308	73	235	165	125	110	90	50	240	120	120	120	M14	554	278	278	44,5

DPH 120/280.50 M - WET ROTOR CIRCULATORS

Pumped liquid temperature range: from -10 °C to +90 °C - Maximum operating pressure: 10 bar (1000 kPa)

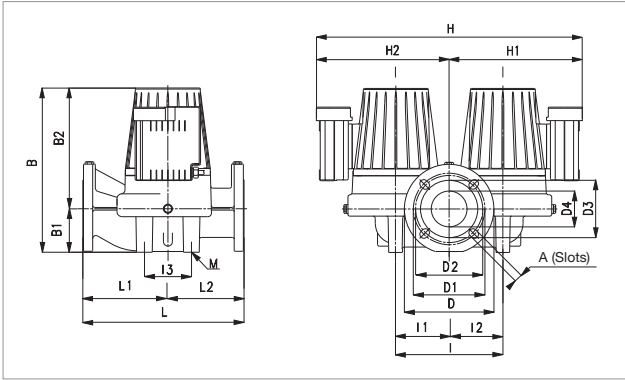

The performance curves are based on kinematic viscosity values = 1 mm²/s and density equal to 1000 kg/m³. Curve tolerance according to ISO 9906.

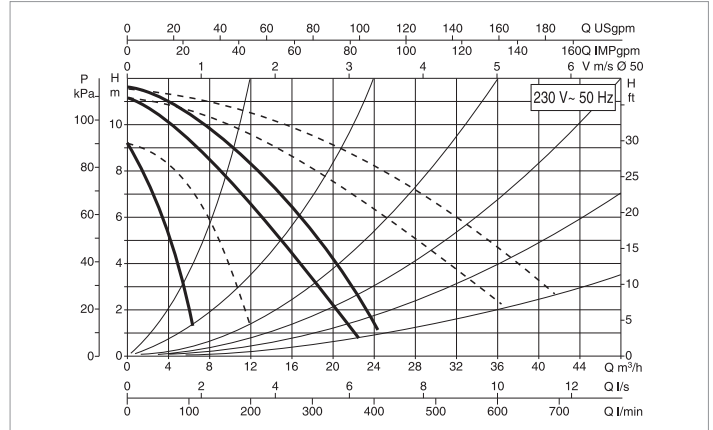

MODEL	CENTRE DISTANCE mm	COUNTERFLANGES ON REQUEST	ELECTRICAL DATA					MINIMUM SUCTION PRESSURE				
			POWER INPUT 50 Hz	SPEED	REV. 1/min	P1 MAX W	In A	t°	75°	90°	110°	120°
DPH 120/280.50 M	280	DN 50 - PN 10	1x230 V ~	3 2 1	2690 2360 1340	870 800 590	3,97 3,69 3,12	m.c.w.	2	5	-	20

MODEL	L	L1	L2	A	B	B1	B2	D	D1	D2	D3	D4	I	I1	I2	I3	M	H	H1	H2	WEIGHT kg
DPH 120/280.50 M	280	130	150	18	308	73	235	165	125	110	90	50	240	120	120	120	M14	556	278	278	44,5

DPH 120/280.50 T - WET ROTOR CIRCULATORS

Pumped liquid temperature range: from -10 °C to +120 °C - Maximum operating pressure: 10 bar (1000 kPa)

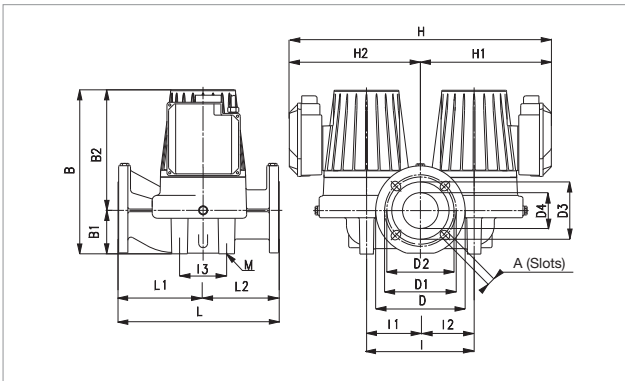

The performance curves are based on kinematic viscosity values = 1 mm²/s and density equal to 1000 kg/m³. Curve tolerance according to ISO 9906.

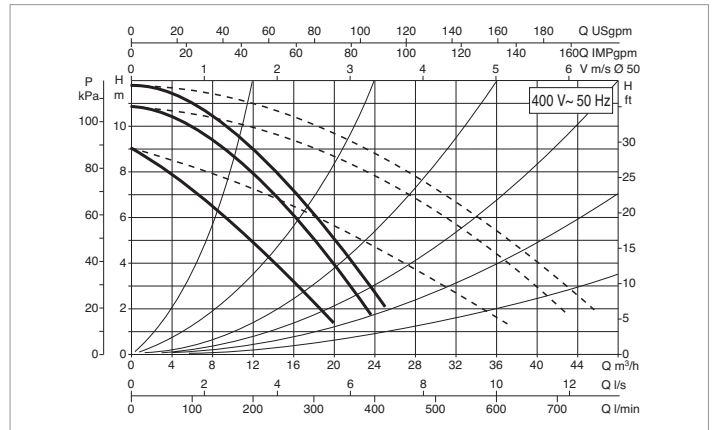

MODEL	CENTRE DISTANCE mm	COUNTERFLANGES ON REQUEST	ELECTRICAL DATA					MINIMUM SUCTION PRESSURE				
			POWER INPUT 50 Hz	SPEED	REV. 1/min	P1 MAX W	In A	t°	75°	90°	110°	120°
DPH 120/280.50 T	280	DN 50 - PN 10	3x230 V ~	2 1	2430 2240	683 605	1,95 1,75	m.c.w.	2	5	-	20
			3x400 V ~	3	2810	898	1,67					
				2 1	2740 2260	840 603	1,47 1					

MODEL	L	L1	L2	A	B	B1	B2	D	D1	D2	D3	D4	I	I1	I2	I3	M	H	H1	H2	WEIGHT kg
DPH 120/280.50 T	280	130	150	18	308	73	235	165	125	110	90	50	240	120	120	120	M14	556	278	278	49

DPH 150/280.50 T - WET ROTOR CIRCULATORS

Pumped liquid temperature range: from -10 °C to +110 °C - Maximum operating pressure: 10 bar (1000 kPa)

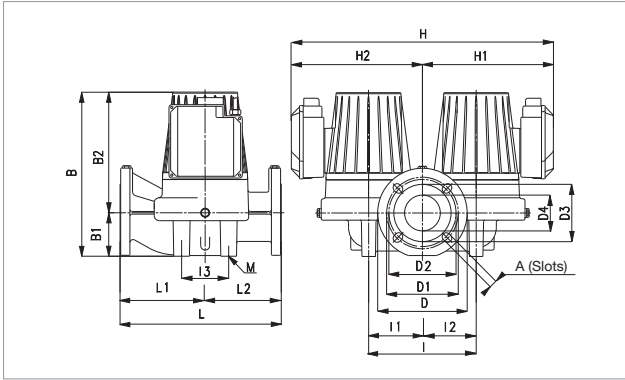

The performance curves are based on kinematic viscosity values = 1 mm²/s and density equal to 1000 kg/m³. Curve tolerance according to ISO 9906.

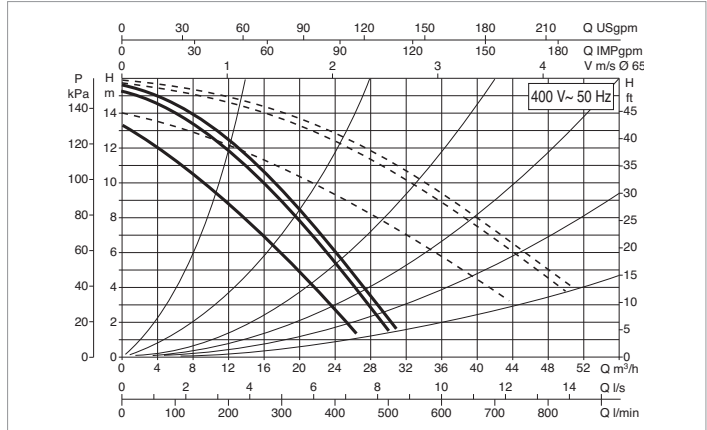

MODEL	CENTRE DISTANCE mm	COUNTERFLANGES ON REQUEST	ELECTRICAL DATA					MINIMUM SUCTION PRESSURE				
			POWER INPUT 50 Hz	SPEED	REV. 1/min	P1 MAX W	In A	t°	75°	90°	110°	120°
DPH 150/280.50 T	280	DN 50 - PN 10	3x230 V ~	2	2563	1130	3,22	m.c.w.	2	5	-	20
			3x400 V ~	2	2850	1470	2,9					
				1	2420	1032	3					
				3	2802	1360	2,5					
				1	2425	1030	1,7					

MODEL	L	L1	L2	A	B	B1	B2	D	D1	D2	D3	D4	I	I1	I2	I3	M	H	H1	H2	WEIGHT kg
DPH 150/280.50 T	280	130	150	18	358	73	285	165	125	110	90	50	240	120	120	120	M14	556	278	278	49

DPH 180/280.50 T - WET ROTOR CIRCULATORS

Pumped liquid temperature range: from -10 °C to +110 °C - Maximum operating pressure: 10 bar (1000 kPa)

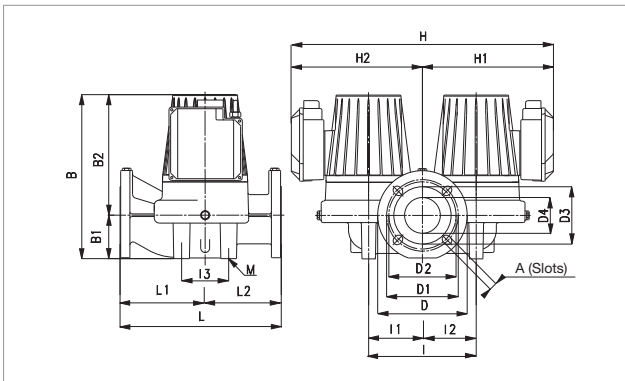

The performance curves are based on kinematic viscosity values = 1 mm²/s and density equal to 1000 kg/m³. Curve tolerance according to ISO 9906.

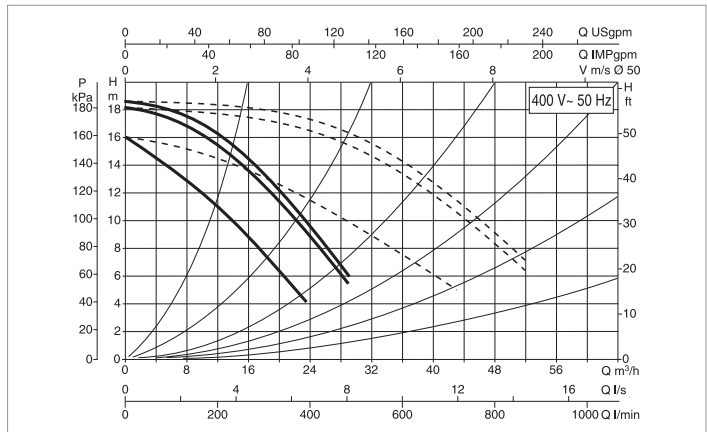

MODEL	CENTRE DISTANCE mm	COUNTERFLANGES ON REQUEST	ELECTRICAL DATA					MINIMUM SUCTION PRESSURE				
			POWER INPUT 50 Hz	SPEED	REV. 1/min	P1 MAX W	In A	t°	75°	90°	110°	120°
DPH 180/280.50 T	280	DN 50 - PN 10	3x230 V ~	2	2520	1230	3,5	m.c.w.	2	5	-	20
			3x400 V ~	2	2830	1630	3					
				1	2340	1120	3,2					
				3	2780	1540	2,70					
				1	2360	1130	1,85					

MODEL	L	L1	L2	A	B	B1	B2	D	D1	D2	D3	D4	I	I1	I2	I3	M	H	H1	H2	WEIGHT kg
DPH 180/280.50 T	280	130	150	18	358	73	285	165	125	110	90	50	240	120	120	120	M14	556	278	278	49

DMH 30/340.65 T- WET ROTOR CIRCULATORS

Pumped liquid temperature range: from -10 °C to +120 °C - Maximum operating pressure: 10 bar (1000 kPa)

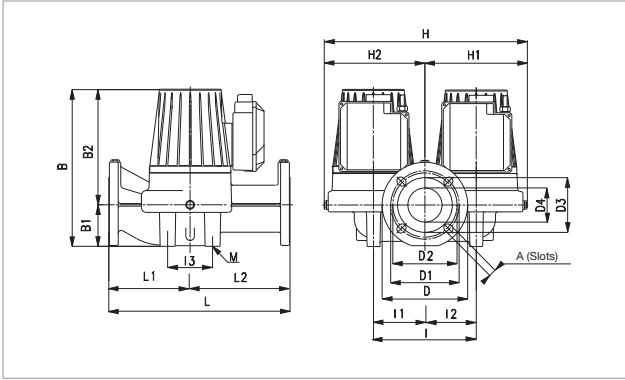

The performance curves are based on kinematic viscosity values = 1 mm²/s and density equal to 1000 kg/m³. Curve tolerance according to ISO 9906.

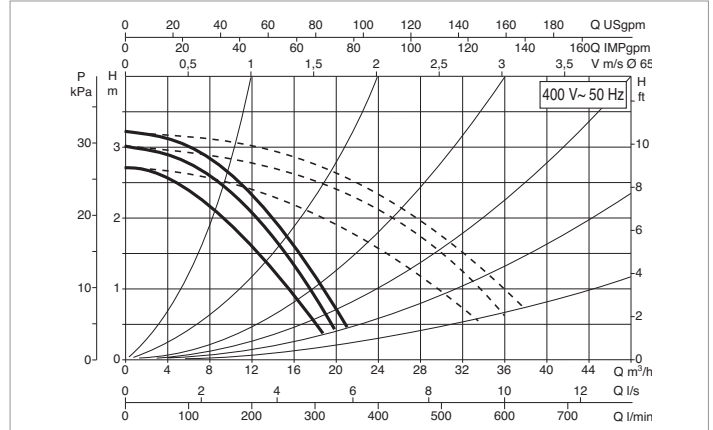

MODEL	CENTRE DISTANCE mm	COUNTERFLANGES ON REQUEST	ELECTRICAL DATA					MINIMUM SUCTION PRESSURE				
			POWER INPUT 50 Hz	SPEED	REV. 1/min	P1 MAX W	In A	t°	75°	90°	110°	120°
								m.c.w.	4	7.5	-	21
DMH 30/340.65 T	340	DN 65 - PN 10	3x230 V ~	2	1360	170	0.73	m.c.w.	4	7.5	-	21
			1	1310	154	0.60						
			3x400 V ~	3	1450	270	1.12					
				2	1430	233	0.84					
				1	1310	150	0.35					

MODEL	L	L1	L2	A	B	B1	B2	D	D1	D2	D3	D4	I	I1	I2	I3	M	H	H1	H2	WEIGHT kg
DMH 30/340.65 T	340	138,5	201,5	18	328	82	246	185	145	130	110	65	240	120	120	120	M14	476	238	238	57

DMH 60/340.65 T - WET ROTOR CIRCULATORS

Pumped liquid temperature range: from -10 °C to +120 °C - Maximum operating pressure: 10 bar (1000 kPa)

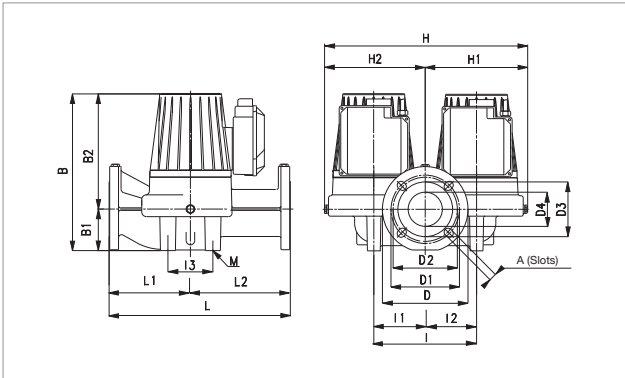

The performance curves are based on kinematic viscosity values = 1 mm²/s and density equal to 1000 kg/m³. Curve tolerance according to ISO 9906.

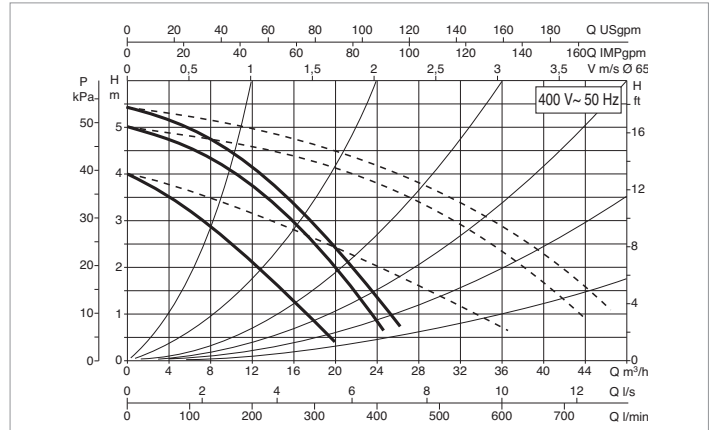

MODEL	CENTRE DISTANCE mm	COUNTERFLANGES ON REQUEST	ELECTRICAL DATA					MINIMUM SUCTION PRESSURE				
			POWER INPUT 50 Hz	SPEED	REV. 1/min	P1 MAX W	In A	t°	75°	90°	110°	120°
								m.c.w.	4	7.5	-	21
DMH 60/340.65 T	340	DN 65 - PN 10	3x230 V ~	2	1170	295	1	m.c.w.	4	7.5	-	21
			1	1070	257	0.85						
			3x400 V ~	3	1380	445	1.2					
				2	1350	403	0.97					
				1	1090	255	0.49					

MODEL	L	L1	L2	A	B	B1	B2	D	D1	D2	D3	D4	I	I1	I2	I3	M	H	H1	H2	WEIGHT kg
DMH 60/340.65 T	340	138,5	201,5	18	331	82	249	185	145	130	110	65	240	120	120	120	M14	476	238	238	50

DPH 60/340.65 M - WET ROTOR CIRCULATORS

Pumped liquid temperature range: from -10 °C to +110 °C - Maximum operating pressure: 10 bar (1000 kPa)

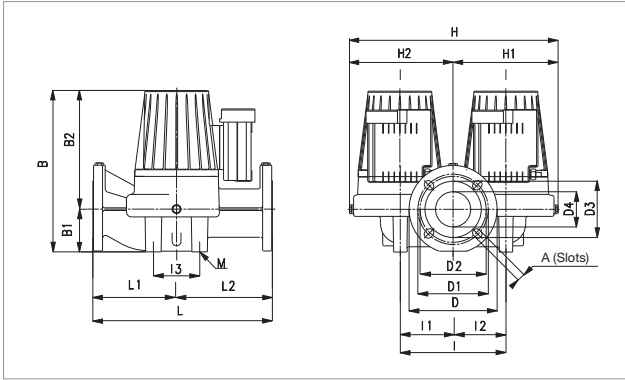

The performance curves are based on kinematic viscosity values = 1 mm²/s and density equal to 1000 kg/m³. Curve tolerance according to ISO 9906.

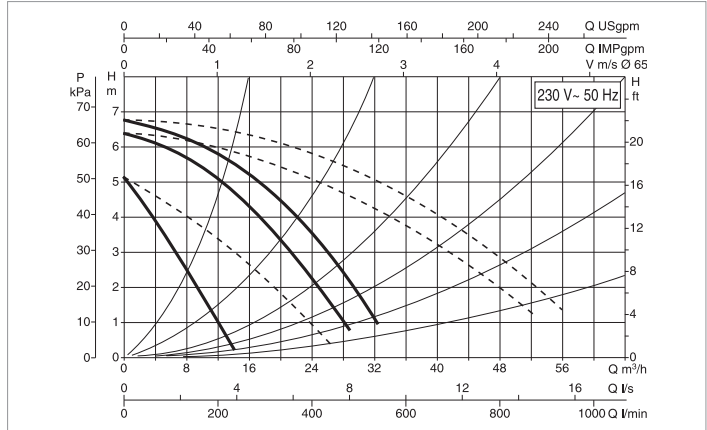

MODEL	CENTRE DISTANCE mm	COUNTERFLANGES ON REQUEST	ELECTRICAL DATA				MINIMUM SUCTION PRESSURE					
			POWER INPUT 50 Hz	SPEED	REV. 1/min	P1 MAX W	In A	t°	75°	90°	110°	120°
DPH 60/340.65 M	340	DN 65 - PN 10	1x230 V ~	3	2780	735	3.37	m.c.w.	1	4	13	-
				2	2580	685	3.13					
				1	1460	564	3.12					

MODEL	L	L1	L2	A	B	B1	B2	D	D1	D2	D3	D4	I	I1	I2	I3	M	H	H1	H2	WEIGHT kg
DPH 60/340.65 M	340	138,5	201,5	18	331	82	249	185	145	130	110	65	240	120	120	140	M14	476	238	238	50

DPH 60/340.65 T - WET ROTOR CIRCULATORS

Pumped liquid temperature range: from -10 °C to +120 °C - Maximum operating pressure: 10 bar (1000 kPa)

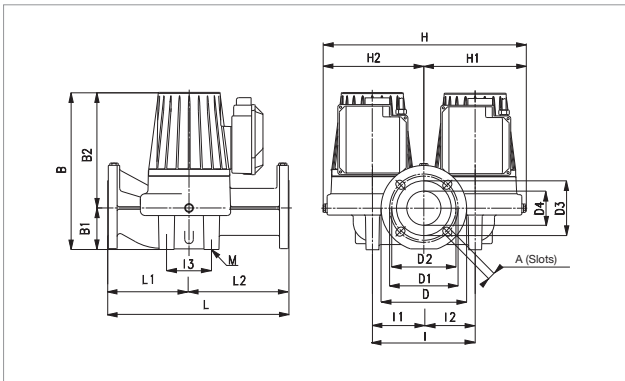

The performance curves are based on kinematic viscosity values = 1 mm²/s and density equal to 1000 kg/m³. Curve tolerance according to ISO 9906.

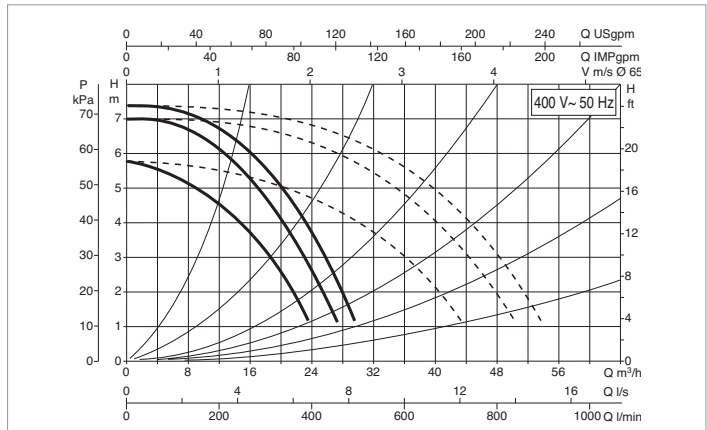

MODEL	CENTRE DISTANCE mm	COUNTERFLANGES ON REQUEST	ELECTRICAL DATA				MINIMUM SUCTION PRESSURE					
			POWER INPUT 50 Hz	SPEED	REV. 1/min	P1 MAX W	In A	t°	75°	90°	110°	120°
DPH 60/340.65 T	340	DN 65 - PN 10	3x230 V ~	2	2550	582	1.67	m.c.w.	1	4	-	18
				1	2380	532	1.53					
			3x400 V ~	3	2850	756	1.5					
				2	2800	705	1.3					
				1	2400	535	0.9					

MODEL	L	L1	L2	A	B	B1	B2	D	D1	D2	D3	D4	I	I1	I2	I3	M	H	H1	H2	WEIGHT kg
DPH 60/340.65 T	340	138,5	201,5	18	331	82	249	185	145	130	110	65	240	120	120	140	M14	476	238	238	54,5

DPH 120/340.65 T - WET ROTOR CIRCULATORS

Pumped liquid temperature range: from -10 °C to +110 °C - Maximum operating pressure: 10 bar (1000 kPa)

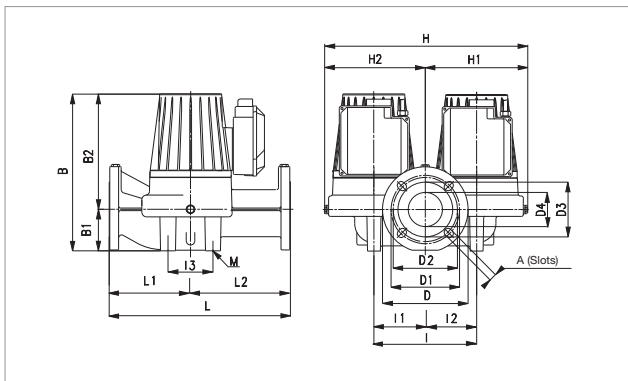

The performance curves are based on kinematic viscosity values = 1 mm²/s and density equal to 1000 kg/m³. Curve tolerance according to ISO 9906.

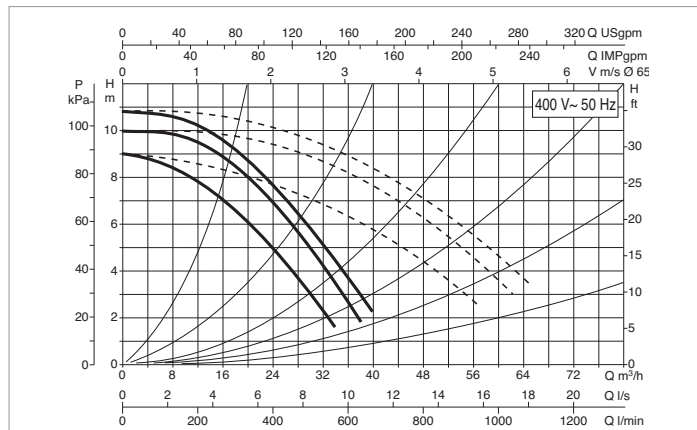

MODEL	CENTRE DISTANCE mm	COUNTERFLANGES ON REQUEST	ELECTRICAL DATA					MINIMUM SUCTION PRESSURE				
			POWER INPUT 50 Hz	SPEED	REV. 1/min	P1 MAX W	In A	t°	75°	90°	110°	120°
								m.c.w.	6	9	-	22
DPH 120/340.65 T	340	DN 65 - PN 10	3x230 V ~	2	2630	1001	2.85	m.c.w.	6	9	-	22
			1	2500	940	2.66						
DPH 120/340.65 T	340	DN 65 - PN 10	3x400 V ~	3	2880	1275	2.64	m.c.w.	6	9	-	22
				2	2830	1200	2.25					
				1	2520	934	1.52					

MODEL	L	L1	L2	A	B	B1	B2	D	D1	D2	D3	D4	I	I1	I2	I3	M	H	H1	H2	WEIGHT kg
DPH 120/340.65 T	340	138,5	201,5	18	381	82	299	185	145	130	110	65	240	120	120	140	M14	476	238	238	59

DPH 150/340.65 T - WET ROTOR CIRCULATORS

Pumped liquid temperature range: from -10 °C to +110 °C - Maximum operating pressure: 10 bar (1000 kPa)

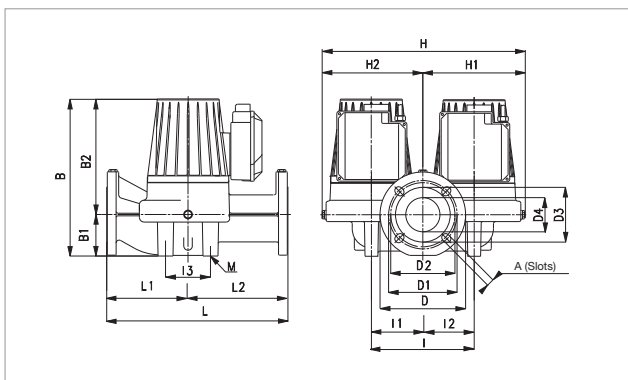

The performance curves are based on kinematic viscosity values = 1 mm²/s and density equal to 1000 kg/m³. Curve tolerance according to ISO 9906.

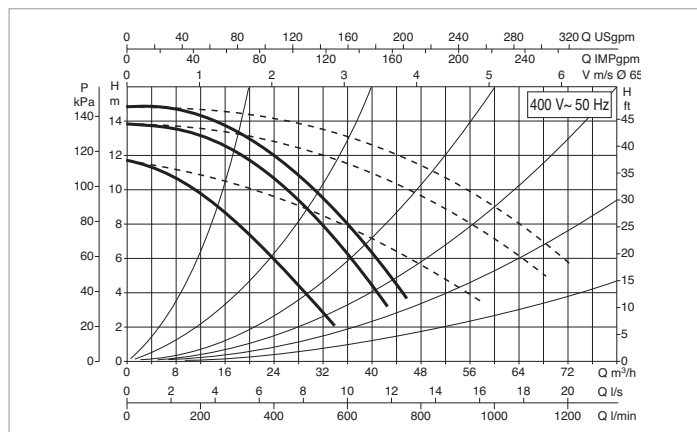

MODEL	CENTRE DISTANCE mm	COUNTERFLANGES ON REQUEST	ELECTRICAL DATA					MINIMUM SUCTION PRESSURE				
			POWER INPUT 50 Hz	SPEED	REV. 1/min	P1 MAX W	In A	t°	75°	90°	110°	120°
								m.c.w.	7	11	18	-
DPH 150/340.65 T	340	DN 65 - PN 10	3x230 V ~	2	2410	1345	3.8	m.c.w.	7	11	18	-
			1	2250	1188	3.36						
DPH 150/340.65 T	340	DN 65 - PN 10	3x400 V ~	3	2800	1796	3.25	m.c.w.	7	11	18	-
				2	2730	1690	2.93					
				1	2250	1210	2					

MODEL	L	L1	L2	A	B	B1	B2	D	D1	D2	D3	D4	I	I1	I2	I3	M	H	H1	H2	WEIGHT kg
DPH 150/340.65 T	340	138,5	201,5	18	381	82	299	185	145	130	110	65	240	120	120	140	M14	476	238	238	59

DPH 180/340.65 T - WET ROTOR CIRCULATORS

Pumped liquid temperature range: from -10 °C to +110 °C - Maximum operating pressure: 10 bar (1000 kPa)

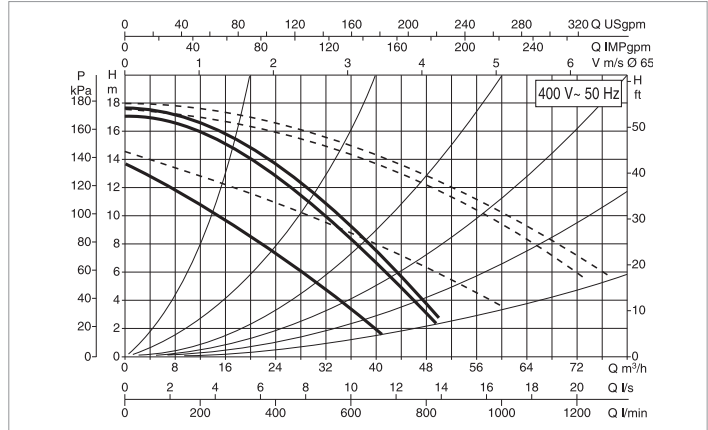
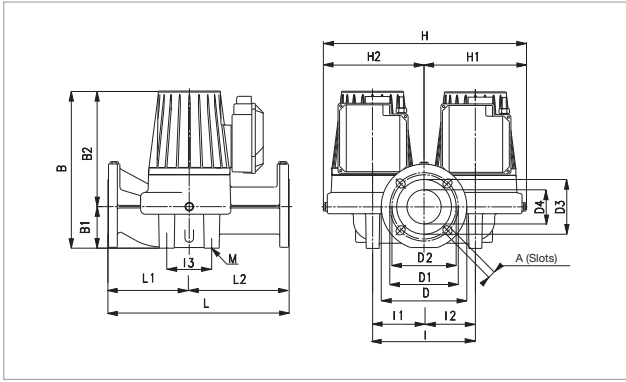

The performance curves are based on kinematic viscosity values = 1 mm²/s and density equal to 1000 kg/m³. Curve tolerance according to ISO 9906.

MODEL	CENTRE DISTANCE mm	COUNTERFLANGES ON REQUEST	ELECTRICAL DATA					MINIMUM SUCTION PRESSURE				
			POWER INPUT 50 Hz	SPEED	REV. 1/min	P1 MAX W	I _n A	t°	75°	90°	110°	120°
DPH 180/340.65 T	340	DN 65 - PN 10	3x230 V ~	2	2380	1670	4,7	m.c.w.	7	11	18	-
			3x400 V ~	1	2170	1490	4,25					
				3	2780	2310	4					
				2	2700	2210	3,5					
				1	2200	1490	2,4					

MODEL	L	L1	L2	A	B	B1	B2	D	D1	D2	D3	D4	I	I1	I2	I3	M	H	H1	H2	WEIGHT kg
DPH 180/340.65 T	340	138,5	201,5	18	381	82	299	185	145	130	110	65	240	120	120	140	M14	476	238	238	59

DMH 30/360.80 T - WET ROTOR CIRCULATORS

Pumped liquid temperature range: from -10 °C to +120 °C - Maximum operating pressure: 10 bar (1000 kPa)

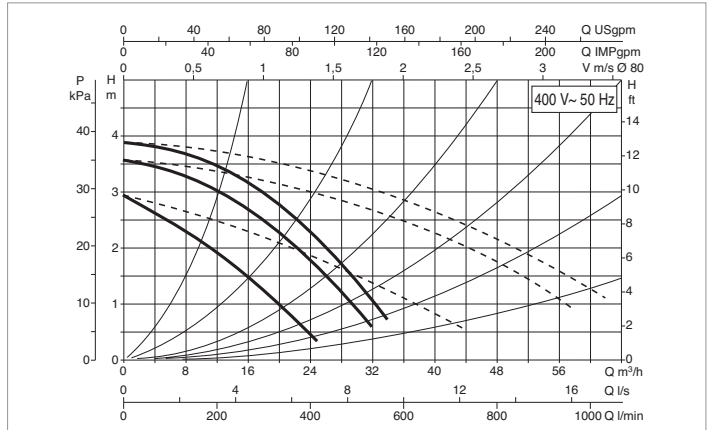
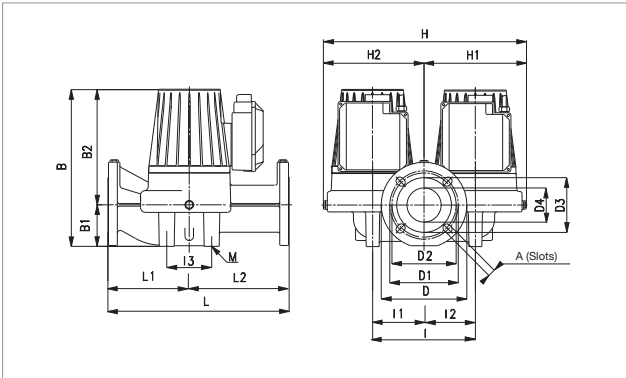

The performance curves are based on kinematic viscosity values = 1 mm²/s and density equal to 1000 kg/m³. Curve tolerance according to ISO 9906.

MODEL	CENTRE DISTANCE mm	COUNTERFLANGES ON REQUEST	ELECTRICAL DATA					MINIMUM SUCTION PRESSURE				
			POWER INPUT 50 Hz	SPEED	REV. 1/min	P1 MAX W	I _n A	t°	75°	90°	110°	120°
DMH 30/360.80 T	360	DN 80 - PN 10	3x230 V ~	2	1110	313	1.05	m.c.w.	4	7.5	-	21
			3x400 V ~	1	1010	268	0.88					
				3	1370	484	1.23					
				2	1330	437	1					
				1	1030	266	0.51					

MODEL	L	L1	L2	A	B	B1	B2	D	D1	D2	D3	D4	I	I1	I2	I3	M	H	H1	H2	WEIGHT kg
DMH 30/360.80 T	360	160	200	18	345	97	248	200	160	150	130	80	240	120	120	150	M14	480	240	240	54,5

DMH 60/360.80 T - WET ROTOR CIRCULATORS

Pumped liquid temperature range: from -10 °C to +120 °C - Maximum operating pressure: 10 bar (1000 kPa)

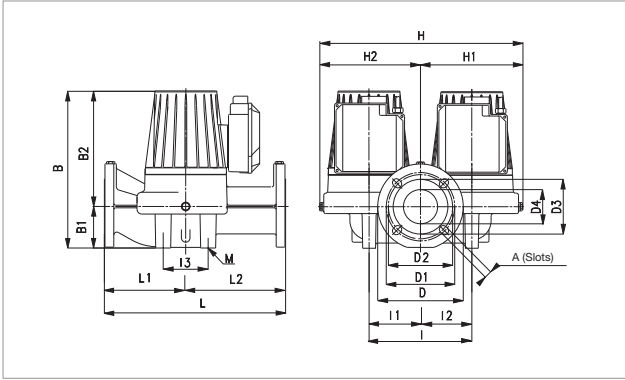

The performance curves are based on kinematic viscosity values = 1 mm²/s and density equal to 1000 kg/m³. Curve tolerance according to ISO 9906.

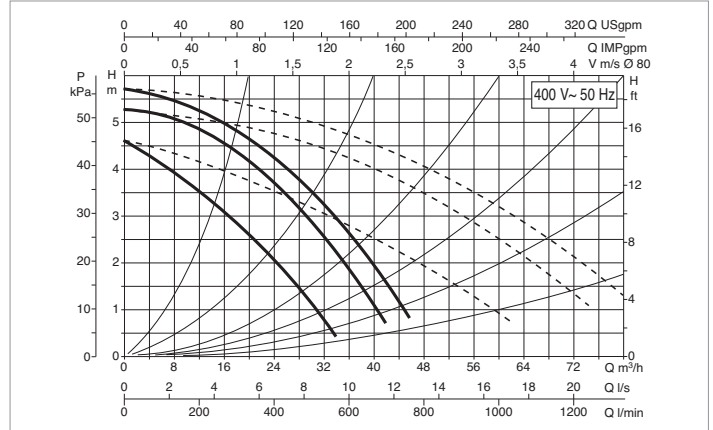

MODEL	CENTRE DISTANCE mm	COUNTERFLANGES ON REQUEST	ELECTRICAL DATA					MINIMUM SUCTION PRESSURE				
			POWER INPUT 50 Hz	SPEED	REV. 1/min	P1 MAX W	In A	t°	75°	90°	110°	120°
DMH 60/360.80 T	360	DN 80 - PN 10	3x230 V ~	2	1180	535	1.82	m.c.w.	2	5	-	20
			3x400 V ~	1	1100	465	1.55					
			3x400 V ~	2	1350	675	2.04					
				1	1100	465	0.89					

MODEL	L	L1	L2	A	B	B1	B2	D	D1	D2	D3	D4	I	I1	I2	I3	M	H	H1	H2	WEIGHT kg
DMH 60/360.80 T	360	160	200	18	390	97	298	200	160	150	130	80	240	120	120	150	M14	480	240	240	72

DPH 120/360.80 T - WET ROTOR CIRCULATORS

Pumped liquid temperature range: from -10 °C to +120 °C - Maximum operating pressure: 10 bar (1000 kPa)

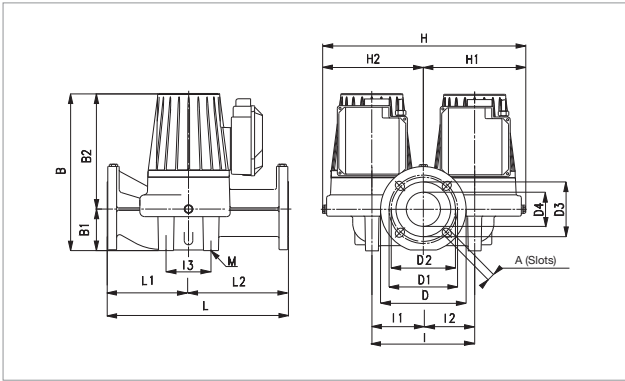

The performance curves are based on kinematic viscosity values = 1 mm²/s and density equal to 1000 kg/m³. Curve tolerance according to ISO 9906.

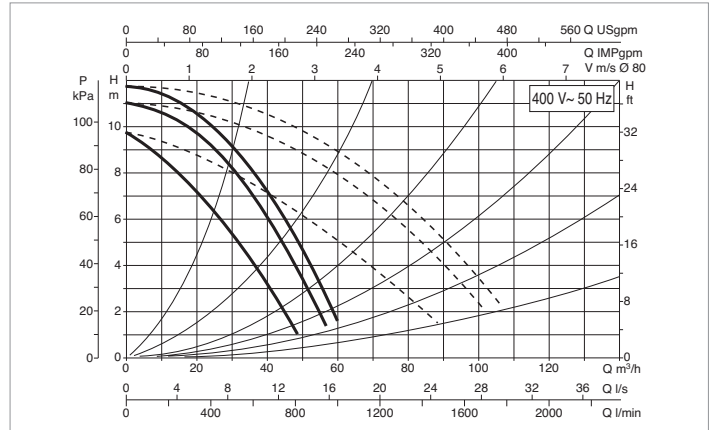

MODEL	CENTRE DISTANCE mm	COUNTERFLANGES ON REQUEST	ELECTRICAL DATA					MINIMUM SUCTION PRESSURE				
			POWER INPUT 50 Hz	SPEED	REV. 1/min	P1 MAX W	In A	t°	75°	90°	110°	120°
DPH 120/360.80 T	360	DN 80 - PN 10	3x230 V ~	2	2500	1410	3.95	m.c.w.	6	10	-	22
			3x400 V ~	1	2340	1292	3.6					
			3x400 V ~	2	2780	1710	2.93					
				1	2350	1302	2.13					

MODEL	L	L1	L2	A	B	B1	B2	D	D1	D2	D3	D4	I	I1	I2	I3	M	H	H1	H2	WEIGHT kg
DPH 120/360.80 T	360	160	200	18	390	97	298	200	160	150	130	80	240	120	120	150	M14	480	240	240	72

DPH 150/360.80 T - WET ROTOR CIRCULATORS

Pumped liquid temperature range: from -10 °C to +110 °C - Maximum operating pressure: 10 bar (1000 kPa)

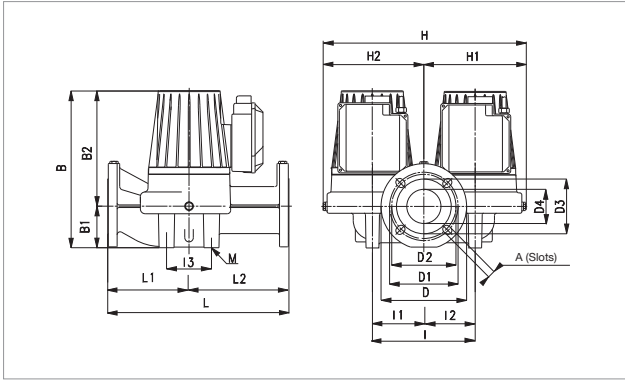

The performance curves are based on kinematic viscosity values = 1 mm²/s and density equal to 1000 kg/m³. Curve tolerance according to ISO 9906.

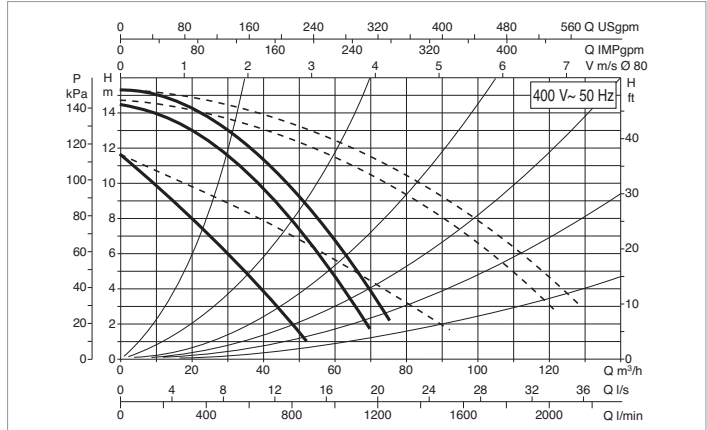

MODEL	CENTRE DISTANCE mm	COUNTERFLANGES ON REQUEST	ELECTRICAL DATA					MINIMUM SUCTION PRESSURE				
			POWER INPUT 50 Hz	SPEED	REV. 1/min	P1 MAX W	In A	t°	75°	90°	110°	120°
DPH 150/360.80 T	360	DN 80 - PN 10	3x230 V ~	2	2140	1984	5.62	m.c.w.	7	11	18	-
			1	1900	1695	4.82						
DPH 150/360.80 T	360	DN 80 - PN 10	3x400 V ~	3	2710	2870	4.64	m.c.w.	7	11	18	-
				2	2610	2686	4.32					
				1	1940	1710	2.85					

MODEL	L	L1	L2	A	B	B1	B2	D	D1	D2	D3	D4	I	I1	I2	I3	M	H	H1	H2	WEIGHT kg
DPH 150/360.80 T	360	160	200	18	390	97	298	200	160	150	130	80	240	120	120	150	M14	480	240	240	72

DPH 180/360.80 T - WET ROTOR CIRCULATORS

Pumped liquid temperature range: from -10 °C to +110 °C - Maximum operating pressure: 10 bar (1000 kPa)

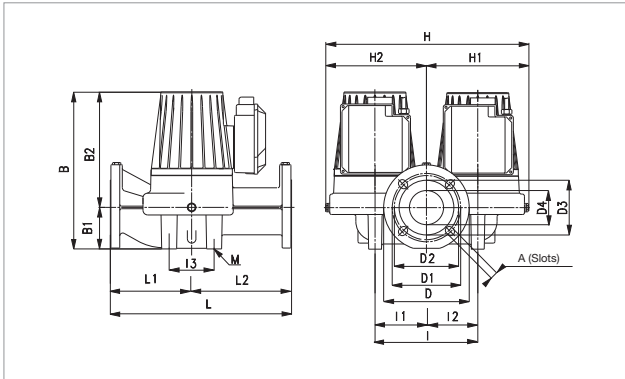

The performance curves are based on kinematic viscosity values = 1 mm²/s and density equal to 1000 kg/m³. Curve tolerance according to ISO 9906.

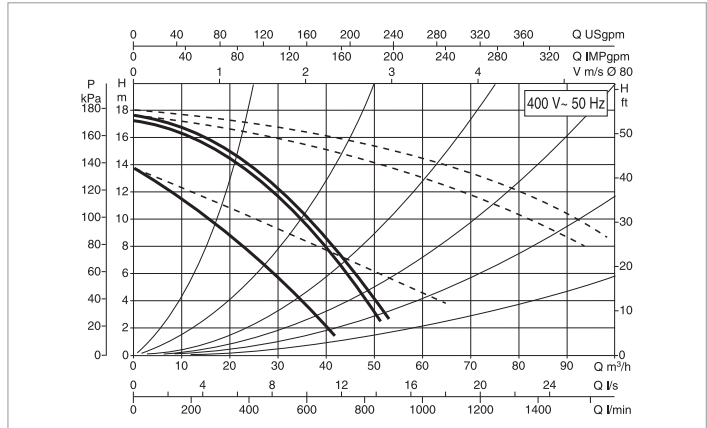

MODEL	CENTRE DISTANCE mm	COUNTERFLANGES ON REQUEST	ELECTRICAL DATA					MINIMUM SUCTION PRESSURE				
			POWER INPUT 50 Hz	SPEED	REV. 1/min	P1 MAX W	In A	t°	75°	90°	110°	120°
DPH 180/360.80 T	360	DN 80 - PN 10	3x230 V ~	2	2380	1670	4,7	m.c.w.	7	11	18	-
			1	2170	1490	4,25						
DPH 180/360.80 T	360	DN 80 - PN 10	3x400 V ~	3	2780	2310	4	m.c.w.	7	11	18	-
				2	2700	2210	3,5					
				1	2200	1490	2,4					

MODEL	L	L1	L2	A	B	B1	B2	D	D1	D2	D3	D4	I	I1	I2	I3	M	H	H1	H2	WEIGHT kg
DPH 180/360.80 T	360	160	200	18	390	97	298	200	160	150	130	80	240	120	120	150	M14	480	240	240	72



TECHNICAL DATA

Operating range: from 0,6 a 3,7 m³/h with head of up to 6 metres
Pumped liquid temperature range: from -10 °C to +85 °C for sanitary uses, and +110 °C for other uses

To avoid the formation of calcium, do not exceed 65 °C, and include a calcium removal system when the hardness of the water exceeds 15 French degrees

Pumped liquid: clean, free of solids and mineral oils, non-viscous, chemically neutral, with properties similar to water (glycol max 30%)

Maximum operating pressure: 10 bar (1000 kPa)

Minimum suction pressure: the values are shown in the corresponding tables

Installation: with HORIZONTAL MOTOR AXIS

Special executions on requests: alternative voltages and frequencies

Accessories: 1/2"F - 3/4"F - 1"F union connectors

copper piping welded union connectors: Ø 22 mm
 Ø 28 mm

APPLICATIONS

Pump for hot for water circulation in pressurised closed circuit, or open circulation type, domestic heating and air conditioning systems.

CONSTRUCTION FEATURES

Single body consisting of the cast iron hydraulic section and the wet rotor motor. Die-cast aluminium motor casing. Technopolymer impeller. Tempered stainless steel motor shaft on graphite bushings lubricated by the pumped liquid. Stainless steel rotor liner, stator liner and closing flange. Ceramic thrust ring, silicon seal rings, and brass air breather plug. The wet rotor asynchronous two-pole motor is protected as far as resistance, and does not require overload protection.

Three-speed operation.

Protection class: IP 44

Insulation class: F

Cable gland: PG 11

Installation: with horizontal motor axis.

Standard voltage: single-phase 230 V / 50 Hz

Special versions on request: - alternative voltages and/or frequencies

MATERIALS

N.	PARTS	MATERIALS
1	PUMP BODY	BRONZE
4	IMPELLER	TECHNOPOLYMER
7A	MOTOR SHAFT	CERAMIC
7B	ROTOR	-
8	STATOR	-
9	CAPACITOR	-
10	MOTOR CASING	DIE-CAST ALUMINIUM
11	BREATHER PLUG	BRASS
100	TERMINAL BOX	-
127	SEAL RING	ETHILENE PROPYLENE
128	STATOR LINER	STAINLESS STEEL
129	ROTOR LINER	STAINLESS STEEL
130	CLOSING FLANGE	STAINLESS STEEL
131	THRUST RING SUPPORT	ETHILENE PROPYLENE
132	BUSHINGS	GRAPHITE
133	THRUST RING	CERAMIC

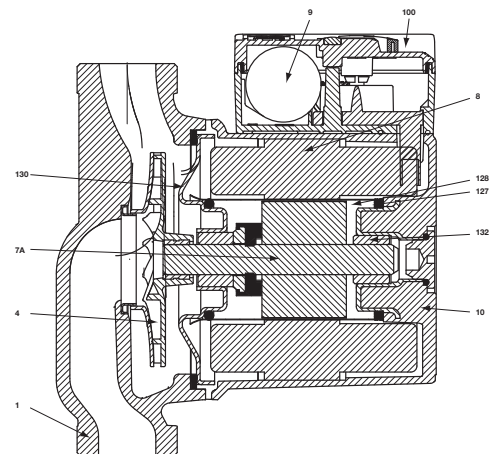

- Legend:
 (example)

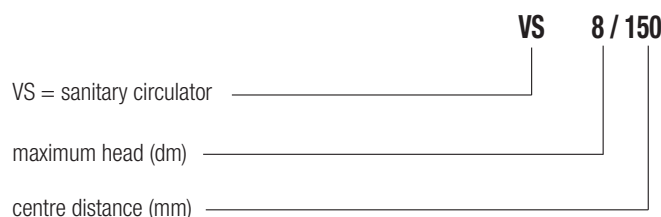

VS - WET ROTOR CIRCULATORS

Pumped liquid temperature range: from -10 °C to +110°C - Maximum operating pressure: 10 bar (1000 kPa)

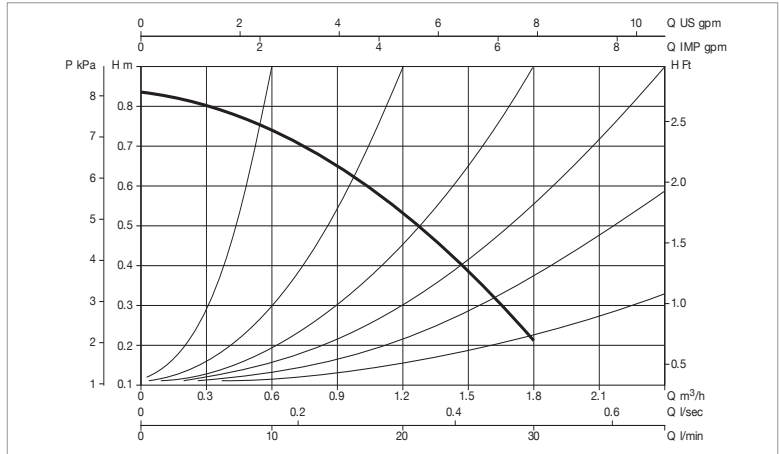
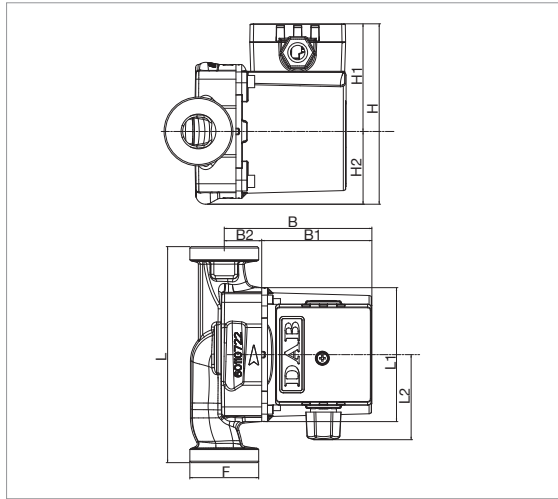

The performance curves are based on kinematic viscosity values = 1 mm²/s and density equal to 1000 kg/m³. Curve tolerance according to ISO 9906.

MODEL	Q=m ³ h	0	0,6	1,2	1,8	2,4	3	4,2	5,4
	Q=l/min	0	10	20	30	40	50	70	90
VS 8/150 M	H (m)	0,83	0,75	0,52	0,22	-	-	-	-

MODEL	POWER INPUT 50 Hz	CENTRE DISTANCE mm	PUMP CONNECTIONS	UNIONS ON REQUEST	P1 MAX W	In A	CAPACITOR		MINIMUM SUCTION PRESSURE	
							µF	Vc	t°	90°
VS 8/150 M	1 x 230 V ~	150	1 1/2"	Brass 1/2" F - 3/4" F - 1" F Copper d22 e d28	35	0,19	1,5	450	m.c.w.	1,5

MODEL	L	L1	L2	B	B1	B2	H	H1	H2	F GAS	PACKING DIMENSIONS			VOLUME m ³	WEIGHT Kg
											L	B	H		
VS 8/150 M	150	98	60	104	78	26	124	75	49	1 1/2"	134	188	150	0,0038	2,6

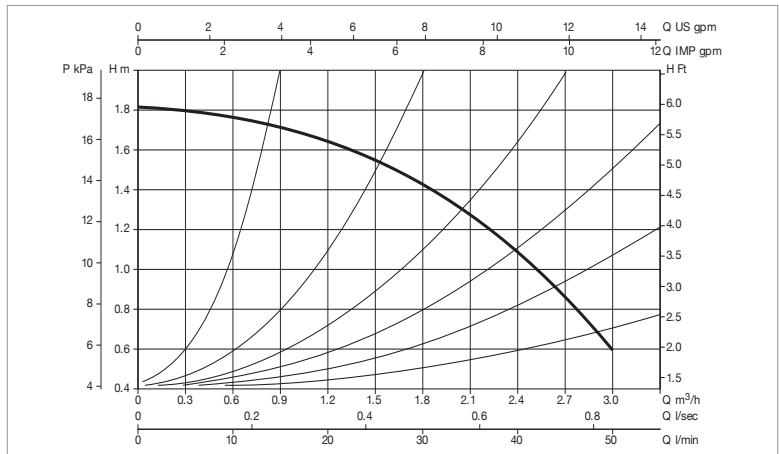
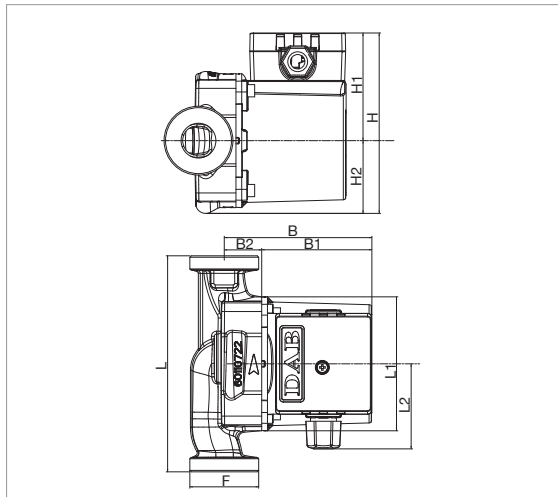

The performance curves are based on kinematic viscosity values = 1 mm²/s and density equal to 1000 kg/m³. Curve tolerance according to ISO 9906.

MODEL	Q=m ³ h	0	0,6	1,2	1,8	2,4	3	4,2	5,4
	Q=l/min	0	10	20	30	40	50	70	90
VS 16/150 M	H (m)	1,82	1,75	1,65	1,44	1,07	0,6	-	-

MODEL	POWER INPUT 50 Hz	CENTRE DISTANCE mm	PUMP CONNECTIONS	UNIONS ON REQUEST	P1 MAX W	In A	CAPACITOR		MINIMUM SUCTION PRESSURE	
							µF	Vc	t°	90°
VS 16/150 M	1 x 230 V ~	150	1 1/2"	Brass 1/2" F - 3/4" F - 1" F Copper d22 e d28	41	0,19	1,5	450	m.c.w.	1,5

MODEL	L	L1	L2	B	B1	B2	H	H1	H2	F GAS	PACKING DIMENSIONS			VOLUME m ³	WEIGHT Kg
											L	B	H		
VS 16/150 M	150	98	60	104	78	26	124	75	49	1 1/2"	134	188	150	0,0038	2,6



VS - WET ROTOR CIRCULATORS

Pumped liquid temperature range: from -10 °C to +110 °C - Maximum operating pressure: 10 bar (1000 kPa)

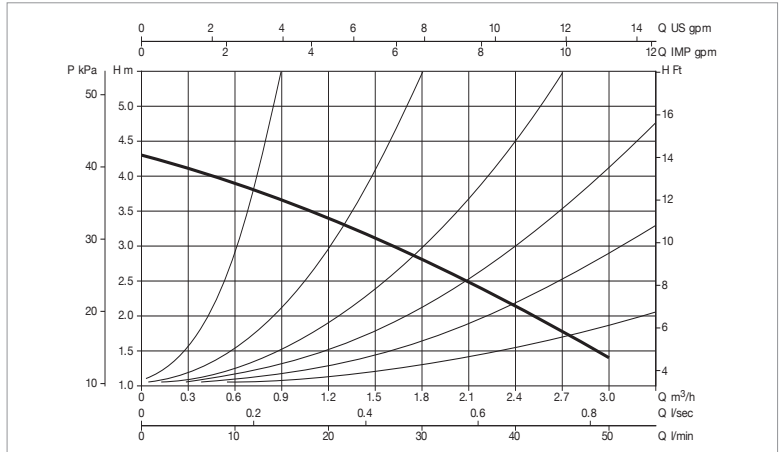
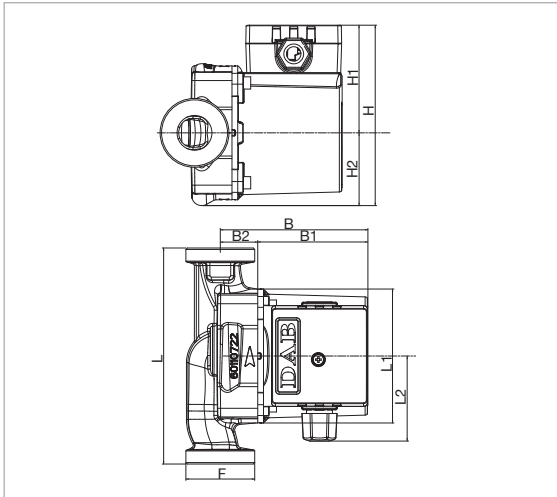

The performance curves are based on kinematic viscosity values = 1 mm²/s and density equal to 1000 kg/m³. Curve tolerance according to ISO 9906.

MODEL	Q=m ³ /h	0	0,6	1,2	1,8	2,4	3	4,2	5,4
	Q=l/min	0	10	20	30	40	50	70	90
VS 35/150 M	H (m)	4,1	3,7	3,3	2,82	2,2	1,3	-	-

MODEL	POWER INPUT 50 Hz	CENTRE DISTANCE mm	PUMP CONNECTIONS	UNIONS ON REQUEST	P1 MAX W	In A	CAPACITOR		MINIMUM SUCTION PRESSURE	
							µF	Vc	t°	90°
VS 35/150 M	1 x 230 V ~	150	1 1/2"	Brass 1/2" F - 3/4" F - 1" F Copper d22 e d28	55	0,24	1,7	450	m.c.w.	1,5

MODEL	L	L1	L2	B	B1	B2	H	H1	H2	F GAS	PACKING DIMENSIONS			VOLUME m ³	WEIGHT Kg
											L	B	H		
VS 35/150 M	150	98	60	104	78	26	124	75	49	1 1/2"	134	188	150	0,0038	2,6

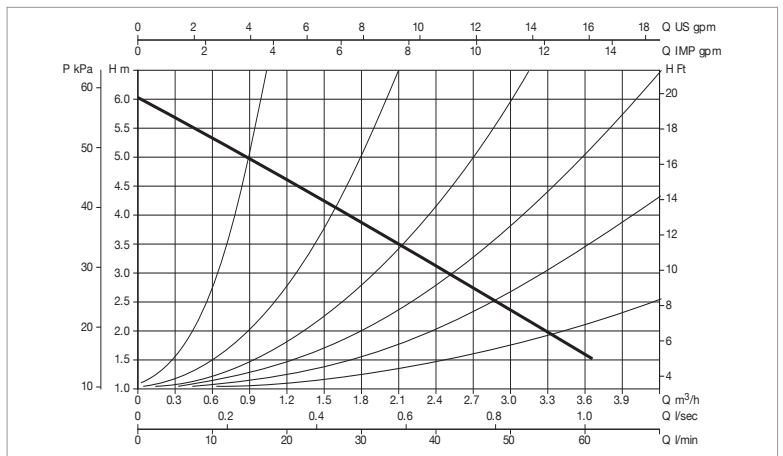
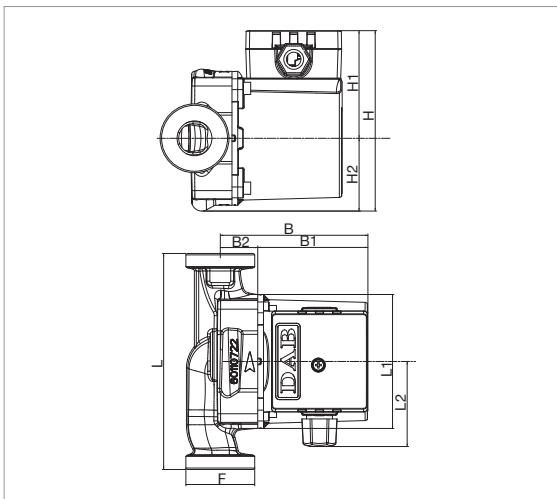

The performance curves are based on kinematic viscosity values = 1 mm²/s and density equal to 1000 kg/m³. Curve tolerance according to ISO 9906.

MODEL	Q=m ³ /h	0	0,6	1,2	1,8	2,4	3	4,2	5,4
	Q=l/min	0	10	20	30	40	50	70	90
VS 65/150 M	H (m)	6	5,3	4,6	3,85	3,1	2,35	-	-

MODEL	POWER INPUT 50 Hz	CENTRE DISTANCE mm	PUMP CONNECTIONS	UNIONS ON REQUEST	P1 MAX W	In A	CAPACITOR		MINIMUM SUCTION PRESSURE	
							µF	Vc	t°	90°
VS 65/150 M	1 x 230 V ~	150	1 1/2"	Brass 1/2" F - 3/4" F - 1" F Copper d22 e d28	78	0,34	2	450	m.c.w.	1,5

MODEL	L	L1	L2	B	B1	B2	H	H1	H2	F GAS	PACKING DIMENSIONS			VOLUME m ³	WEIGHT Kg
											L	B	H		
VS 65/150 M	150	98	60	104	78	26	124	75	49	1 1/2"	134	188	150	0,0038	2,6



ACCESSORIES

D.MAG COMPACT

MAGNETIC FILTER



Ideal to protect heating systems and the circulator from iron sludge and other impurities. It lengthens the life of the boiler and the pump, improving the efficiency of the entire system.

- High filtration performances
- Easy to install and service
- Extremely compact (< 200 mm)
- Improves the efficiency of the system

Operating range

Flow rate up to 3 m³/h

Liquid temperature range

up to + 90°C

Fittings 1"

Max operating pressure 6 bar

Filter height 133 mm



MODEL
D.MAG COMPACT

RECOMMENDED FOR:	
 EVOSTA 2	 EVOSTA 3

D.MAG PRO TWIN

MAGNETIC FILTER



Ideal to protect heating systems and the circulator from iron sludge and other impurities. It lengthens the life of the boiler and the pump, improving the efficiency of the entire system.

- High filtration performances
- Easy to install and service
- Minimal pressure losses
- Improves the efficiency of the system

Operating range

Flow rate up to 6 m³/h

Liquid temperature range

up to + 95°C

Fittings 1" 1/4 - 1" 1/2

Max operating pressure 6 bar



MODEL
D.MAG PRO TWIN

RECOMMENDED FOR:
 evoplus⁺ SMALL

COMMERCIAL MAGNETIC FILTERS

2" MAGNACLEAN (DN 50 CP1 – 03 -01123)



3" MAGNACLEAN (DN 80 CP1 – 03 -01124)

4" MAGNACLEAN (DN 100 CP1 – 03 -01125)

RECOMMENDED FOR:
EVOPLUS AND IN-LINE PUMPS

ACCESSORIES

CIRCULATORS

UNION KIT	DESCRIPTION	MODEL	WEIGHT Kg	Q.TY X BOX
 <p>1" F UNION KIT</p>	½" F UNION KIT	EVOSTA 2 40-70/130-1/2	0,4	24
		EVOSTA 3 40/130 1/2 - 60/130 1/2 - 80/130 1/2		
		EVOSTA 3 40/130 1/2 SOL - 60/130 1/2 SOL - 80/130 1/2 SOL		
		VSA 35/130-½" - 55/130-½" - 65/130-½"		
	¾" F UNION KIT	EVOSTA 2 40-70/130 - EVOSTA 2 40-70/180	0,4	24
		EVOSTA 3 40/130 - 60/130 - 80/130 EVOSTA 3 40/180 - 60/180 - 80/180		
		EVOSTA 3 40/180 SOL - 60/180 SOL - 80/180 SOL		
		EVOPLUS 40/180 - 60/180 - 80/180 - 110/180		
		VSA 35/130 - 55/130 - 65/130 VSA 35/180 - 55/180 - 65/180		
	1" F UNION KIT	EVOSTA 2 40-70/130 - EVOSTA 2 40-70/180	0,4	24
		EVOSTA 3 40/130 - 60/130 - 80/130 EVOSTA 3 40/180 - 60/180 - 80/180		
		EVOSTA 3 40/180 SOL - 60/180 SOL - 80/180 SOL		
EVOPLUS 40/180 - 60/180 - 80/180 - 110/180				
VSA 35/130 - 55/130 - 65/130 VSA 35/180 - 55/180 - 65/180				
1" ¼ F UNION KIT	EVOSTA 3 40/180 X - 60/180 X - 80/180 X	0,7	24	
	EVOPLUS 40/180 X - 60/180 X - 80/180 X - 110/180 X			
	EVOPLUS 40/180 X - 60/180 X - 80/180 X - 110/180 X			
 <p>1" ¼ M UNION KIT</p>	1" ¼ M UNION KIT	EVOSTA 2 40-70/130 EVOSTA 2 40-70/180	0,4	24
		EVOSTA 3 40/130 - 60/130 - 80/130 EVOSTA 3 40/180 - 60/180 - 80/180		
		EVOPLUS 40/180 - 60/180 - 80/180 - 110/180		

PIPE UNIONS	DESCRIPTION	MODEL	WEIGHT Kg	Q.TY X BOX
 <p>1" F BRASS UNION KIT</p>	½" F BRASS UNION KIT	EVOSTA 3 SAN EVOPLUS SMALL SAN	0,4	24
		VS 8/150 - 16/150 - 35/150 - 65/150		
	¾" F BRASS UNION KIT	EVOSTA 3 SAN EVOPLUS SMALL SAN	0,4	24
		VS 8/150 - 16/150 - 35/150 - 65/150		
	1" F BRASS UNION KIT	EVOSTA 3 SAN EVOPLUS SMALL SAN	0,4	24
		VS 8/150 - 16/150 - 35/150 - 65/150		



ACCESSORIES

CIRCULATORS

COPPER KIT UNIONS	DESCRIPTION	MODEL	WEIGHT Kg
 <p>COPPER UNION KIT TO SOLDER Ø 22</p>	COPPER UNION KIT TO SOLDER Ø 22	EVOSTA 3 SAN EVOPLUS SMALL SAN	0,4
		VS 8/150 - 16/150 - 35/150 - 65/150	
	COPPER UNION KIT TO SOLDER Ø 28	EVOSTA 3 SAN EVOPLUS SMALL SAN	0,4
		VS 8/150 - 16/150 - 35/150 - 65/150	

REDUCTION KIT	DESCRIPTION	MODEL	WEIGHT Kg
	2" - 1" 1/2 REDUCTION KIT	EVOSTA 2 40-70/130 EVOSTA 2 40-70/180	0,1
		EVOSTA 3 40/130 - 60/130 - 80/130 EVOSTA 3 40/180 - 60/180 - 80/180	
		EVOPLUS 40/180 - 60/180 - 80/180 - 110/180	

INSULATION HOUSING KIT	DESCRIPTION	MODEL	WEIGHT Kg
	INSULATION HOUSING KIT *	EVOSTA 2 (All models)	0,6
		EVOSTA 3 (All models) * supplied as standard in the standar version	

POWER CONNECTOR	DESCRIPTION	MODEL	WEIGHT Kg
	EVOPLUS POWER CONNECTOR	EVOPLUS SMALL ()	0,1
	EVOSTA 3 ANGULAR CONNECTOR	EVOSTA 3	0,1

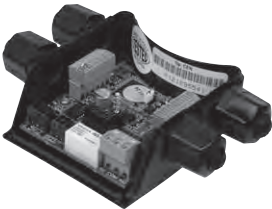
REMOTE CONTROL MODULE	DESCRIPTION	MODEL	WEIGHT Kg
 <p>EVOPLUS SMALL MULTI-FUNCTION MODULE</p>	EVOPLUS SMALL BASIC MODULE	EVOPLUS SMALL (All models) EVOPLUS SMALL SAN (All models)	0,5
	EVOPLUS SMALL MULTI-FUNCTION MODULE	EVOPLUS SMALL (All models) EVOPLUS SMALL SAN (All models) Supplied as standard on EvoPlus Small Twin models	0,5
	LON/MOD BUS CONVERTER MODULE	EVOPLUS SMALL (All models)	0,5
		EVOPLUS (All models)	0,5

BASIC MODULE

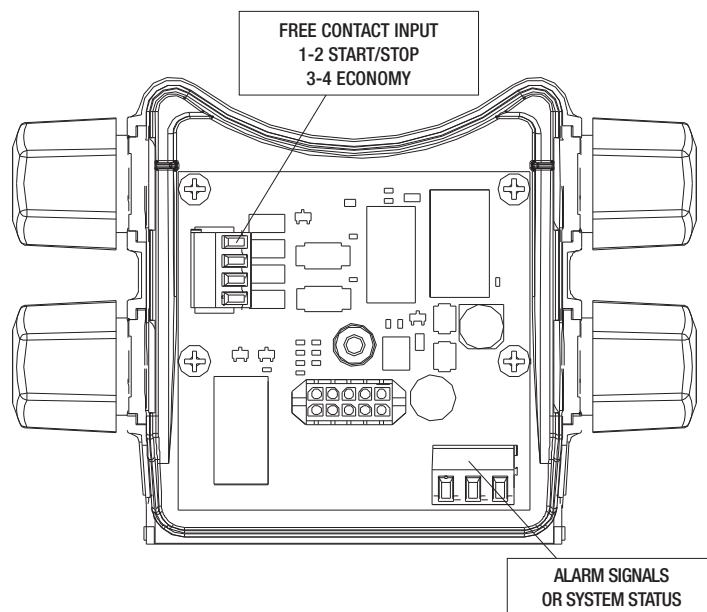

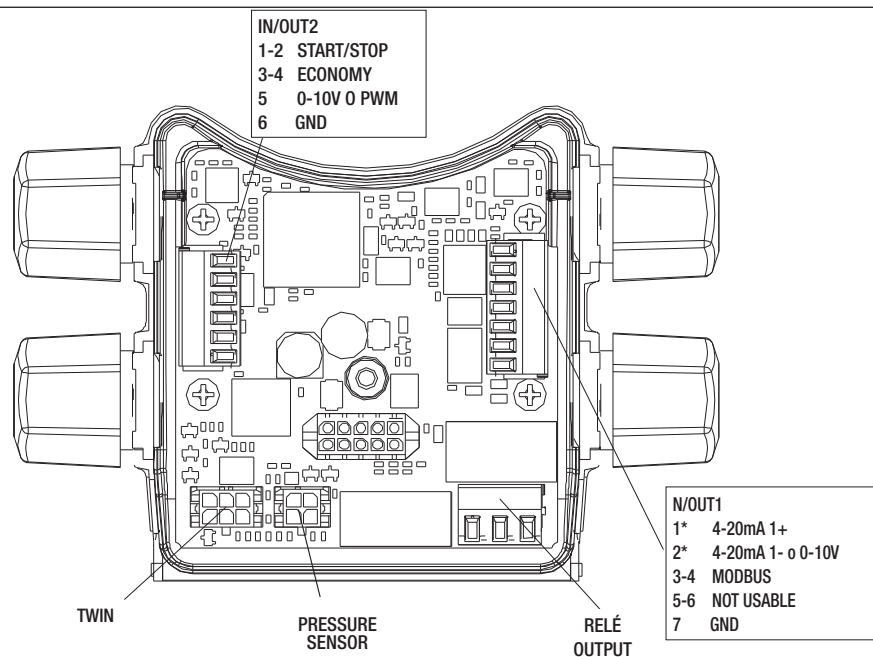

MULTI-FUNCTION MODULE



ACCESSORIES

CIRCULATORS

FLANGE KIT*	DESCRIPTION	MODEL	WEIGHT Kg
 <p>COUNTERFLANGE KIT DN50 PN 10</p>  <p>COUNTERFLANGE KIT DN 80 PN 16</p>	PN 10 DN 32 FLANGE KIT	EVOPLUS SMALL (All models) EVOPLUS (All models)	4,7
	DN 32 PN 10 AISI 304 FLANGE KIT	EVOPLUS SMALL SAN (All models) EVOPLUS SAN (All models)	4,7
	DN40 PN 10 FLANGE KIT	EVOPLUS SMALL (All models) EVOPLUS (All models) KLPE 40/600 - DKLPE 40/60 KLPE 40/1200 - DKLPE 40/1200 KLM 40/300 - DKLM 40/300 KLP 40/600 - DKLP 40/600 KLP 40/900 - DKLP 40/900 KLP 40/1200 - DKLP 40/1200 B 50/250.40 - B 56/250.40 - B 80/250.40 D 50/250.40 - D 56/250.40 - D 80/250.40 BMH-BPH WITH PUMP COUPLINGS DN 40	2,4
	DN 40 PN 10 AISI 304 FLANGE KIT	EVOPLUS SMALL SAN (All models) EVOPLUS SAN (All models)	2,5
	DN50 PN 10 FLANGE KIT	EVOPLUS (All models) KLME50/600 - DKLME 50/600 KLPE 50/1200 - DKLPE 50/1200 KLM 50/300 - DKLM 50/300 KLM 50/600 - DKLM 50/600 KLP 50/900 - DKLP 50/900 KLP 50/1200 - DKLP 50/1200 BMH-BPH WITH PUMP COUPLINGS DN 40	3,2
	DN 50 PN 10 AISI 304 FLANGE KIT	EVOPLUS SAN (All models)	3
	DN65 PN 10 FLANGE KIT	EVOPLUS (All models) KLME 65/600 - DKLME 65/600 KLPE 65/1200 - DKLPE 65/1200 KLM 65/300 - DKLM 65/300 KLM 65/600 - DKLM 65/600 KLP 65/900 - DKLP 65/900 KLP 65/1200 - DKLP 65/1200 BMH-BPH WITH PUMP COUPLINGS DN 40	4,0
	DN 65 PN 10 AISI 304 FLANGE KIT	EVOPLUS SAN (All models)	4
	DN80 PN 10 FLANGE KIT	EVOPLUS (All models) BPH - DPH (All models) KLME 80/600 - DKLME 80/600 KLPE 80/1200 - DKLPE 80/1200 KLM 80/300 - DKLM 80/300 KLM 80/600 - DKLM 80/600 KLP 80/900 - DKLP 80/900 KLP 80/1200 - DKLP 80/1200 BMH-BPH WITH PUMP COUPLINGS DN 40	4,8
	DN100 PN 10 FLANGE KIT	EVOPLUS (All models)	4,3
	DN 40 - PN 16 FLANGE KIT	CME 40 - CPE 40 - CM - CP 40	5,3
	DN 50 - PN 16 FLANGE KIT	CME 50 - CPE 50 - CM - CP 50	6,3
	DN 65 - PN 16 FLANGE KIT	CME 65 - CM-GE 65 - CP-GE 65 - CM 65 - CP 65	7,5
	DN 80 PN 16 FLANGE KIT	EVOPLUS (All models) CM-GE 80 - CP-GE 80 - CM 80 - CP 80	9,5
	DN 100 PN 16 FLANGE KIT	EVOPLUS (All models) CM-GE 100 - CP-GE 100 - CM 100 - CP 100	10,9
DN 125 - PN 16 FLANGE KIT	CM-GE 125 - CP-GE 125 - CM 125 - CP 125	14,5	
DN 150 - PN 16 FLANGE KIT	CM-GE 150 - CP-GE 150 - CM 150 - CP 150	18,6	



* The counterflange kit comprises: two counterflanges, nuts and bolts.

ACCESSORIES

CIRCULATORS

BLANK FLANGE KIT	DESCRIPTION	MODEL	WEIGHT Kg
	BLANK FLANGE KIT	(STD. FEATURE IN THE TWIN VERSION)	-
	DN 40 BLANK FLANGE KIT	BMH-BPH (STD. FEATURE IN THE TWIN VERSION)	-
	BLANK FLANGE KIT	BMH-BPH (STD. FEATURE IN THE TWIN VERSION)	-
	DN32 PN 10 BLANK FLANGE KIT - EVOPLUS S (STD. FEATURE IN THE TWIN VERSION)	EVOPLUS SMALL	4,7
	DN 32 PN 10 AISI 304 BLANK FLANGE KIT - EVOPLUS M&L (STD. FEATURE IN THE TWIN VERSION)	EVOPLUS MEDIUM & LARGE SAN	4,7

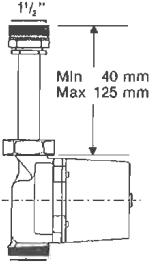
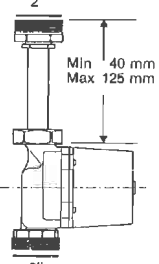
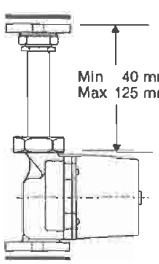
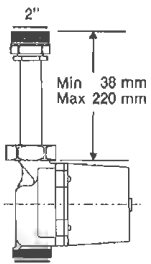
COMPENSATION KIT (FOR EVOPLUS)	DESCRIPTION	MODEL	WEIGHT Kg
 <p>COMPENSATION KIT</p>	COMPENSATION KIT FOR DN40 (30MM)	EVOPLUS (All models DN40)	2,5
	COMPENSATION KIT FOR DN50 (40MM)	EVOPLUS (All models DN50)	3,3

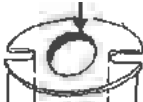
"QUICK SERVICE" ADAPTION KIT	DESCRIPTION	MODEL
	ADAPTATION KIT A - 1 1/2" EXTENSION	EVOSTA 2 40-70/130 - EVOSTA 2 40-70/180 EVOSTA 3 40/130 - EVOSTA 3 60/130 - EVOSTA 3 80/130 EVOSTA 3 40/180 - EVOSTA 3 60/180 - EVOSTA 3 80/180
	ADAPTATION KIT B - CONVERSION FROM 1 1/2" TO 2"	EVOSTA 2 40-70/130 - EVOSTA 2 40-70/180 EVOSTA 3 40/130 - EVOSTA 3 60/130 - EVOSTA 3 80/130 EVOSTA 3 40/180 - EVOSTA 3 60/180 - EVOSTA 3 80/180
	ADAPTATION KIT C - CONV. FROM 1 1/2" UNION TO DN 25 -DN 32 FL.	EVOSTA 2 40-70/130 - EVOSTA 2 40-70/180 EVOSTA 3 40/130 - EVOSTA 3 60/130 - EVOSTA 3 80/130 EVOSTA 3 40/180 - EVOSTA 3 60/180 - EVOSTA 3 80/180
	ADAPTATION KIT D - 2" EXTENSION	EVOSTA 3 40/180X - EVOSTA 3 60/180X - EVOSTA 3 80/180X
	ADAPTATION KIT E - 2" BRASS ADAPTER	EVOSTA 3 40/180X - EVOSTA 3 60/180X - EVOSTA 3 80/180X
	ADAPTATION KIT E - 1 1/2" BRASS ADAPTER	EVOSTA 2 40-70/130 - EVOSTA 2 40-70/180 EVOSTA 3 40/130 - EVOSTA 3 60/130 - EVOSTA 3 80/130 EVOSTA 3 40/180 - EVOSTA 3 60/180 - EVOSTA 3 80/180
	OVAL ADAP. KIT - DN 40	EVOSTA 2 40-70/130 - EVOSTA 2 40-70/180 EVOSTA 3 40/130 - EVOSTA 3 60/130 - EVOSTA 3 80/130 EVOSTA 3 40/180 - EVOSTA 3 60/180 - EVOSTA 3 80/180
	OVAL FLANGE KIT - DN 50	EVOSTA 3 40/180X - EVOSTA 3 60/180X - EVOSTA 3 80/180X

TECHNICAL APPENDIX

GENERAL INFORMATION

FUNDAMENTAL TERMS USED IN PUMPS

The following is a list of fundamental terms used in pumps and an explanation of their meanings. Their knowledge is necessary in order to discuss hydraulic pumps. All measurements are given in Technical units. Reference should be made to the chart for their international and Anglo-Saxon equivalents.

HEAD

Head means height, difference in level, gradient. For example if a pump has a flow of Q litres per second and a head of 30 metres, it means that it is capable of raising Q litres of liquid by 30 metres every second (therefore achieving a 30 metre gradient). For each given pump, the head is determined by its construction, such as the external diameter of the impeller and the speed of rotation, but it is not affected by the pumped liquid. This means that the pump as such can raise by 30 metres Q litres per second of water, petrol, mercury, etc.; the only difference in the three cases will be the power of the motor required.

SPECIFIC WEIGHT OF A LIQUID OR FLUID

The specific weight of a liquid or fluid is the weight per unit volume of the liquid/fluid. Specific weight is usually measured in kg/dm³ or kg/l, remembering that 1 dm³ equals 1 litre.

PRESSURE

Pressure means weight per unit of area (e.g. kg/cm²), and it should not be confused with head. In the case of liquids, the pressure that the liquid exerts on a surface is given by the product of the head (or height) of the liquid, multiplied by its specific weight. For this reason, the column of several km of air on the earth's surface produces at sea level a pressure of about 1kg/cm² (equal to approx. 1 atmosphere). If the same column were of water rather than air, the pressure would be some 700 to 800 times greater, due to the fact that water has a specific weight approximately 700-800 times greater than that of air.

Bearing in mind that a column of water 10 m high is equivalent to approx. 1 kg/cm², if we placed a manometer on the delivery of the pump, the following pressure increases would be measured:

- | | |
|--|---|
| a) with petrol (specific weight 0,7 kg/dm ³) | = 00,7 x 0,001 x 30 x 100 = 2,1 kg/cm ² |
| b) with water (specific weight 1,0 kg/dm ³) | = 00,1 x 0,001 x 30 x 100 = 3,0 kg/cm ² |
| c) with mercury (specific weight 13,6 kg/dm ³) | = 13,6 x 0,001 x 30 x 100 = 40,8 kg/cm ² |

FLOW

Flow means the quantity of liquid or fluid that passes through a point, such as the delivery outlet of a pump, or a cross section of a pipe, in the set unit of time.

This can be measured in litres per minute (l/min), litres per second (l/s), cubic metres per hour (m³/h) etc.

It should be noted that there is a perfect analogy between the flow of water through a pipe and the flow of electricity through a wire. It is sufficient to remember that hydraulic head is equivalent to electrical potential or voltage, and hydraulic flow is equivalent to electric current or amperes in electrotechnics. Even their behaviour is the same. Just as a thin wire restricts the flow of electricity more than one with a larger section, in the same way, a pipe of a smaller diameter offers a greater resistance to the flow of a liquid than one of a larger one. Just as the passage of electric current through the wire to a cable needs a voltage difference, in the same way, the flow of a liquid or fluid through a pipe needs a certain head.

There will never be a movement of liquid between two points of a perfectly horizontal pipe, and with the liquid at the same head in both points. This is due to the fact that, in the same way as the cable exerts a certain resistance to the passage of the electric current (electric resistance), the pipe also exerts a certain resistance to the passage of the fluid, the extent of which depends on the quality of the pipe (material, shape, presence of scale) and its section, and therefore the speed at which the fluid runs through the pipe. This resistance is called head loss.

HEAD LOSS

Head loss is that part of the head, possessed by the liquid, which is lost when passing through a pipe, a valve, a filter, etc. This loss cannot be recovered, as it is lost due to friction. Going back to the analogy between electrical and hydraulic phenomena, just as the losses in a cable increase in proportion with the current, so head losses are proportionally greater as the speed of the liquid increases. This means that the more the flow is restricted by scaled pipes, clogged filters, partially closed valves etc. the greater the head loss will be.

PUMP

A pump is a machine used to give a certain head to a liquid that passes through it. The head can be used to raise the liquid to a higher level, or to make it flow inside a pipe, or even in the open air, so that it covers a certain distance. The characteristics of a pump are:

- a) **Flow** (the quantity of liquid that is moved through the pump in a unit of time)
- b) **Head** (that is the height at which the pump is capable lifting the flow)

Based on the existing relationship between the flow and the head, it is possible to have:

- a) Pumps with small flow and large head (piston pumps, rotary pumps, small centrifugal pumps).
- b) Pumps with medium flow and medium head (centrifugal pumps in general).
- c) Pumps with large flow and small head (helico-centrifugal pumps, propeller pumps).

Centrifugal pumps, helico-centrifugal pumps and propeller pumps have a rotary motion and their speed is universally measured in revolutions per minute

(rpm). With these machines operating at a given speed, for each given value of flow, there is only one value of head. This means that in order to increase or decrease the performance of these types of pumps, the operating speed must be varied accordingly. Basically, the liquid passing through the pump is supplied with energy that is related to the head and the speed of the liquid itself. This energy supplied within the unit of time is known as delivered power.

DELIVERED POWER

The delivered power is the power delivered by the pump to the liquid. The value of this delivered power depends on three factors: flow, head, and specific weight of the pumped liquid. The higher these three factors, the higher is the power delivered by the pump. For example, a pump delivering petrol does less work than when delivering sulphuric acid, because the specific weights of the two liquids are different.

In order to pump a liquid, a pump must be driven by a motor. In the vast majority of cases, this is either an electric, or an internal combustion motor. Electric motors use electric power, while internal combustion motors (engines) use oil or oil derivative fuels. The power that the pump needs in order to operate is called absorbed power.

DELIVERED POWER CALCULATION

Delivered power is normally expressed in kW or HP, indicating with:

Q = the flow

H = the head in metres of the column of liquid (m.c.l.)

γ = the specific weight of the liquid

The delivered power (P3) is calculated using one of the following equations:

$$P3 = \frac{\gamma \text{ (kg/dm}^3\text{)} \times Q \text{ (l/s)} \times H \text{ (m.c.l.)}}{75} \text{ in HP}$$

$$P3 = \frac{\gamma \text{ (kg/dm}^3\text{)} \times Q \text{ (m}^3\text{/h)} \times H \text{ (m.c.l.)}}{270} \text{ in HP}$$

$$P3 = \frac{\gamma \text{ (kg/dm}^3\text{)} \times Q \text{ (l/s)} \times H \text{ (m.c.l.)}}{102} \text{ in kW}$$

$$P3 = \frac{\gamma \text{ (kg/dm}^3\text{)} \times Q \text{ (l/min)} \times H \text{ (m.c.l.)}}{4500} \text{ in HP}$$

$$P3 = \frac{\gamma \text{ (kg/dm}^3\text{)} \times Q \text{ (m}^3\text{/h)} \times H \text{ (m.c.l.)}}{367} \text{ in kW}$$

$$P3 = \frac{\gamma \text{ (kg/dm}^3\text{)} \times Q \text{ (l/min)} \times H \text{ (m.c.l.)}}{6120} \text{ in kW}$$

ABSORBED POWER

Absorbed power is the power that the pump absorbs from the motor, to give to the liquid the delivered power discussed above.

Not all the absorbed power becomes delivered power, as some power is lost through friction, and even more within the pump itself, due to hydraulic losses. It is therefore clear that the delivered power is always less than the absorbed power, and the relation between the two is a number always lower than 1. This number is known as the efficiency.

YIELD

The efficiency is obtained by dividing the delivered power by the absorbed power, and is normally expressed as a percentage. For example, an efficiency of 75 % of a pump indicates that only 75 % of the absorbed power is converted into delivered power, with the remaining 25 % being lost due to friction. Therefore, the higher the efficiency of a pump, the smaller the portion of absorbed power being lost. If one then considers that the cost of energy relates to the absorbed power, it immediately becomes apparent just how important efficiency is. If we compare two pumps with the same 1 HP delivered power, but with an efficiency of 50 % for the first, and 60 % for the second, we can assume that the first one will need 2 HP to supply 1, while the second will only need 1,67 HP to achieve the same result. This means that the efficiency of a pump expresses, better than any other parameter, the quality of the pump and the related savings in terms of operating costs.

CALCULATION OF POWER OUTPUTS

P1: is the power absorbed by the motor in kW (generally indicated by the wattmeter).

P2: the power delivered by the motor in kW. This is measured at the brake (it basically is the power absorbed by the pump).

P3: the power delivered by the pump in kW.

$$\text{Power output of the motor } \eta = \frac{P_2}{P_1}$$

$$\text{Power output of the motor } \eta = \frac{P_3}{P_2}$$

$$\text{Power output of the motor } \eta = \frac{P_3}{P_1}$$

THE HEAD OF A PUMP AND ITS MEASUREMENT

The head of a pump is always the differential head, or that given by the pump itself. This is generally expressed in metres. In order to ascertain the head of a surface pump, during its operation it is necessary to measure the value of the head both at the suction and at the delivery of the pump itself, making sure that the readings are taken at the same level, which is called the reference plane. Two cases are possible, depending on installation:

- 1) the value of the head at the suction is negative (i.e. below zero shown on the manometer): in this case, the level of the liquid collected is lower than the level of the suction inlet.
- 2) the value of the head at the suction is positive (i.e. above zero shown on the manometer) in this case, the level of the liquid collected is higher than the level of the suction inlet (flooded suction).

In the first case the head of the pump is given by the sum of the two readings, while in the second it is given by subtracting the value of the head at the suction inlet from the value at the delivery outlet.

Finally, it is necessary to make sure that the readings at the suction and the delivery have been taken from apertures of the same diameter, so that they are not distorted by a difference in the speed of the liquid at the point of measurement. Any correction is made by calculating the dynamic head, or that part of the head linked with the speed of the liquid, which means that part of the head that the liquid possesses at the measuring section, due to the fact that it is moving. The dynamic head H_d , expressed in metres, is calculated using the following formula:

$$H_d = \frac{v^2}{2g}$$

where: v = speed of the fluid at the measuring point, given in m/s

g = acceleration of gravity (9,81), expressed in m/s^2

$2g = 2 \times 9,81 = 19,62 \text{ m/s}^2$

The correction of the head is given by the difference between the dynamic head at the delivery, and the dynamic head at the suction. It is therefore clear that if the readings upstream and downstream the pump have been taken on pipes of the same diameter, and therefore with the liquid flowing at the same speed, the correction is zero.

To find the head of submersible impeller pumps, it is sufficient, during operation, to measure the head at the delivery port. In this case, the head of the pump is then given by adding the value read to the dynamic head (at the delivery outlet), and to the difference in level between the free surface of the liquid collected and the manometer.

VARIATION IN PUMP HEAD IN RELATION TO SPEED VARIATION

The performance of a pump is directly connected to its speed in rpm (n). Providing that there is no cavitation, the law of similarity may be used, which is expressed as follows:

$$Q_x = Q \times \frac{n_x}{n}$$

$$H_x = H \times \left(\frac{n_x}{n}\right)^2$$

$$P_{2-x} = P_2 \times \left(\frac{n_x}{n}\right)^3$$

For example, when doubling the number of revolutions (n_x) one obtains:

Q_x = the value of the flow doubles

H_x = the value of the head is 4 times higher

P_{2-x} = the value of the absorbed power is 8 times higher

$Q - H - P_2$ are the values at speed n

$Q_x - H_x - P_{2-x}$ are the values at speed n_x .

NOTES ON THE MOTORS OF ELECTRIC PUMPS

INDEX OF SYMBOLS USED	
P_1	: POWER ABSORBED BY THE MOTOR IN KW.
P_2	: POWER DELIVERED BY THE MOTOR IN KW OR HP.
$V \sim$	= AC POWER INPUT VOLTAGE AT THE MAINS.
Hz	= FREQUENCY IN CYCLES PER SECOND OF THE POWER INPUT VOLTAGE.
I	= CURRENT ABSORBED BY THE MOTOR IN AMPERES.
$\cos\phi$	= POWER FACTOR.
$n^{1/min}$	= SPEED OF ROTATION IN RPM.
η	= OUTPUT POWER (RELATION BETWEEN DEVELOPED POWER AND ABSORBED POWER P_2/P_1).
p	= NUMBER OF POLES OF THE MOTOR.
C_n	= NOMINAL TORQUE OF THE MOTOR.

NO-LOAD SPEED OF ROTATION

The no-load speed of single-phase and three-phase electric induction motors is given by the formula:

$$n^{1/min} = \frac{120 \times \text{Hz}}{p}$$

No-load speed of rotation $n^{1/min}$

FREQUENCY Hz	2 POLES	4 POLES
50	3000	1500
60	3600	1800

The full-load speed is 2 to 7 % lower than the no-load speed (2 to 7 % sliding).

CURRENT ABSORBED

$$\text{Single-phase: } I = \frac{1000 \times P_2 \text{ (kW)}}{V \times \cos\phi \times \eta} \quad \text{or: } I = \frac{736 \times P_2 \text{ (HP)}}{V \times \cos\phi \times \eta}$$

$$\text{Three-phase: } I = \frac{1000 \times P_2 \text{ (kW)}}{1.73 \times V \times \cos\phi \times \eta} \quad \text{or: } I = \frac{736 \times P_2 \text{ (HP)}}{1.73 \times V \times \cos\phi \times \eta}$$

ABSORBED POWER

$$\text{Single-phase: } P_1 \text{ (kW)} = \frac{V \times I \times \cos\phi}{1000}$$

$$\text{Three-phase: } P_1 \text{ (kW)} = \frac{1.73 \times V \times I \times \cos\phi}{1000}$$

POWER DELIVERED AT THE MOTOR AXIS

$$\text{Single-phase: } P_2 \text{ (kW)} = \frac{V \times I \times \cos\phi \times \eta}{1000} \quad \text{or: } P_2 \text{ (HP)} = \frac{V \times I \times \cos\phi \times \eta}{736}$$

$$\text{Three-phase: } P_2 \text{ (kW)} = \frac{1.73 \times V \times I \times \cos\phi \times \eta}{1000} \quad \text{or: } P_2 \text{ (HP)} = \frac{1.73 \times V \times I \times \cos\phi \times \eta}{736}$$

YIELD

$$\eta = \frac{P_2 \text{ (kW)}}{P_1 \text{ (kW)}}$$

POWER FACTOR

$$\text{Single-phase: } \cos\varphi = \frac{P_2 (\text{kW}) \times 1000}{V \times I \times \eta}$$

$$\text{or: } \cos\varphi = \frac{P_1 (\text{kW}) \times 1000}{V \times I}$$

$$\text{Three-phase: } \cos\varphi = \frac{P_2 (\text{kW}) \times 1000}{1,73 \times V \times I \times \eta}$$

$$\text{or: } \cos\varphi = \frac{P_1 (\text{kW}) \times 1000}{1,73 \times V \times I}$$

TORQUE FACTOR

$$C_n = \frac{P_2 (\text{kW}) \times 1000}{1.027 \times n^{1/\text{min}}} \text{ in kgm}$$

$$C_n = \frac{P_2 (\text{HP}) \times 736}{1.027 \times n^{1/\text{min}}} \text{ in kgm}$$

$$C_n = \frac{702 \times \text{HP}}{n^{1/\text{min}}} \text{ in decaNewtonmetres}$$

RELATIONSHIP BETWEEN KW AND HP

$$1 \text{ HP} = 0,736 \text{ kW}$$

$$1 \text{ kW} = 1,36 \text{ HP}$$

$$\frac{\text{HP}}{1.36} = \text{kW}$$

$$\text{kW} \times 1,36 = \text{HP}$$

STARTING CURRENT (ISP)

The starting current (at switch on) of a motor is 4 to 8 times greater than the nominal current, depending on the power of the motor.

$$I_{sp} = I_n \times 4 \div 8$$

DETAILS ON CAPACITORS

The approximate current absorbed by a capacitor is:

$$I = \frac{6,28 \times F \times C \times V}{1.000.000}$$

Where:

I = current in Amps absorbed by the capacitor.

F = frequency in Hz of the applied voltage.

C = capacity of capacitor μF .

V = applied voltage.

Example:

The current absorbed by a 14 μF capacitor connected to a 220 Volt - 50 Hz power input is:

$$I = \frac{6,28 \times 50 \times 14 \times 220}{1.000.000} = 0,96 \text{ Amperes}$$

The approximate capacity of a capacitor is determined by:

$$C = \frac{I}{6,28 \times F \times V} \times 1,000,000$$

Example:

The capacity of a capacitor absorbing 1,4 Amps connected to a 220 Volt - 50 Hz power input is:

$$C = \frac{1,4}{6,28 \times 50 \times 220} \times 1,000,000 = 20,2 \mu\text{F}$$

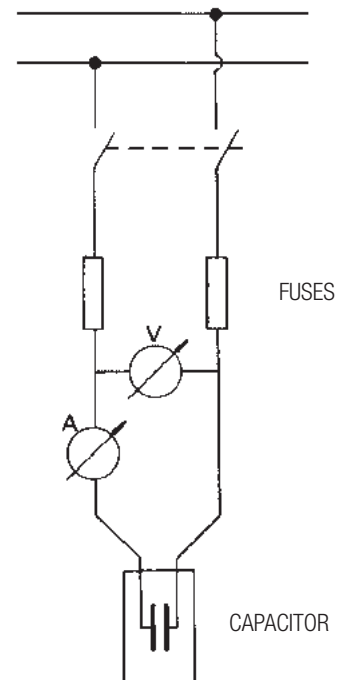

STAR-DELTA START-UP

The normally delta Δ connected motor is connected to the network using a star type connection. The current and the starting torque are both reduced to 1/3 of the value they would be if delta Δ connected.

PROTECTION

It is recommended that motors are connected to the power input network using appropriate three-fuse thermal magnetic circuit breakers, or in any case circuit breakers complying with current local regulations.

LOAD LOSS AND SPEED TABLE

In order to accurately calculate **load losses and speed**, the following table is used:

FLOW			NEW GALVANISED PIPING									
			NOMINAL DIAMETERS: INCHES AND MM									
l/s	l/min	m³/h	1/2"	3/4"	1"	1"1/4	1"1/2	2"	2"1/2	3"	3"1/2	4"
			15,75	21,25	27	35,75	41,25	52,5	68	80,25	92,5	105
0,17	10	0,6	0,856	0,47	0,291							
			9,01	20,9	0,65							
0,25	15	0,9	1,284	0,705	0,4387	0,249						
			19,07	4,43	1,38	0,35						
0,33	20	1,2	1,712	0,94	0,582	0,332	0,25					
			32,47	7,55	2,35	0,6	0,3					
0,42	25	1,5	2,14	1,175	0,728	0,415	0,31					
			49,06	11,41	3,55	0,91	0,45					
0,5	30	1,8	2,568	1,411	0,874	0,498	0,37	0,23				
			68,74	15,98	4,98	1,27	0,63	0,2				
0,58	35	2,1	2,996	1,646	1,019	0,581	0,44	0,27				
			91,42	21,26	6,62	1,69	0,84	0,26				
0,67	40	2,4		1,881	1,165	0,664	0,5	0,31				
				27,22	8,48	2,16	1,08	0,33				
0,83	50	3		2,351	1,456	0,831	0,62	0,39	0,23			
				41,13	12,81	3,27	1,63	0,5	0,14			
1	60	3,6		2,821	1,747	0,997	0,75	0,46	0,28			
				57,63	17,95	4,58	2,28	0,7	0,2			
1,17	70	4,2		3,291	2,039	1,163	0,87	0,54	0,32	0,23		
				76,64	23,88	6,08	3,03	0,94	0,27	0,12		
1,33	80	4,8			2,33	1,329	1	0,62	0,37	0,26		
					30,57	7,79	3,88	1,2	34	0,15		
1,5	90	5,4			2,621	1,495	1,12	0,69	0,41	0,3		
					38,01	9,69	4,83	1,49	0,42	0,19		
1,67	100	6			2,912	1,661	1,25	0,77	0,46	0,33	0,25	
					46,19	11,77	5,86	1,81	0,51	0,23	0,11	
2,08	125	7,5			3,641	2,077	1,56	0,96	0,57	0,41	0,31	0,24
					69,79	17,79	8,86	2,74	0,78	0,35	0,17	0,09
2,5	150	9				2,492	1,87	1,16	0,69	0,49	0,37	0,29
						24,92	12,41	3,84	1,09	0,49	0,24	0,13
2,92	175	10,5				2,907	2,18	1,35	0,8	0,58	0,43	0,34
						33,15	16,51	5,1	1,45	0,65	0,32	0,17

White numbers: Load losses in m. for every 100 m of pipework

Green numbers: Water speed in m/sec

The table refers to galvanised pipework.

For other materials multiply as follows:

- 0,6 PVC pipes.
- 0,7 aluminium pipes.
- 0,8 laminated steel and stainless steel.

LOAD LOSS AND SPEED TABLE

In order to accurately calculate **load losses and speed**, the following table is used:

FLOW			NEW GALVANISED PIPING										
			NOMINAL DIAMETERS: INCHES AND MM										
l/s	l/min	m³/h	1"1/4	1"1/2	2"	2"1/2	3"	3"1/2	4"	5"	6"	8"	
			35,75	41,25	52,5	68	80,25	92,5	105	130	155	206	
3,33	200	12	3,322	2,5	1,54	0,92	0,66	0,5	0,39	0,25			
			42,43	21,14	6,53	1,85	0,83	0,41	0,22	0,08			
4,17	250	15	4,156	3,12	1,93	1,15	0,82	0,62	0,48	0,31			
			64,12	31,94	9,87	2,8	1,25	1,63	0,34	0,12			
5	300	18	3,74	2,31	1,38	0,99	0,74	0,58	0,38	0,27			
			44,75	13,83	3,92	1,75	0,88	0,47	0,17	0,07			
6,67	400	24	4,99	3,08	1,84	1,32	0,99	0,77	0,5	0,35			
			76,2	23,55	6,68	2,98	1,49	0,8	0,28	0,12			
8,33	500	30	3,85	2,3	1,65	1,24	0,96	0,63	0,44				
			35,58	10,09	4,51	2,26	1,22	0,43	0,18				
10	600	36	4,62	2,75	1,98	1,49	1,16	0,75	0,53	0,3			
			49,85	14,14	6,31	3,16	1,7	0,6	0,26	0,06			
11,67	700	42	3,21	2,31	1,74	1,35	0,88	0,62	0,35				
			18,81	8,4	4,2	2,27	0,8	0,34	0,09				
13,33	800	48	3,67	2,64	1,99	1,54	1,01	0,71	0,4				
			24,08	10,75	5,38	2,9	1,03	0,44	0,11				
15	900	54	4,13	2,97	2,23	1,73	1,13	0,8	0,45				
			29,94	13,37	6,69	3,61	1,28	0,54	0,14				
16,67	1000	60	4,59	3,3	2,48	1,93	1,26	0,88	0,5				
			36,39	16,24	8,13	4,39	1,55	0,66	0,16				
20,83	1250	75	4,12	3,1	2,41	1,57	1,1	0,63					
			24,54	12,29	6,63	2,34	0,99	0,25					
25	1500	90	4,95	3,72	2,89	1,88	1,33	0,75					
			34,39	17,22	9,29	3,28	1,39	0,35					
29,17	1750	105	4,34	3,37	2,2	1,55	0,88						
			22,9	12,35	4,37	1,85	0,46						
33,33	2000	120	4,96	3,85	2,5	1,77	1						
			29,31	15,81	5,59	2,37	0,59						
41,67	2500	150	4,81	3,14	2,21	1,25							
			23,89	8,44	3,59	0,9							
50	3000	180	HAZEN WILLIAMS CALCULATION FORMULA (UNI 9489 13.3.3.6)				3,77	2,65	1,5				
							11,83	5,02	1,26				
5,03	3,53	2											
20,15	8,55	2,14											
83,33	5000	300					4,42	2,5					
							12,93	3,23					

White numbers: Load losses in m. for every 100 m of pipework

Green numbers: Water speed in m/sec

The table refers to galvanised pipework.

For other materials multiply as follows:

- 0,6 PVC pipes.
- 0,7 aluminium pipes.
- 0,8 laminated steel and stainless steel.

HEAD LOSS

in cm of column of water in bends, gate valves, and foot valves

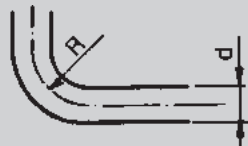
VELOCITY OF WATER IN m/s	SHARP EDGED BENDS					NORMAL BENDS					GATE VALVE	FOOT VALVE	NON-RETURN VALVE	HEAD LOSS ON EXIT FROM PIPES $V^2 \cdot 2G$
														
	$\alpha = 30^\circ$	$\alpha = 40^\circ$	$\alpha = 60^\circ$	$\alpha = 80^\circ$	$\alpha = 90^\circ$	$\frac{d}{R} = 0,4$	$\frac{d}{R} = 0,6$	$\frac{d}{R} = 0,8$	$\frac{d}{R} = 1$	$\frac{d}{R} = 1,5$				
0,10	0,03	0,04	0,05	0,07	0,08	0,07	0,08	0,01	0,0155	0,027	0,03	30	30	0,05
0,15	0,06	0,73	0,1	0,14	0,17	0,016	0,019	0,024	0,033	0,06	0,033	31	31	0,12
0,2	0,11	0,13	0,18	0,26	0,31	0,028	0,033	0,04	0,059	0,11	0,058	31	31	0,21
0,25	0,17	0,21	0,28	0,4	0,48	0,044	0,052	0,063	0,091	0,17	0,09	31	31	0,32
0,3	0,25	0,3	0,41	0,6	0,7	0,063	0,074	0,09	0,13	0,25	0,13	31	31	0,46
0,35	0,33	0,4	0,54	0,8	0,93	0,085	0,10	0,12	0,18	0,33	0,18	31	31	0,62
0,4	0,43	0,52	0,71	1,0	1,2	0,11	0,13	0,16	0,23	0,43	0,23	32	31	0,82
0,5	0,67	0,81	1,1	1,6	1,9	0,18	0,21	0,26	0,37	0,67	0,37	33	32	1,27
0,6	0,97	1,2	1,6	2,3	2,8	0,25	0,29	0,36	0,52	0,97	0,52	34	32	1,84
0,7	1,35	1,65	2,2	3,2	3,9	0,34	0,40	0,48	0,70	1,35	0,7	35	32	2,5
0,8	1,7	2,1	2,8	4,0	4,8	0,45	0,53	0,64	0,93	1,7	0,95	36	33	3,3
0,9	2,2	2,7	6	5,2	6,2	0,57	0,67	0,82	1,18	2,2	1,2	37	34	4,2
1,0	2,7	3,3	4,5	6,4	7,6	0,7	0,82	1,0	1,45	2,7	1,45	38	35	5,1
1,5	6,0	7,3	10,0	14,0	17,0	1,6	1,9	2,3	3,3	6,0	3,3	47	40	11,5
2,0	11,0	14,0	18,0	26,0	31,0	2,8	3,3	4,0	5,8	11,0	5,8	61	48	20,4
2,5	17,0	21,0	28,0	40,0	48,0	4,4	5,2	6,3	9,1	17,0	9,1	78	58	32,0
3,0	25,0	30,0	41,0	60,0	70,0	6,3	7,4	9,0	13,0	25,0	13,0	100	71	46,0
3,5	33,0	40,0	55,0	78,0	93,0	8,5	10,0	12,0	18,0	33,0	18,0	123	85	62,0
4,0	43,0	52,0	70,0	100,0	120,0	11,0	13,0	16,0	23,0	42,0	23,0	150	100	82,0
4,5	55,0	67,0	90,0	130,0	160,0	14,0	21,0	26,0	37,0	55,0	37,0	190	120	103,0
5,0	67,0	82,0	110,0	160,0	190,0	18,0	29,0	36,0	52,0	67,0	52,0	220	140	127,0

v = velocity of water in metres per second

d = diameter of pipes in m metres

h = head loss in cm of water column for each metre of pipework, calculated according to the Lang formula:

$$h = \lambda \times \frac{100}{d} \times \frac{v^2}{2g} \qquad \lambda = 0,02 + \frac{0,0018}{\sqrt{v \times d}}$$

The only loss in bends is that due to the contraction of the liquid stream when changing direction (the development of the curves must therefore be included in the length of the pipework); the head loss for gate valves has been determined through technical tests.

The head loss for gate valves and normal bends is equal to that of 5 m of straight pipework, while that of non-return valves is equal to 15 m.

The values given are for pipes with a completely smooth internal surface. In case of rough or scaled pipes, allowances must be made accordingly.

VAPOUR TENSION AND SPECIFIC WEIGHT OF WATER AS A FUNCTION OF TEMPERATURE

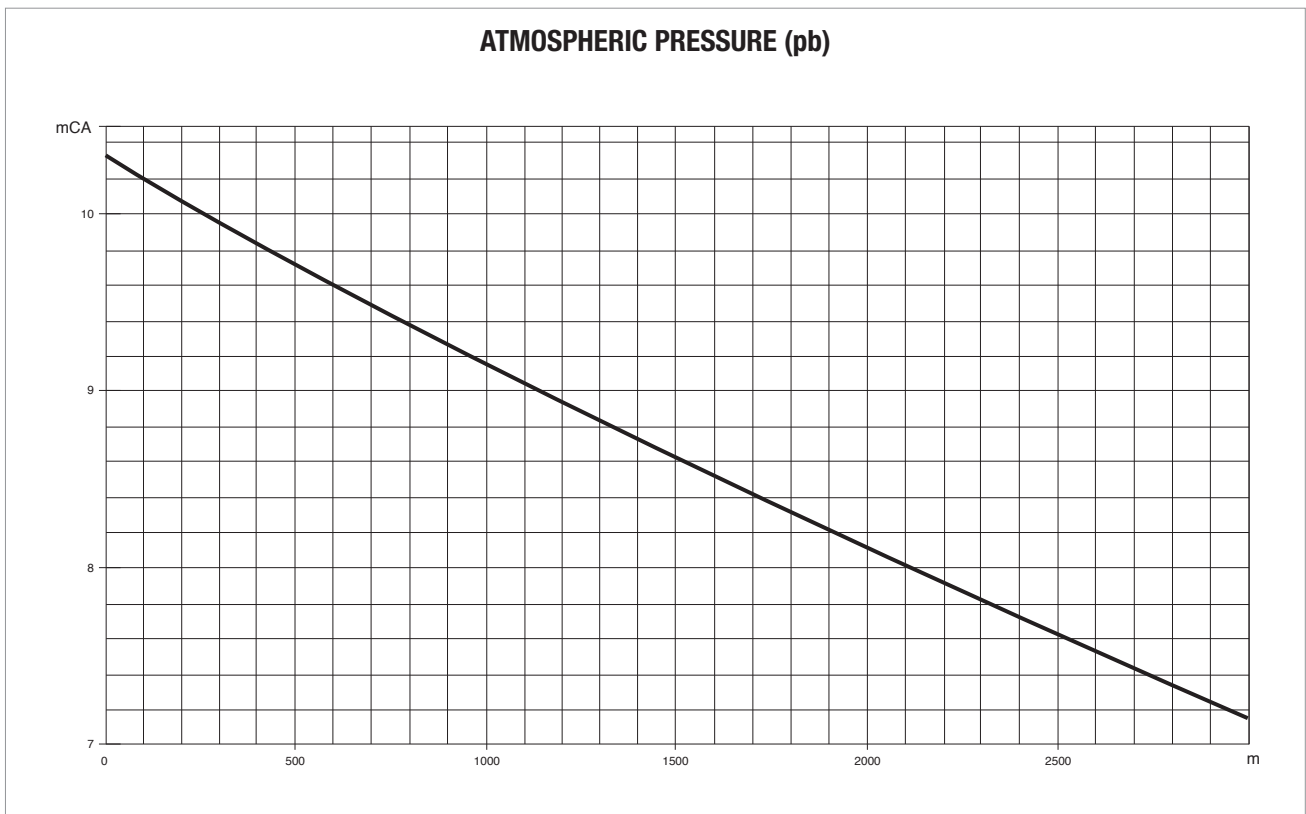
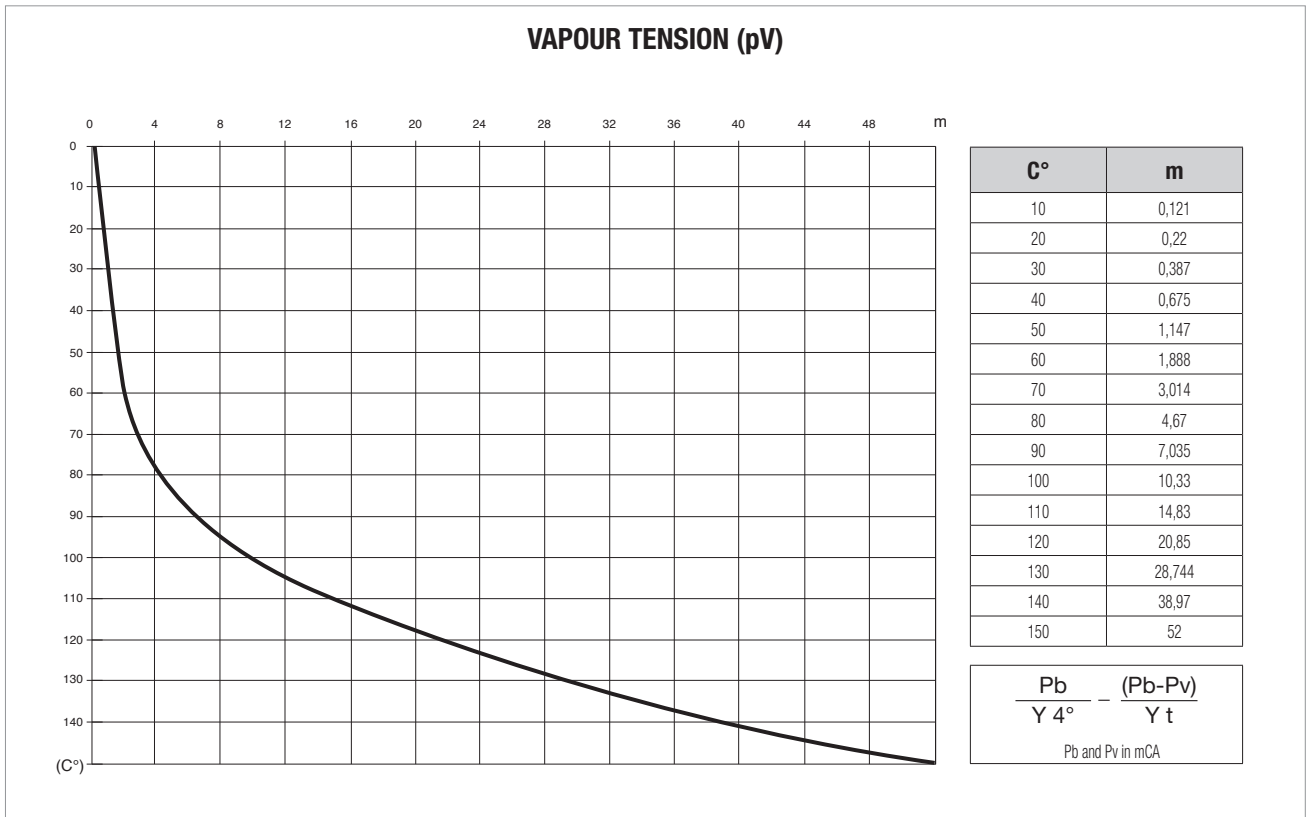

CONVERSION TABLE FOR UNITS OF MEASURE



CHARACTERISTIC	SYSTEM UNIT OF MEASURE	UNIT OF MEASURE	SYMBOL	CONVERSIONS		
				SYSTEM	INTERNATIONAL SYSTEM (SI)	IMPERIAL SYSTEM
LENGTH	Technical and International	metre decimetre centimetre millimetre	m dm cm mm	1 dm = 0,1 m 1 cm = 0,01 m 1 mm = 0,001 m		1 m = 3,28 ft 1 dm = 3,937 in 1 cm = 0,3937 in
	Imperial	inch foot yard	1", in 1", ft yd	1" = 25,4 mm 1" ft = 0,3048 m 1 yd = 0,9144 m		1 ft = 12" 1 yd = 3 ft = 26"
AREA	Technical and International	metres squared centimetres squared millimetres squared	m ² cm ² mm ²	1 cm ² = 0,0001 m ² 1 mm ² = 0,01 cm ²		1 m ² = 1,196 sq.yd 1 m ² = 10,764 sq.ft 1 cm ² = 0,155 sq.in
	Imperial	square inch square foot square yard	sq.in sq.ft sq.yd	1 sq.in = 6,45 cm ² 1 sq.ft = 0,0929 m ² 1 sq.yd = 0,836 m ²		1 sq.ft = 144 sq.in 1 sq.yd = 1,296 sq.in 1 sq.yd = 9 sq.ft
VOLUME	Technical and International	metre cubed decimetre cubed centimetre cubed litre cubed	m ³ cm ³ mm ³ l	1 m ³ = 1.000 dm ³ 1 cm ³ = 0,001 m ³ = 1.000 cm ³ 1 mm ³ = 0,001 dm ³ 1 l = dm ³		1 dm ³ = 0,22 Imp.gal 1 dm ³ = 0,264 US.gal 1 dm ³ = 61,0 cu.in
	Imperial	cubic inch cubic feet Imperial gallons U.S. gallons	cu.in cu.ft Imp.gal USA.gal	1 cu.in = 16,39 cm ³ 1 cu.ft = 28,34 m ³ 1 Imp.gal = 4,546 m ³ 1 US.gal = 3,785 dm ³		1 Imp.gal = 1,201 US.gal 1 US.gal = 0,833 Imp.gal
TEMPERATURE	Technical and International	degrees Centigrade degrees Kelvin	°C °K	°C = °K - 273 °K = °C + 273		°C = 5/9 x (°F - 32) °K = 5/9 x (°F - 32) + 273
	Imperial	degrees Fahrenheit	°F	°F = 9/5 x °C + 32		-
		freezing point of water at atmospheric pressure: boiling point of water at atmospheric pressure:		000°C = 273 °K = 032 °F 100°C = 373 °K = 212 °F		
WEIGHT and FORCE	Technical	kilogram	kg	-	1 kg = 9,81 N	1 kg = 2,203 lb
	International	Newton	N	1 N = 0,102 kg	-	1 N = 0,22546 lb
	Imperial	pound	lb	1 lb = 0,454 kg	1 lb = 4,452 N	-
SPECIFIC WEIGHT	Technical	kilogram per decimetre cubed	kg/dm ³	-	1 kg/dm ³ = 9,807 N/dm ³	1 kg/dm ³ = 62,46 lb/cu.ft
	International	Newton per decimetre cubed	N/dm ³	1 N/dm ³ = 0,102 kg/dm ³	-	1 N/dm ³ = 6,36 lb/cu.ft
	Imperial	pound per cubic foot	lb/dm ³	1 lb/cu.ft = 0,01600 kg/dm ³	1 lb/cu.ft = 0,160 N/dm ³	-
PRESSURE	Technical	atmospheres	kg/cm ²	-	1 kg/cm ² = 98,067 kPa 1 kg/cm ² = 0,9807 bar	1 kg/cm ² = 14,22 psi
	International	Pascal kiloPascal bar	Pa kPa bar	1 kPa = 0,0102 kg/cm ² 1 bar = 1,02 kg/cm ²	1 kPa = 1.000 Pa 1 bar = 100.000 Pa	1 kPa = 0,145 psi 1 bar = 14,50 psi
	Imperial	pounds per square inch	psi	1 psi = 0,0703 kg/cm ²	1 psi = 0,06895 bar 1 psi = 6,894 kPa	-
FLOW	Technical	litres per minute litres per second metres cubed per hour	l/min l/s m ³ /h	1 l/min = 0,0167 l/s 1 l/s = 3,6 m ³ /h 1 m ³ /h = 16,667 l/min	1 l/s = 0,001 m ³ /s	1 l/min = 0,22 imp.g.p.m. 1 l/min = 0,264 US.g.p.m. 1 m ³ /h = 3,666 imp.g.p.m. 1 m ³ /h = 4,403 US.g.p.m.
	International	metres cubed per second	m ³ /s	1 m ³ /s = 1.000 l/s 1 m ³ /s = 3.600 m ³ /h	-	1 m ³ /s = 13,198 imp.g.p.m. 1 m ³ /s = 15,852 US.g.p.m.
	Imperial	imperial gallons per minute U.S. gallons per minute	Imp.g.p.m. US.g.p.m.	1 Imp.g.p.m. = 4,546 l/min 1 Imp.g.p.m. = 0,273 m ³ /h 1 US.g.p.m. = 3,785 l/min 1 US.g.p.m. = 0,227 m ³ /h	-	1 Imp.g.p.m. = 1,201 US.g.p.m. 1 US.g.p.m. = 0,833 Imp.g.p.m.
TORQUE	Technical	kilogram metre	kgm	-	1 kgm = 9,807 Nm	1 kgm = 7,233 ft.lb
	International	Newton metre	Nm	1 Nm = 0,102 kgm	-	1 Nm = 0,7376 ft.lb
	Imperial	foot pound	ft.lb	1 ft.lb = 0,138 kgm	1 ft.lb = 1,358 Nm	-
WORK and ENERGY	Technical	kilogram metre vapour-horsepower hour	kgm CVh		1 kgm = 9,807 J 1 CVh = 0,736 kWh	1 kgm = 7,233 ft.lb 1 Nm = 0,986 HP.hr.
	International	Joule kiloWatt hour	J kWhq	1 J = 0,102 kgm kWh = 1,36 CVh	-	1 Nm = 0,7376 ft.lb 1 Nm = 0,7376 ft.lb
	Imperial	foot pound Horsepower hour	ft.lb HP.hr.	1 ft.lb = 0,138 kgm 1 HP.hr. = 1,014 CVh	1 ft.lb = 0,358 Nm 1 HP.hr. = 0,746 kWh	-
POWER	Technical	Horse power	HP	1 HP = 0,736 kW	1 HP = 736 W	-
	International	Watt kiloWatt	W kW	1 W = 0,00136 Hp 1 kW = 1,36 Hp	1 kW = 1.000 W	-
KINETIC VISCOSITY	Technical	stokes centistokes	1 St 1 cSt	1 St = 1 cm ² /s 1 cSt = 0,01 St	1 St = 0.0001 m ² /s	1 St = 0.00107 ft ² /s
	International	m ² /s	m ² /s	1 m ² /s = 10.000 St	1 m ² /s = 10.000 cm ² /s	1 m ² /s = 10.764 ft ² /s
	Imperial	square foot per second	ft ² /s	1 ft ² /s = 929 St	1 ft ² /s = 0.0929 m ² /s	-



EVOPLUS MENU CONFIGURATION

The settings are completed by passing from one page to the next in the configuration menu of the circulator.

The Home Page shows a chart summary of the system settings. The top left icon indicates the type of regulation selected.

The top centre icon indicates the mode of operation selected (auto or economy).

The top right icon indicates the presence of a single  or twin inverter 

The rotation of the  or  icon shows which circulation pump is in operation. At the centre of the Home Page is a display only parameter that can be selected, among a small set of parameters, using Page 9.0 of the menu.



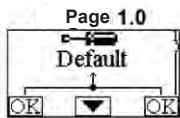

From the **Home Page**, it is possible to access the display **contrast adjustment** page: press and hold down the hidden key while pressing and releasing the right key. EVOPLUS SMALL circulators provide a user menu that can be accessed from the Home Page by pressing and releasing the "Menu" central key.

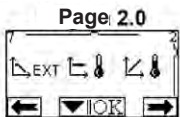

Using **Page 1.0**, it is possible to reset the factory settings by pressing the left and the right key at the same time for 3 seconds. The resetting to the factory settings will be notified with the appearance of the  symbol by the "Default" indication.



Using **Page 2.0**, it is possible to set the control mode. The following control modes are available:

1.  = Proportional differential pressure control mode.
2.  = Constant differential pressure control mode.
3.  = Constant curve control mode with rotation speed set through the display.

Page 2.0 shows 3 icons that represent:

central icon = currently selected setting

right icon = next setting

left icon = previous setting

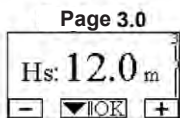

Using **Page 3.0**, it is possible to modify the regulation set-point. Depending on the type of control mode selected in the previous page, the set-point to set will be a head or, in the case of constant curve, a percentage of the rotation speed.

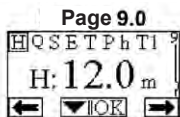

Using **page 9.0**, it is possible to select the parameter to display in the Home Page:

H : Estimated head in metres

Q : Estimated flow rate in m³/h

S : Rotation speed in revolutions per minute (rpm)

E : Not present

P : Power delivered in W

h : Hours of operation

T : Not present

T1 : Not present

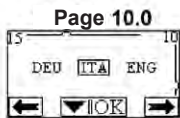

Using **page 10.0**, it is possible to select the message display language.

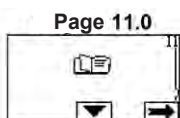

Using **page 11.0**, it is possible to display the alarm log by pressing the right key.

Any faults are permanently recorded by the system in the alarm log (for a maximum of 15 alarms). For each alarm recorded, a page consisting of 3 sections is displayed: an alphanumeric code that identifies the type of fault, a symbol providing a graphic representation of the fault, and lastly a short message describing the fault in the language selected on Page 10.0.

Press the right key to scroll through all the log pages.

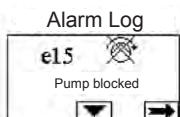

At the end of the log are 2 questions:

1. **"Reset Alarms?"** - Press OK (left key) to reset any alarms still found in the system.
2. **"Delete the Alarm Log?"** - Press OK (left key) to delete any alarms recorded in the log.

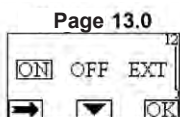

Using **page 13.0**, it is possible to switch the system ON or OFF.

If ON is selected, the pump is always switched on.

If OFF is selected, the pump is always switched off.

DESCRIPTION OF DISPLAYED MEASUREMENTS

Symbol	Description
H Q S E T P h T1	Parameter display
H	Head in metres
Q	Flow rate in m ³ /h $Q < Q_{min}$ when Q is 30% lower than Q_{max} $Q = 0$ only when Evoplus is off
S	Speed in revolutions/minute (rpm)
E	0-10V or PWM analogue input (with multifunction module)
T	Liquid temperature in °C - input D (with multifunction module and thermal probe)
P	Power in kW
h	Hours of operation
T1	Liquid temperature in °C - input C (with multifunction module and thermal probe)
T _{Hs}	Liquid temperature in °C depending on the regulation (with multifunction module and thermal probe)

CIRCULATOR STATUS

Symbol	Description
	Single circulator or circulator no. 1
	Circulator no. 2
	Alternate twin circulators
	Main/backup twin circulators (switch every 24 hours)
	Simultaneous twin circulators
ON	Circulator on
OFF	Circulator off
EXT	Circulator controlled by remote signal (ref. terminals 1-2)

OPERATING MODE

Symbol	Description
auto	Auto mode
	Economy mode

TYPES OF REGULATIONS

Symbol	Description
	Δp -c regulation (constant pressure)
	Δp -c regulation based on the temperature (during implementation).
	Δp -v regulation (variable pressure).
	Δp -v regulation based on the temperature (during implementation).
	Regulation with head set through the display.
	Regulation with head set by remote 0-10 V signal.
ΔT -c	ΔT -c regulation (constant temperature)













MISCHELLANEOUS

Symbol	Description
	Control panel blocked
	Multifunction key for the confirmation of the parameters, and page scrolling.











FACTORY SETTINGS

Parameter	Value
Mode of regulation	Parameter display
Hs (Differential Pressure Set-point)	Δp -v
Operating modes	auto
Set-point reduction percentage	50 %
Twin operating modes	= Alternate every 24 hours
Pump start command	EXT (from remote signal)

TYPES OF ALARMS AND RESOLUTION

Alarm Code	Alarm Symbol	Alarm Description
e0 - e16; e21		Internal Error
e17 - e19		Short Circuit
e20		Voltage Error
e22 - e31		Internal Error
e32 - e35		Electronic system overtemperature
e37		Low voltage
e38		High voltage
e39 - e40		Pump blocked
e46		Pump disconnected
e42		Dry operation.
e56		Motor overtemperature
e57		Frequency of the PWM external signal lower than 100 Hz
e58		Frequency of the PWM external signal higher than 5 kHz

ERROR AND RESET CONDITIONS

Error condition			
Display indication		Description	Reset
e0 - E16		Internal error	<ul style="list-style-type: none"> - Disconnect the power input voltage to the system. - Wait for the control panel LEDs to turn off, and then reconnect the power input to the system. - If the error persists, replace the circulator.
e37		Low network voltage (LP)	<ul style="list-style-type: none"> - Disconnect the power input voltage to the system. - Wait for the control panel LEDs to turn off, and then reconnect the power input to the system. - Check that the network voltage is correct. If necessary reset it to the plate details.
e38		High network voltage (HP)	<ul style="list-style-type: none"> - Disconnect the power input voltage to the system. - Wait for the control panel LEDs to turn off, and then reconnect the power input to the system. - Check that the network voltage is correct. If necessary reset it to the plate details.
e32-e35		Critical overheating of electronic parts	<ul style="list-style-type: none"> - Disconnect the power input voltage to the system. - Wait for the control panel LEDs to turn off. - Check that the system ventilation conduits are not obstructed and that the local ambient temperature is within the specifications.
e39-e40		Current overload protection	<ul style="list-style-type: none"> - Check that the circulator is turning freely. - Check that the antifreeze added does not exceed the maximum amount of 30 %.
e21-e30		Voltage Error	<ul style="list-style-type: none"> - Disconnect the power input voltage to the system. - Wait for the control panel LEDs to turn off, and then reconnect the power input to the system. - Check that the network voltage is correct. If necessary reset it to the plate details.
e31		Twin communication not found	<ul style="list-style-type: none"> - Check that the communication cable is not damaged. - Check that both circulators can be powered.
e42		Dry operation.	<ul style="list-style-type: none"> - Put the system under pressure
e56		Motor overtemperature	<ul style="list-style-type: none"> - Disconnect the power input voltage to the system. - Wait for the motor to cool down. - Reconnect the power input voltage to the system.
e57-e58		f < 100 Hz ; f > 5 kHz	<ul style="list-style-type: none"> - Check that the external PWM signal is working and connected as per the specification.

TECHNICAL APPENDIX

EVOPLUS SMALL / EVOPLUS SMALL SAN

TYPE OF INSTALLATION:

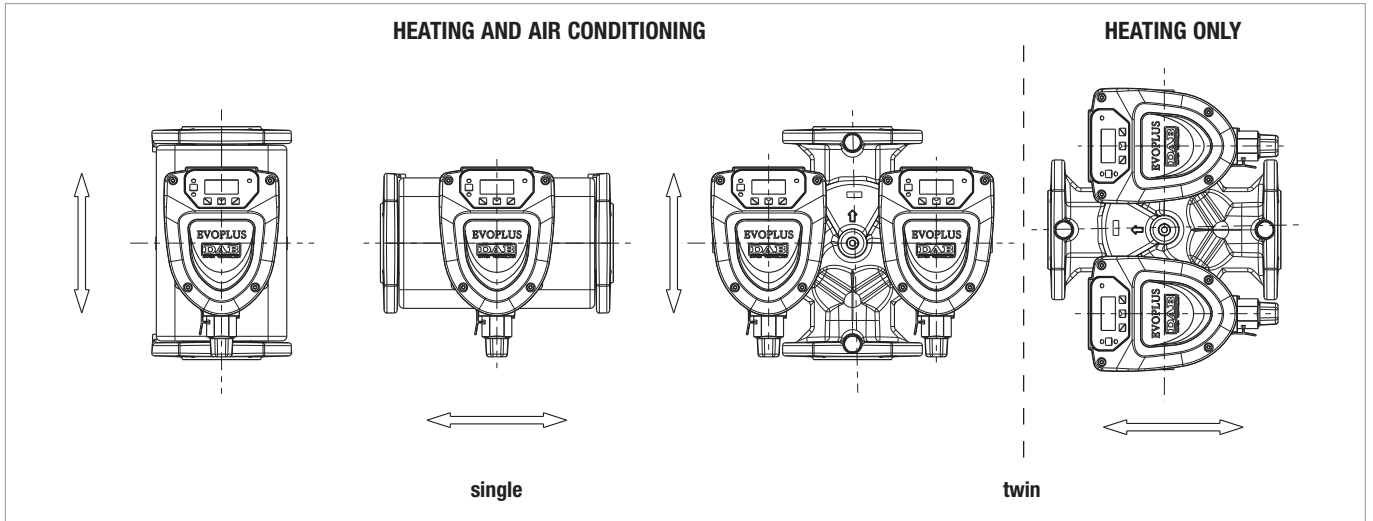

CONNECTION DIAGRAM

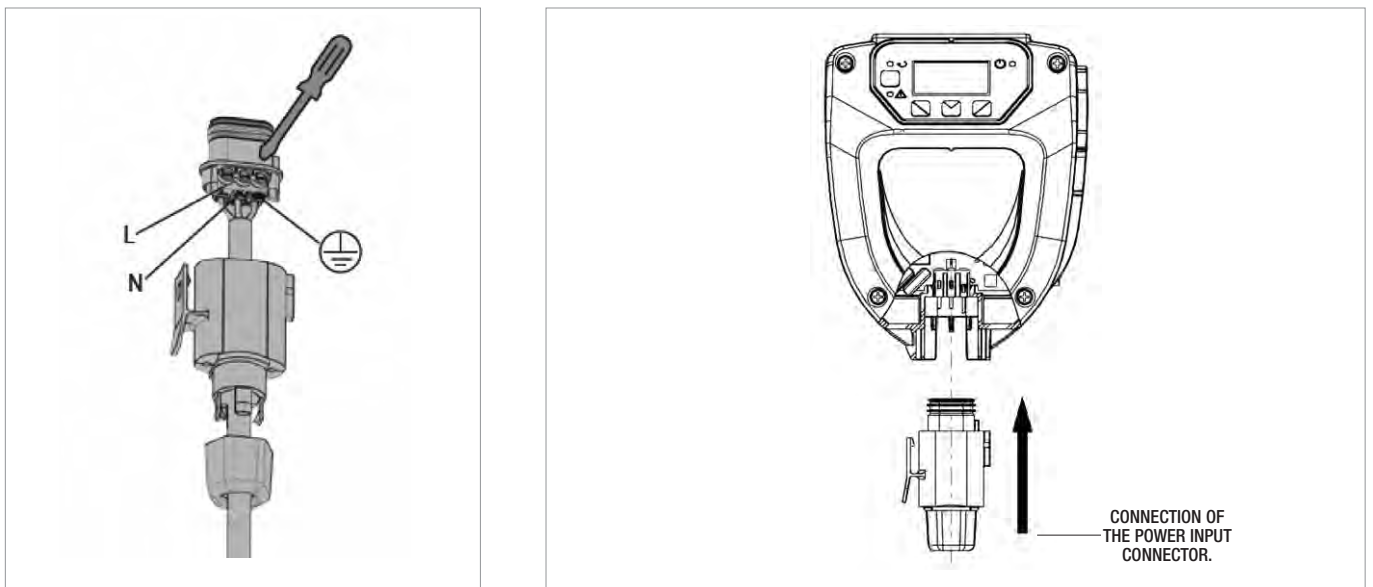

CONTROL PANEL

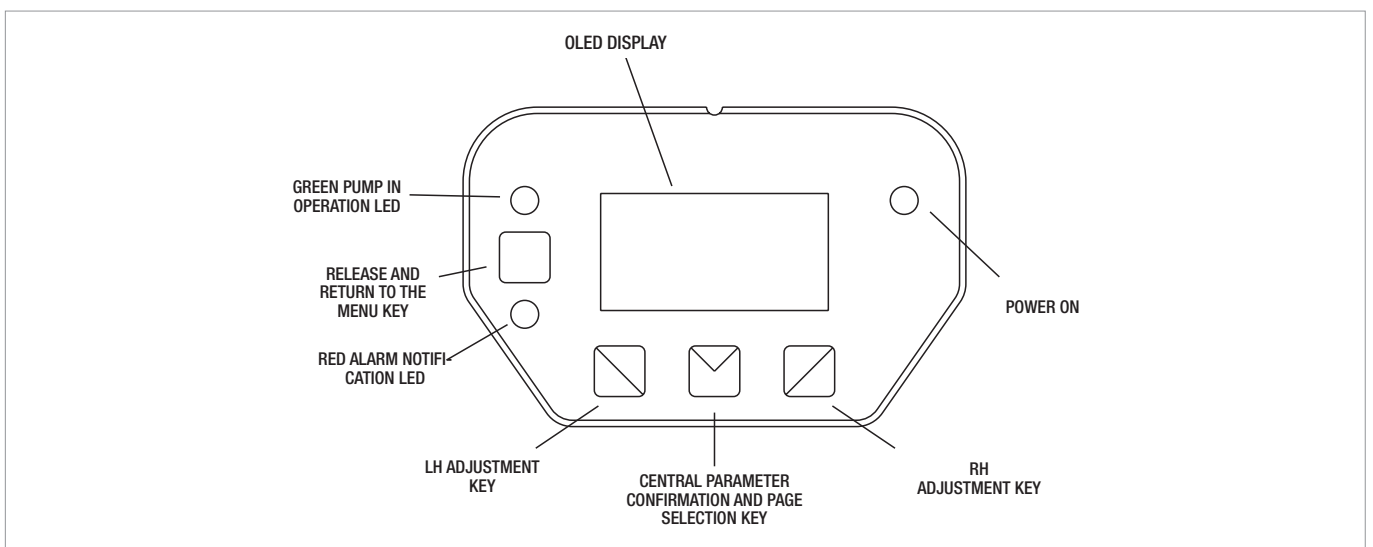

EVOPLUS MENU CONFIGURATION

The settings are completed by passing from one page to the next in the configuration menu of the circulator.



The Home Page shows a chart summary of the system settings.

The top left icon indicates the type of regulation selected.

The top centre icon indicates the mode of operation selected (auto or economy).

The top right icon indicates the presence of a single ① or twin inverter ②/①

The rotation of the ① or ② icon shows which circulation pump is in operation

At the centre of the Home Page is a display only parameter that can be selected, among a small set of parameters, using Page 9.0 of the menu.

From the **Home Page**, it is possible to access the display contrast adjustment page: press and hold down the hidden key while pressing and releasing the right key.

EVOPLUS circulators offer the option of 2 menus: user menu and advanced menu. The user menu can be accessed from the Home Page by pressing and releasing the central "Menu" key.

The advanced menu can be accessed from the Home Page by pressing the central "Menu" key for 5 seconds.

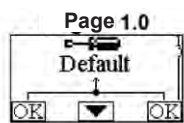

Using **Page 1.0**, it is possible to reset the factory settings by pressing the left and the right key at the same time for 3 seconds.

The resetting to the factory settings will be notified with the appearance of the symbol by the "Default" indication.

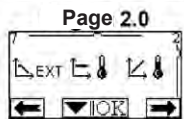

Using **Page 2.0**, it is possible to set the control mode. The following control modes are available:

1. = Proportional differential pressure control mode.
2. = Proportional differential pressure control mode with set-point set by external signal (0-10V or PWM).
3. = Proportional differential pressure control mode with set-point based on the temperature.
4. = Constant differential pressure control mode.
5. = Constant differential pressure control mode with set-point set by external signal (0-10V or PWM).
6. = Constant differential pressure control mode with set-point based on the temperature.
7. = Constant curve control mode with rotation speed set through the display.
8. = Constant curve control mode with rotation speed set by external signal (0-10V or PWM).

Page 2.0 shows 3 icons that represent:

central icon = currently selected setting

right icon = next setting

left icon = previous setting

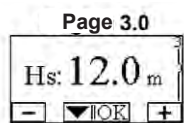

Using **Page 3.0**, it is possible to modify the regulation set-point.

Depending on the type of control mode selected in the previous page, the set-point to set will be a head or, in the case of constant curve, a percentage of the rotation speed.

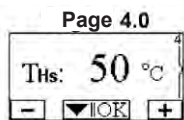

Using **Page 4.0** it is possible to modify the THs parameter with which to produce the temperature dependence curve (see par. 10.1.4).

This page will only be displayed for the regulations based on the temperature of the liquid.

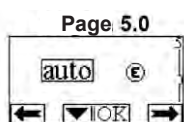

Page 5.0 can be used to set the mode of operation, "auto" or "economy".

"Auto" mode disables the reading of the status of the IN2 digital input, and in effect the system always implements the set-point set by the user.

"Economy" mode enables the reading of the status of the IN2 digital input.

When input IN2 is energised, the system applies a percentage reduction to the set-point set by the user (page 6.0 of the EVOPLUS menu).

For the connection of the inputs see par. 8.2.1

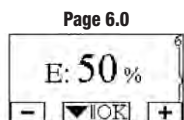

Page 6.0 is displayed if "economy" mode has been selected in page 5.0. It gives the possibility of setting the set-point value as a percentage.

This reduction will be performed if input IN2 is energised.

Page 7.0

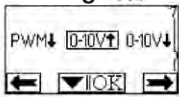

Page 7.0 is displayed if a mode of operation with set-point regulated by external signal has been selected. This page gives the possibility of selecting the type of control signal: analogue 0-10 V (positive or negative increase), or PWM (positive or negative increase).

Page 8.0

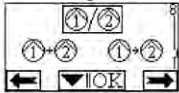

When using a twin system (see par. 8.3), using **page 8.0** it is possible to set one of the 3 possible twin modes of operation:

- Alternate every 24 hours:** The 2 circulators alternate in performing the adjustment functions at intervals of 24 hours of operation. If one becomes faulty, the other one takes over the adjustment operations.
- Simultaneous:** The 2 circulators both work at the same time, and at the same speed. This mode is useful when a flow rate that cannot be delivered by one single pump is required.
- Main/Backup:** The adjustment is always performed by the same circulator (Main); the other one (Backup) only intervenes when the Main one becomes faulty. If the twin communication cable is disconnected, the systems configure themselves automatically as single, working fully independently from each other.

If the twin communication cable is connected, the systems are automatically configured as individual, working in a full independent way from each other.

Page 9.0



Using **page 9.0**, it is possible to select the parameter to display in the Home Page:

- H** Measured head in metres.
- Q** Estimated flow rate in m³/h
- S** Rotation speed in revolutions per minute (rpm)
- E** Head requested by the external 0-10 V or PWM signal, if active.
- P** Power delivered in kW.
- h** Hours of operation
- T** Liquid temperature measured by the on-board sensor.
- T1** Liquid temperature measured by external sensor.

Page 10.0

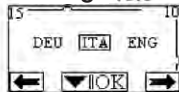

Using **page 10.0**, it is possible to select the message display language.

Page 11.0

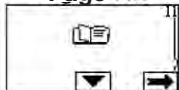

Using **page 11.0**, it is possible to display the alarm log by pressing the right key.

Any faults are permanently recorded by the system in the alarm log (for a maximum of 15 alarms). For each alarm recorded, a page consisting of 3 sections is displayed: an alphanumeric code that identifies the type of fault, a symbol providing a graphic representation of the fault, and lastly a short message describing the fault in the language selected on Page 10.0.

Alarm Log



Press the right key to scroll through all the log pages. At the end of the log are 2 questions:

1. **"Reset Alarms?"** Press OK (left key) to reset any alarms still found in the system.
2. **"Delete the Alarm Log?"** Press OK (left key) to delete any alarms recorded in the log.

Page 12.0

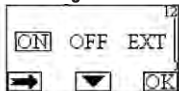

Using **page 12.0**, it is possible to set the system as ON, OFF, or controlled by EXT remote signal (digital input IN1).

If ON is selected, the pump is always switched on.

If OFF is selected, the pump is always switched off.

If EXT is selected, the reading of the status of digital input IN1 is enabled. When input IN1 is energised, the system turns ON and the pump starts (at the bottom right of the Home Page, "EXT" and "ON" will flash in succession); when input IN1 is not energised, the system turns OFF and the pump stops (at the bottom right of the Home Page, "EXT" and "OFF" will flash in succession).

DESCRIPTION OF DISPLAYED MEASUREMENTS

Symbol	Description
H Q S E T P h T1	Parameter display
H	Head in metres
Q	Flow rate in m ³ /h $Q < Q_{\min}$ when Q is 30% lower than Q_{\max} $Q = 0$ only when Evoplus is off
S	Speed in revolutions/minute (rpm)
E	0-10 V or PWM analogue input
T	Liquid temperature in °C - input D
P	Power in kW
h	Hours of operation
T1	Liquid temperature in °C - input C (available with additional thermal probe)
T _{Hs}	Liquid temperature in °C depending on the regulation

CIRCULATOR STATUS

Symbol	Description
①	Single circulator or circulator no. 1
②	Circulator no. 2
②/①	Alternate twin circulators
②↔①	Main/backup twin circulators (switch every 24 hours)
②+①	Simultaneous twin circulators
ON	Circulator on
OFF	Circulator off
EXT	Circulator controlled by remote signal (ref. terminals 1-2)



OPERATING MODE

Symbol	Description
auto	Auto mode
ⓔ	Economy mode



TYPES OF REGULATIONS

Symbol	Description
	Δp -c regulation (constant pressure)
	Δp -c regulation based on the temperature
	Δp -v regulation (variable pressure).
	Δp -v regulation based on the temperature.
	Regulation with head set through the display.
	Regulation with head set by remote 0-10 V signal.
ΔT -c	ΔT -c regulation (constant temperature)















MISCHELLANEOUS

Symbol	Description
	Control panel blocked
 	Parameter confirmation and page scrolling multifunction key









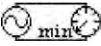

FACTORY SETTINGS

Parameter	Value
Mode of regulation	Parameter display
Hs (Differential Pressure Set-point)	
Operating modes	auto
Set-point reduction percentage	50 %
Twin operating modes	 = Alternate every 24 hours
Pump start command	EXT (from remote signal)

TYPES OF ALARMS AND RESOLUTION

Alarm Code	Alarm Symbol	Alarm Description
e0 - e16; e21		Internal Error
e17 - e19		Short Circuit
e20		Voltage Error
e22 - e31		Internal Error
e32 - e35		Electronic system overtemperature
e37		Low voltage
e38		High voltage
e39 - e40		Pump blocked
e43 - e44 - e45 - e54		Pressure Sensor
e46		Pump disconnected
e42		Dry operation.
e56		Motor over-temperature (triggering of the overload protection)
e57		Frequency of the PWM external signal lower than 100 Hz
e58		Frequency of the PWM external signal higher than 5 kHz

ERROR AND RESET CONDITIONS

Error condition			
Display indication		Description	Reset
e0 - E16		Internal error	<ul style="list-style-type: none"> - Disconnect the power input voltage to the system. - Wait for the control panel LEDs to turn off, and then reconnect the power input to the system. - If the error persists, replace the circulator.
e37		Low network voltage (LP)	<ul style="list-style-type: none"> - Disconnect the power input voltage to the system. - Wait for the control panel LEDs to turn off, and then reconnect the power input to the system. - Check that the network voltage is correct. - If necessary reset it to the plate details.
e38		High network voltage (HP)	<ul style="list-style-type: none"> - Disconnect the power input voltage to the system. - Wait for the control panel LEDs to turn off, and then reconnect the power input to the system. - Check that the network voltage is correct. If necessary reset it to the plate details.
e32-e35		Critical overheating of electronic parts	<ul style="list-style-type: none"> - Disconnect the power input voltage to the system. - Wait for the control panel LEDs to turn off. - Check that the system ventilation conduits are not obstructed and that the local ambient temperature is within the specifications.
e43-e45-e54		No sensor signal	<ul style="list-style-type: none"> - Check the connection of the sensor - Replace the sensor, if faulty
e39-e40		Current overload protection	<ul style="list-style-type: none"> - Check that the circulator is turning freely. - Check that the antifreeze added does not exceed the maximum amount of 30 %.
e21-e30		Voltage Error	<ul style="list-style-type: none"> - Disconnect the power input voltage to the system. - Wait for the control panel LEDs to turn off and then reconnect the power input to the system. - Check that the network voltage is correct. - If necessary reset it to the plate details.
e31		Twin communication not found	<ul style="list-style-type: none"> - Check that the communication cable is not damaged. - Check that both circulators can be powered.
e42		Dry operation.	<ul style="list-style-type: none"> - Put the system under pressure
e56		Motor overtemperature	<ul style="list-style-type: none"> - Disconnect the power input voltage to the system. - Wait for the motor to cool down. - Reconnect the power input voltage to the system.
e57-e58		$f < 100 \text{ Hz}$; $f > 5 \text{ kHz}$	<ul style="list-style-type: none"> - Check that the external PWM signal is working and connected as per the specifications.

TYPE OF INSTALLATION:

HEATING AND AIR CONDITIONING

HEATING ONLY

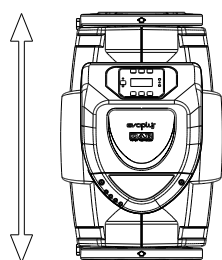

single

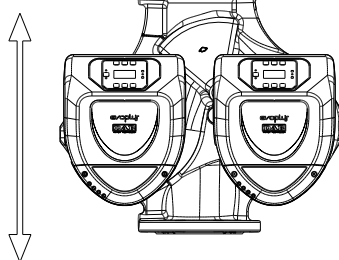
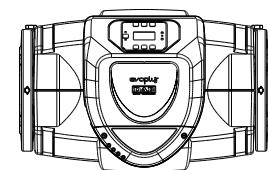

twin

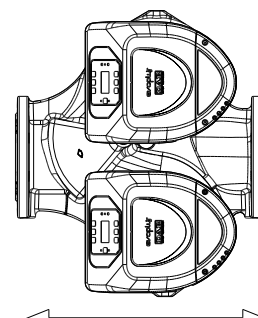

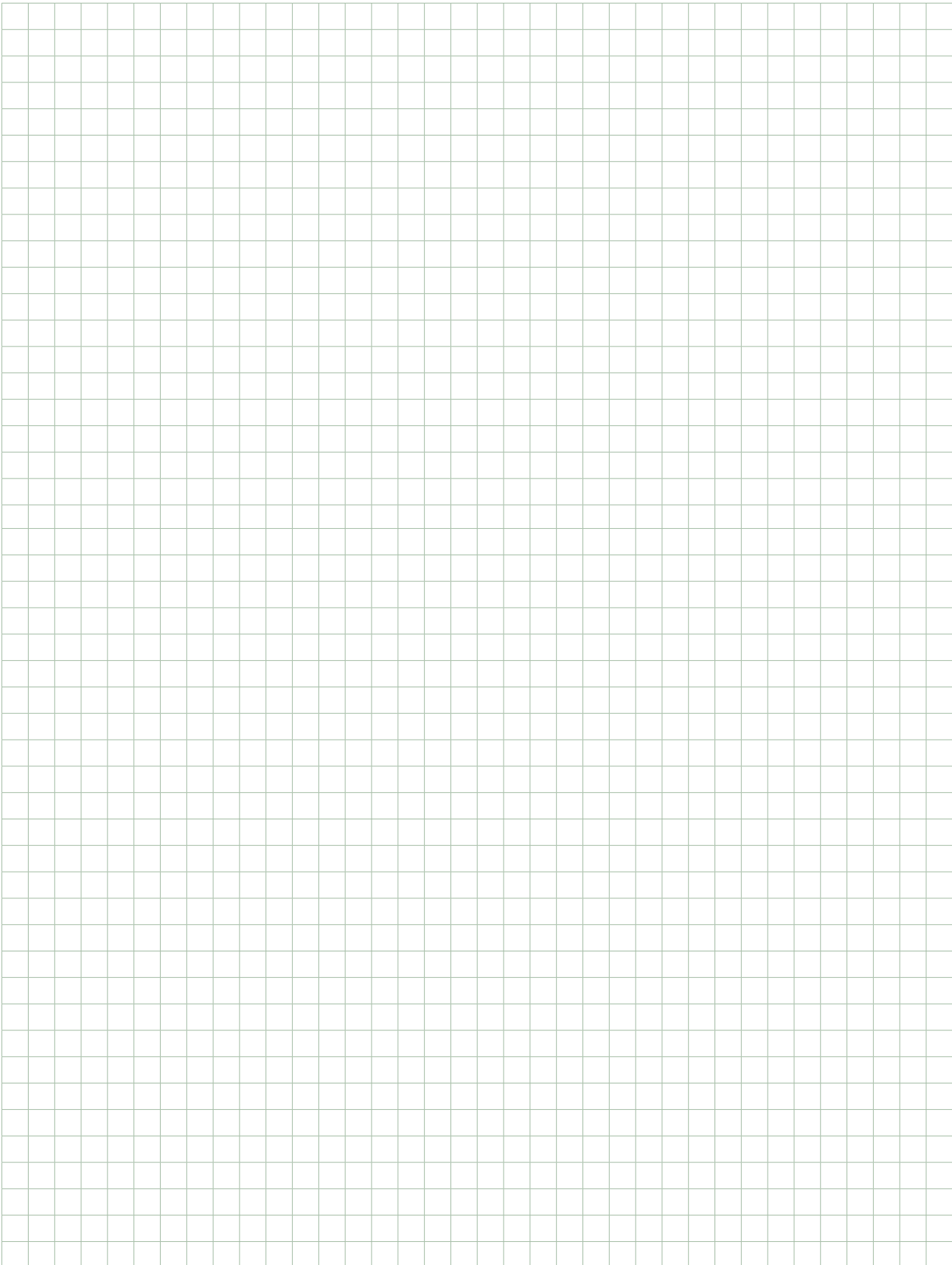

NOTES

A large grid of graph paper for taking notes, consisting of approximately 30 columns and 45 rows of small squares.



DAB

PUMPS SELECTOR

On-line product selection



 **DAB PUMPS LTD.**
6 Gilbert Court
Newcomen Way
Severalls Business Park
Colchester
Essex
CO4 9WN - UK
salesuk@dwtgroup.com
Tel. +44 0333 777 5010

 **DAB PUMPS IBERICA S.L.**
Calle Verano 18-20-22
28850 - Torrejón de Ardoz - Madrid
Spain
Info.spain@dwtgroup.com
Tel. +34 91 6569545
Fax: +34 91 6569676

 **DAB PUMPS SOUTH AFRICA (PTY) LTD**
Twenty One industrial Estate,
16 Purlin Street, Unit B, Warehouse 4
Olifantsfontein -1666 - South Africa
info.sa@dwtgroup.com
Tel. +27 12 361 3997

 **DAB PUMPS BV**
"tHofveld 6 C1
1702 Groot Bijgaarden - Belgium
info.belgium@dwtgroup.com
Tel. +32 2 4668353

 **DAB PUMPS HUNGARY KFT.**
H-8800
Nagykanizsa, Buda Ernő u.5
Hungary
Tel. +36 93501700

 **DAB PUMPS (QINGDAO) CO. LTD.**
No.40 Kaituo Road, Qingdao Economic & Technological
Development Zone
Qingdao City, Shandong Province - China
PC: 266500
sales.cn@dwtgroup.com
Tel. +86 400 186 8280
Fax +86 53286812210

 **DAB PUMPS B.V.**
Albert Einsteinweg, 4
5151 DL Drunen - Nederland
info.netherlands@dwtgroup.com
Tel. +31 416 387280
Fax +31 416 387299

 **DAB PUMPS POLAND Sp. z o.o.**
Ul. Janka Muzykanta 60
02-188 Warszawa - Poland
polska@dabpumps.com.pl

 **DAB PUMPS DE MÉXICO, S.A. DE C.V.**
Av Amsterdam 101 Local 4
Col. Hipódromo Condessa,
Del. Cuauhtémoc CP 06170
Ciudad de México
Tel. +52 55 6719 0493

 **OOO DAB PUMPS**
Novgorodskaya str. 1, block G
office 308, 127247, Moscow - Russia
info.russia@dwtgroup.com
Tel. +7 495 122 0035
Fax +7 495 122 0036

 **DAB PUMPS OCEANIA PTY LTD**
426 South Gippsland Hwy,
Dandenong South VIC 3175 - Australia
info.oceania@dwtgroup.com
Tel. +61 1300 373 677

 **DAB PUMPS GMBH**
Am Nordpark 3
D - 41069 Mönchengladbach - Germany
info.germany@dwtgroup.com
Tel. +49 2161 47388-0
Fax +49 2161 47388-36

 **DAB PUMPS INC.**
3226 Benchmark Drive
Ladson, SC 29456 - USA
info.usa@dwtgroup.com
Tel. 1- 843-797-5002
Fax 1-843-797-3366

 **PT DAB PUMPS INDONESIA**
Satrio Tower lantai 26
unit C-D, Jl. Prof. Dr. Satrio Kav. C4,
Kel. Kuningan Timur, Kec. Setiabudi, Kota Adm.
Jakarta Selatan, Prov. DKI Jakarta. - Indonesia
Tel. +62 2129222850